

FINE AND RARE WINES
MELINA & NK YONG'S CELLAR

佳士得名釀

Hong Kong 8-9 September 2017 | 香港 2017年9月8-9日



CHRISTIE'S 佳士得

INTERNATIONAL WINE DEPARTMENT & AUCTION CALENDAR

GLOBAL MANAGING DIRECTOR, LUXURY

Aline Sylla-Walbaum
Tel: +44 (0)20 7389 2554

HEAD OF DEPARTMENT/ HEAD OF SALE

ASIA

Simon Tam
Tel: +852 2978 6765

CONTINENTAL EUROPE

Edwin Vos
Tel: +31(0)20 575 5208

LONDON

Chris Munro
Tel: +44 (0)20 7752 3140

NEW YORK

Noah May
Tel: +1 212 636 2264

SENIOR CONSULTANT

Michael Broadbent M.W.
Tel: +44 (0)20 7752 3302

CONSULTANT

Carolyn Holmes
Tel: +44 (0)20 7752 3302
David Elswood
Tel: +44 (0)20 7752 3366

WORLDWIDE

AMSTERDAM

Edwin Vos
Tel: +31 (0)20 575 5208

BORDEAUX

Bill Blatch
Tel: +33 (0)777 965 565

GENEVA

Edwin Vos
Agathe de Saint Céran
Tel: +41 (0)22 319 1760

HONG KONG

Simon Tam
Fai Lo
Tiffany Po
Tel: +852 2978 6761

LONDON

Tim Triptree
Charles Foley
Tel: +44 (0)20 7752 3302

LOS ANGELES

Scott Torrence
Tel: +1 310 385 2625

NEW YORK

Noah May
Richard Young
Layla Khabiri
Scott Torrence
Tel: +1 212 636 2270

PARIS

Edwin Vos
Agathe de Saint Céran
Tel: + 33 (0)1 40 76 83 68

BUSINESS MANAGERS

FRANCE / GENEVA

Marie Faiola
Tel: +33 (0)1 40 76 86 10

HONG KONG

Cindy Tse
Tel: +852 2978 6759

LONDON

Laure Camboulives
Tel: +44 (0)20 7752 3252
Saara Thomas
(Head of Sale Management)
Tel: +44 (0)20 7389 2383

NEW YORK

Devon Elovitz
(Head of Sale Management)
Tel: +1 212 641 5776

18/07/17

AUCTION CALENDAR 2017

To include your property in these sales please consign ten weeks before the sale date. Contact the specialists or representative office for further information.

8 - 9 SEPTEMBER

FINE AND RARE WINES:
MELINA & NK YONG'S CELLAR
HONG KONG

9 SEPTEMBER

FINE AND RARE WINES:
ESTEEMED CONNOISSEUR
MR YAP CHEE MENG'S
PRIVATE COLLECTION PART II
HONG KONG

12 - 26 SEPTEMBER

WINE ONLINE/NYC

21 SEPTEMBER

FINE & RARE WINES
LONDON, KING STREET

26 SEPTEMBER - 10 OCTOBER
EXCEPTIONAL WINE ONLINE/NYC

28 SEPTEMBER - 12 OCTOBER
WINE ONLINE/HGK

12 NOVEMBER
FINEST & RAREST WINES
GENEVA

19 NOVEMBER
HOSPICE DE BEAUNE WINE
PARIS

24 & 25 NOVEMBER
FINE & RARE WINES
HONG KONG

28 NOVEMBER - 12 DECEMBER
WINE ONLINE/LDN

7 DECEMBER
FINE & RARE WINES
LONDON, KING STREET

8 - 9 DECEMBER
FINEST & RAREST WINES & SPIRITS
NEW YORK

SERVICES · 服務

WRITTEN AND TELEPHONE BIDS & CHRISTIE'S LIVE

書面和電話競投及佳士得實時競投服務

Tel 電話：+852 2978 9910

Email 電郵：bidsasia@christies.com

PADDLE REGISTRATION

競投牌登記

Tel 電話：+852 2760 1766

Email 電郵：registrationasia@christies.com

CATALOGUES ONLINE 網上拍賣目錄

Lotfinder®

Internet 網站：www.christies.com

CLIENT SERVICES 客戶服務

Tel 電話：+852 2760 1766

Email 電郵：infoasia@christies.com

POST-SALE SERVICES 售後服務

Tel 電話：+852 2760 1766

Email 電郵：postsaleasia@christies.com

ENQUIRIES · 查詢

HK 香港：+852 2760 1766

UK 英國：+44 (0)20 7627 2707

US 美國：+1 212 703 8080

Internet 網站：www.christies.com

We may convert and display in our catalogues the HK\$ **estimates** in US\$. This is for the convenience of our clients only and is not binding in any way. The rate of exchange is fixed at the latest practical date prior to the printing of the catalogue and may change by the time of the sale.

我們可將港元**估價**轉換成美元並於目錄中顯示。這僅為方便我們的客戶而不具有任何法律約束力。該貨幣兌換率是根據最貼近日錄付印時的兌換率設定，所以可能與拍賣當日兌換率有差別。

FINE AND RARE WINES: MELINA & NK YONG'S CELLAR 佳士得名釀

FRIDAY-SATURDAY 8-9 SEPTEMBER 2017
2017年9月8-9日(星期五至六)

AUCTION · 拍賣

Session I

Friday 8 September · 9月8日(星期五)

5.00pm (Lots 1-267) · 下午5.00(拍賣品編號1-267)

Session II

Saturday 9 September · 9月9日(星期六)

11.00am (Lots 268-476) · 上午11.00(拍賣品編號268-476)

Location: The James Christie Room, 22nd Floor, Alexandra House,
18 Chater Road, Central, Hong Kong

地點：香港中環遮打道18號歷山大廈22樓佳士得藝廊

Tel 電話：+852 2760 1766 · Fax 傳真：+852 2760 1767

AUCTION CODE AND NUMBER · 拍賣名稱及編號

In sending Written and Telephone bids or making enquiries, this sale should be referred to as **SING-14719**

在遞交書面和電話競投表格或查詢拍賣詳情時，請註明拍賣名稱及編號為 **SING-14719**。

CONDITIONS OF SALE · BUYING AT CHRISTIE'S

業務規定 · 買家須知

This auction is subject to Important Notices and Explanation of Cataloguing Practice, Conditions of Sale · Buying at Christie's and reserves of the lots.

此次拍賣受限於重要通知及目錄編列方法之說明、業務規定 · 買方須知及拍品底價。

SALE CO-ORDINATOR · 拍賣統籌

Joyce Cheung

Tel 電話：+852 2978 6763

EMAIL · 電郵

For general enquiries about this auction, emails should be addressed to the Sale Co-ordinator(s) at wineauction@christies.com

如對此拍賣有任何查詢，可與佳士得拍賣統籌聯絡。

電郵地址：wineauction@christies.com

AUCTIONEERS · 拍賣官

David Elswood

Simon Tam

CHRISTIE'S LIVE
Bid live in Christie's salerooms worldwide

christies.com

CHRISTIE'S 佳士得

INTERNATIONAL WINE DEPARTMENT

ASIA TEAM



Simon Tam



Fai Lo



Tiffany Po



Cindy Tse

SENIOR INTERNATIONAL TEAM



Chris Munro



Edwin Vos

INTERNATIONAL CONSULTANTS



Michael Broadbent M.W.



Bill Blatch



David Elswood

FINE AND RARE WINES: MELINA & NK YONG'S CELLAR

佳士得名釀

SESSION I

FRIDAY 8 SEPTEMBER 2017

5.00pm

Lots 1-267

Sale 14719

9月8日(星期五)

下午五時正

(拍品 1 至 267)

編號 14719

SESSION II

SATURDAY 9 SEPTEMBER 2017

11.00am

Lots 268-476

Sale 14719

9月9日(星期六)

上午十一時正

(拍品 268 至 476)

編號 14719

The James Christie Room, 22nd Floor, Alexandra House,
18 Chater Road, Central, Hong Kong
香港中環遮打道 18 號歷山大廈 22 樓佳士得藝廊

Please note that parcel bidding will be offered throughout Sale 14719.

請注意，本場拍賣(編號 14719)部份拍品將以組合形式推出。成功投得每個組合第一款拍品的買家，可選擇以同一價格購買餘下所有或部份拍品。

Fine And Rare Wines: Melina & NK Yong's Cellar

"Welcome to Christie's Fine & Rare Wines Auction.

Singapore based, Dr NK and Melina Yong need no introduction in the world of wine. I first met the couple in 1993 and was immediately struck by their passion for yummy food and wine. They share generously but always in a no nonsense and humble manner. The pleasure of their guests was always the number one priority.

While the Prue Leith- trained Melina master-minded and presided over numerous memorable events and charity functions, NK never gave up the opportunity to educate the younger generation.

I fondly recall on one occasion, NK presented to myself and two visiting MWs a red wine to taste blind. We were convinced that it was a Classified Bordeaux with bottle age. But it was of course, a South African Cabernet. There have been many more eye-opening tastings with NK since."

It gives me incredible pleasure and privilege to present Melina and NK's Cellar.

All the wines in this sale come directly from the Chateaux, Domaines, Bodegas, Tenutas, Weinguts, Quintas of the finest producers and fable names. Many of whom are Melina and NK's lifelong friends.

An important noteworthy point is Melina and NK's Cellar temperature is a constant 10 degrees C. Where most professional cellarage hover at around 12-14 degrees C.

"Yes our cellar temperature is a constant 10 degrees. I advocate 10 degrees for our climate because our climate is so warm — 32 degrees — that the bottles warm up very quickly once brought out to the dining room. I have a horror of drinking my wine, red and white, at 28 degrees or more. I find to my dismay that not only in Singapore, but also in Europe, especially in the restaurants that wines are served too warm. An insult to the wine growers. 'Also, at this temperature, the wines may take longer to develop (which I do not mind as I am only 90 years old!) and they age better.' chuckled NK.

Good luck with your bids!

Simon Tam

Head of Wine, Asia

佳士得名釀

「歡迎參加佳士得名釀拍賣。來自新加坡的Dr NK Yong和Melina是品酒界享負盛名的人物，我與二人相識於1993年，他們對美酒佳釀的熱忱令我深感佩服，夫婦二人從不吝於分享珍藏，知識淵博而且作風謙遜，摯誠與客人共享美好時刻。

Melina曾跟隨餐飲大師Prue Leith學藝，並曾策劃及主理多場難忘盛事及慈善活動，而Dr Yong則積極扶掖後輩，培育年輕人才。

記得有一次，Dr Yong帶來一瓶紅酒，讓我與兩位作客的葡萄酒大師進行盲品，我們深信那是波爾多頂級酒莊的瓶陳佳釀，後來卻得知原來是南非陳釀。自此我不時跟隨Dr Yong品酒，眼界大開。」

能夠為大家帶來Dr Yong和Melina的窖藏珍釀，實在深感興奮和榮幸。

是次拍賣的所有佳釀皆由頂級葡萄園及名莊直送，當中不少與Dr Yong和Melina相識多年。值得留意的是Dr Yong和Melina的酒窖維持在攝氏10度，有別於專業酒窖約攝氏12度至14度的溫度。

Dr Yong笑言：「是的，我們將酒窖溫度維持在攝氏10度，因為新加坡的氣溫高達32度，葡萄酒離開酒窖後便會迅速變暖，所以我才採取這種做法。我曾喝過28度以上的葡萄酒，感覺實在糟糕。令我詫異的是，不但在新加坡，在歐洲的餐廳也會奉上過暖的葡萄酒，實在是對釀酒者的一大侮辱。另外，在此溫度下，葡萄酒需要更長時間才能成熟（我才90歲，不介意多等一會），而陳化效果亦更佳。」

祝大家好運，成功投得心頭好！

譚業明

佳士得亞洲區名酒部主管

FRIDAY 8 SEPTEMBER · 5.00PM

SESSION I: Lots 1-267

FINE AND RARE WINES: MELINA & NK YONG'S CELLAR

佳士得名釀

Château Cos d'Estournel 2004
Saint-Estéphe, 2ème cru classé
In original wooden case
 1 12 bottles per lot HK\$7,500-11,000

Château Cos d'Estournel 2005
Saint-Estéphe, 2ème cru classé
In original wooden case
 2 12 bottles per lot HK\$12,000-18,000

Château Cos d'Estournel 2006
Saint-Estéphe, 2ème cru classé
In original wooden case
 3 12 bottles per lot HK\$7,000-11,000

Château Cos d'Estournel 2007
Saint-Estéphe, 2ème cru classé
Lot 4: Twelve in original wooden case
Lot 5: In original wooden cases
 4 24 bottles per lot HK\$11,000-17,000
 5 24 "

Château Cos d'Estournel 2008
Saint-Estéphe, 2ème cru classé
In original wooden cases
 6 24 bottles per lot HK\$15,000-22,000

Château Cos d'Estournel 2009
Saint-Estéphe, 2ème cru classé
In original wooden case
 7 12 bottles per lot HK\$18,000-26,000

Château Cos d'Estournel 2010
Saint-Estéphe, 2ème cru classé
In three-magnum original wooden cases
 8 9 magnums per lot HK\$20,000-30,000

Château Cos d'Estournel 2010
Saint-Estéphe, 2ème cru classé
In six-bottle original wooden cases
 9 12 bottles per lot HK\$14,000-20,000

Château Cos d'Estournel 2010
Saint-Estéphe, 2ème cru classé
In original wooden cases
 10 18 bottles per lot HK\$20,000-30,000

Mixed Formats of Château Cos d'Estournel 2011
2011
In original wooden case magnums (3)
2011
In six-bottle original wooden cases (18)
 11 3 magnums and 18 bottles per lot HK\$11,000-17,000

Mixed 2006 & 2008 Les Pagodes de Cos
2006 (12)
2008 (12)
In original wooden cases
 12 24 bottles per lot HK\$5,500-8,500



Lot 3

	Mixed 2009 & 2010 Les Pagodes de Cos	
	2009	(12)
	2010	(12)
	<i>In original wooden cases</i>	
13	24 bottles	per lot HK\$8,000-13,000
	Mixed 2003 Château Montrose & La Dame de Montrose	
	Château Montrose 2003	(12)
	La Dame de Montrose 2003	(12)
	<i>In original wooden cases</i>	
14	24 bottles	per lot HK\$18,000-26,000
	Château Montrose 2005	
	<i>Saint-Estéphe, 2ème cru classé</i>	
	<i>In original wooden cases</i>	
15	24 bottles	per lot HK\$17,000-24,000
	Château Montrose 2010	
	<i>Saint-Estéphe, 2ème cru classé</i>	
	<i>In original wooden case</i>	
16	12 bottles	per lot HK\$14,000-20,000
	Château Calon-Séguir 2006	
	<i>Saint-Estéphe, 3ème cru classé</i>	
	<i>In original wooden case</i>	
17	12 bottles	per lot HK\$4,800-7,500

Château Lafite Rothschild

Château Lafite Rothschild, owned by the Rothschild family for five generations, was acquired by Baron James de Rothschild in 1868. The existence of Lafite as a medieval fief dates back to the 14th century; at the beginning of the 18th century Lafite's wine was already being sold in London, where it was a favourite of the Prime Minister, Robert Walpole. In France, Lafite soon became known as the "King's wine", after being introduced to the Court at Versailles by Maréchal Richelieu. The classification of the Grands Crus Classés, prepared on the occasion of the 1855 Universal Exhibition in Paris, officially ranked Château Lafite as the "Premier des Premiers".

The 112 hectare vineyard consists of three main areas: the slopes around the Château, the adjacent Carruades plateau to the west and a 4.5 hectare plot in the neighbouring commune of Saint Estéphe. The vines are planted in well-drained and well-exposed soil made up of fine, deep gravel, mixed with aeolian sand on a subsoil of tertiary limestone. The grape varieties are Cabernet Sauvignon (70%), Merlot (25%), Cabernet Franc (3%) and Petit Verdot (2%). The average age of the vines is 45 years for the Grand Vin; the oldest plot, "La Gravière", was planted in 1886.

拉菲酒莊

拉菲莊 1868 年由詹姆斯羅斯柴爾德男爵買下，至今已在家族中傳承五代。早在 14 世紀，拉菲莊就是中世紀的封地；18 世紀初，拉菲莊葡萄酒已經在倫敦有售，當時被譽為是首相羅伯特·沃波爾的至愛佳釀。在法國，自從黎塞留將拉菲莊引入凡爾賽宮宮廷，拉菲莊很快就成為「皇帝御用佳釀」。等級評定制於 1855 年巴黎世界博覽會中誕生，並將拉菲莊正式評定為「一等一」葡萄酒。

葡萄園佔地 112 公頃，由三個主要地區組成：酒莊附近的山坡，隔鄰向西面伸延的珍寶高地，以及鄰近聖艾斯岱夫地區一塊面積 4.5 公頃葡萄田。葡萄藤生長在容易疏水、陽光充足的土地上，土壤由第三系石灰岩基土混合風沙、深層精細砂礫土組成。葡萄品種為赤霞珠（70%）、梅洛（25%）、品麗珠（3%）、小維多（2%）。正牌的葡萄藤平均 45 歲，當中最老的一株「La Gravière」，於 1886 年種下。

Château Lafite-Rothschild 1961

Pauillac, 1er cru classé

Slightly damaged capsules. One badly damaged label, two slightly damaged with one handwriting. US import slip labels. Levels one top-shoulder, one upper-shoulder, two low-shoulder

18 4 bottles per lot HK\$24,000-42,000

1986 BORDEAUX VINTAGE REPORT

I must confess, my first, second and most recent impressions of this vintage have varied. At first I didn't know quite what to make of it. Then, after the 1988s came along I saw a certain similarity, linking the '86s and '88s as firm, relatively slow off the mark. But can the most prolific crop since World War Two, 15% bigger than 1985, produce wines of real quality? The '85s managed it, but the weather conditions were slightly different. In 1986 bud break was delayed, though the weather improved and the flowering was successful. The summer was hot and dry until the latter part of September when, after a useful sprinkling of rain, there was a violent storm which dumped 10cm of rain on the city of Bordeaux and its immediate surroundings. The harvest began at the very end of September and continued into October in glorious weather. Having read through a large number of my notes, my impression of the vintage has become more clarified, and I think I can answer the question posed above.

On the whole, 1986 produced hard, tannic wines which at best, given time, might – just might – turn out well. But I would not bank on it, except for Mouton and just one or two others. They are of course good 'food wines' and are unlikely to go 'over the hill' without plenty of notice. Michael Broadbent M.W.

1986 年波爾多年份報告

我承認對這個年份的初次、第二次和最近的印象也不同。最初我不知道該怎樣評價它，但在嚐過 1988 年份後，我發現兩者相似的地方，兩者也單寧厚實，較遲展現特質。然而，二戰以來最豐收的一年（比 1985 年多 15%）能釀造真正的佳釀嗎？1985 年可以，但當時的天氣略為不同。1986 年萌芽期較遲，但其後天氣轉佳，開花順利。夏季不熱不乾，一直維持至 9 月下旬，但灑下幾場及時雨後風暴來襲，波爾多及鄰近地區降雨量達 10 厘米。9 月底開始收割，一直延續至風和日麗的 10 月。翻閱我的酒評後，我對此年份的印象更加清晰，相信可解答上文提出的問題。

整體而言，1986 年酒質較硬、單寧偏重，假以時日可能（只是可能）有機會成為佳釀，但除了木桐莊和一、兩家酒莊外，我指望不大。1986 年當然是上好「餐酒」，而且突然過度陳年的機會不大。葡萄酒大師米高·布羅德班

Château Lafite-Rothschild 1986

Pauillac, 1er cru classé

Two damaged capsules. Two slightly damaged labels. Levels base of neck

19 6 bottles per lot HK\$38,000-55,000

Château Lafite-Rothschild 1989
Pauillac, 1er cru classé
Five Singaporean import slip labels. Levels into neck
 20 12 bottles *per lot* HK\$45,000-70,000

Château Lafite-Rothschild 2000
Pauillac, 1er cru classé
In original wooden case
 21 12 bottles *per lot* HK\$110,000-160,000

Château Lafite-Rothschild 2001
Pauillac, 1er cru classé
In original wooden cases
 22 12 bottles *per lot* HK\$48,000-70,000
 23 12 "

Château Lafite-Rothschild 2002
Pauillac, 1er cru classé
In banded original wooden cases
 24 12 bottles *per lot* HK\$45,000-65,000
 25 12 "
 26 12 "

Château Lafite-Rothschild 2003
Pauillac, 1er cru classé
In banded original wooden case
 27 6 magnums *per lot* HK\$60,000-90,000

Château Lafite-Rothschild 2003
Pauillac, 1er cru classé
In original wooden case
 28 12 bottles *per lot* HK\$70,000-100,000

Château Lafite-Rothschild 2004
Pauillac, 1er cru classé
In banded original wooden cases
 29 12 bottles *per lot* HK\$45,000-70,000
 30 12 "
 31 12 "

Château Lafite-Rothschild 2005
Pauillac, 1er cru classé
In banded original wooden cases
 32 12 bottles *per lot* HK\$60,000-90,000
 33 12 "

Château Lafite-Rothschild 2006
Pauillac, 1er cru classé
In banded original wooden cases
 34 12 bottles *per lot* HK\$48,000-70,000
 35 12 "
 36 12 "
 37 12 "
 38 12 "

Château Lafite-Rothschild 2007
Pauillac, 1er cru classé
Lot 39: In banded six-bottle original wooden cases
Lot 40: In banded original wooden case
 39 12 bottles *per lot* HK\$48,000-70,000
 40 12 "

Château Lafite-Rothschild 2008
Pauillac, 1er cru classé
In banded original wooden case
 41 6 bottles *per lot* HK\$24,000-38,000



Lot 16

Château Lafite-Rothschild 2008
Pauillac, 1er cru classé
In banded original wooden cases

42 12 bottles *per lot* HK\$48,000-75,000
 43 12 "

Château Lafite-Rothschild 2009
Pauillac, 1er cru classé
In banded original wooden case

44 6 bottles *per lot* HK\$28,000-40,000

Château Lafite-Rothschild 2009
Pauillac, 1er cru classé
In banded original wooden case

45 12 bottles *per lot* HK\$55,000-80,000

Château Lafite-Rothschild 2010
Pauillac, 1er cru classé
In banded three-magnum original wooden cases

46 6 magnums *per lot* HK\$55,000-85,000

Château Lafite-Rothschild 2010
Pauillac, 1er cru classé
In banded six-bottle original wooden cases

47 12 bottles *per lot* HK\$55,000-85,000

Château Lafite-Rothschild 2011
Pauillac, 1er cru classé
Six in banded six-bottle original wooden case. Three in banded
three-bottle original wooden case

48 9 bottles *per lot* HK\$24,000-38,000

Carruades de Lafite-Rothschild 2002
Pauillac
In original wooden case

49 6 magnums *per lot* HK\$15,000-22,000

Carruades de Lafite-Rothschild 2003
Pauillac
In banded original wooden case

50 12 bottles *per lot* HK\$15,000-22,000

Carruades de Lafite-Rothschild 2004
Pauillac

51 8 bottles *per lot* HK\$10,000-15,000

Carruades de Lafite-Rothschild 2004
Pauillac
In banded original wooden cases

52 12 bottles *per lot* HK\$15,000-22,000
 53 12 "
 54 12 "

Carruades de Lafite-Rothschild 2005
Pauillac
In banded original wooden case

55 12 bottles *per lot* HK\$18,000-26,000

Carruades de Lafite-Rothschild 2006
Pauillac
In banded original wooden cases

56 24 bottles *per lot* HK\$32,000-48,000

Carruades de Lafite-Rothschild 2007
Pauillac
In banded original wooden case

57 12 bottles *per lot* HK\$15,000-22,000

Carruades de Lafite-Rothschild 2008
Pauillac
In banded original wooden case

58 12 bottles *per lot* HK\$16,000-24,000



Lots 44 & 45

Château Latour

Château Latour is situated in the heart of the Médoc wine region, about 50 km north-west of Bordeaux, where the legend of the vineyards of Bordeaux began. The Château's prime terroir, l'Enclos, overlooks the estuary of the Gironde river which, over the centuries, has given the vineyard its geological complexity and, on a daily basis, ensures a mild climate. Most of Château Latour's vines are planted on gravelly hilltops that stand 12 to 16 meters above the Gironde estuary. The fortunate combination of the Gironde, layers of gravel on the surface and clay subsoil gives Château Latour's terroir advantages that few other vineyards can claim. The vineyard currently consists of 90 hectares in production; it is the grapes from the 47 hectares that surround the Château, known as "l'Enclos" that may potentially be used in the production of the Grand Vin. The estate is planted with about 80% of Cabernet Sauvignon, 18% of Merlot and 2% of Cabernet Franc and Petit Verdot.

In the years since 1993, under the leadership of François Pinault and his family, the estate's owners, significant changes have been made with a view to maintaining Château Latour's pursuit of excellence in the wines that it produces.

In 1998, Frédéric Engerer, who joined the estate early in 1995, was appointed President. Major works started in November 1999 and continued until September 2003. A total renovation of the winery, vat room, wine making facilities and storage areas enabled even greater precision in the production of the wines. A new technical team was also created.

The 90 hectares of the estate are locally managed by Frédéric Engerer and his team. Today, the men and women working at Château Latour in the vineyard and in the cellar are motivated by a search of perfection. Numerous experiments are continuously being carried out in order to judge the suitability of new procedures. This might for example involve biodynamic methods or new traceability systems, their quest is always for precision, quality and awareness of new issues.

拉圖酒莊

酒莊位於波爾多西北面 50 公里的梅鐸產區中央，是波爾多葡萄酒傳奇的發源地。酒莊的風土主要源自朗克洛葡萄酒園，眺望吉倫特河口，數百年以來形成複雜的地質結構，而氣候則溫和宜人。拉圖酒莊大部份葡萄樹均種植在吉倫特河口上方 12 至 16 米的碎石山頂上，毗鄰吉倫特河的地理位置，加上泥土表面的礫石層及黏土底土，造就與眾不同的風土特色。葡萄園目前有 90 公頃種植葡萄樹，其中圍繞酒莊的朗克洛區園地佔地 47 公頃，此範圍種植的葡萄可釀製特級葡萄酒。葡萄園內約八成為赤霞珠，18% 為美樂葡萄，其餘 2% 為品麗珠及小維多葡萄。

弗朗索·皮諾在 1993 年成為莊主後，為保持葡萄酒的出眾品質，他於經營上作出重大的變革。恩傑爾在 1995 年初加入酒莊，並於 1998 年擔任總裁。

在 1999 年 11 月至 2003 年 9 月期間，酒莊展開多項大型工程，包括全面翻新釀酒廠、酒桶貯存室、釀酒設備及貯酒庫，務求令釀酒過程更加精準。另外，酒莊亦設立新的技術團隊。

拉圖酒莊佔地 90 公頃，由弗雷德里克·恩傑爾及其團隊管理。時至今日，無論是葡萄園還是酒窖的員工，皆致力精益求精，力臻完美。為測試新釀酒程序的成效，酒莊不斷進行實驗，例如採用生物動力方法或新穎的溯源系統，務求品質優良精準，並及時解決各種問題。

Château Latour 1961

Pauillac, 1er cru classé

One damaged capsule. Slightly wrinkled labels. John Harvey slip labels. Levels mid-shoulder

59 4 bottles *per lot* HK\$30,000-65,000

Château Latour 1970

Pauillac, 1er cru classé

Damaged capsules. Three stained labels, two damaged. Levels two top-shoulder, three upper-shoulder

60 5 bottles *per lot* HK\$16,000-24,000

Château Latour 1982

Pauillac, 1er cru classé

Levels base of neck or better

61 6 bottles *per lot* HK\$60,000-90,000

Château Latour 1986

Pauillac, 1er cru classé

Two slightly corroded capsules. Levels base of neck or better

62 6 bottles *per lot* HK\$16,000-22,000

Château Latour 1989

Pauillac, 1er cru classé

One slightly damaged label. Levels base of neck

63 4 bottles *per lot* HK\$10,000-16,000

1990 BORDEAUX VINTAGE REPORT

An excellent vintage with similar attributes to the '89 but certainly not an identical twin. First, the growing conditions. January to March unusually warm and sunny, up to 25 degrees C on 24 February, advancing vegetation. Beneficial rain in April followed by a very hot, dry and sunny May. The flowering was uneven and prolonged, satisfactory for the Merlots, less so for Cabernet Sauvignon. July was excessively hot, up to just short of 39 degrees C on the 21st. This heat had a reverse effect, hindering maturation by impeding the rising of the sap. August was warm and dry. Unlike 1989 this did not deter the ripening, as a well-timed beneficial sprinkling of rain in September enabled the grapes to be harvested from around mid-month. In general, the Merlots were in remarkable condition with some of the highest levels of sugar ever recorded. The later ripening Cabernet Sauvignon grapes were small and thick, with a concentration of juice and colouring matter. Michael Broadbent M.W.

1990 年波爾多年份報告

極優秀的年份，不少特質也與 1989 年相似，但當然並非一模一樣。首先是生長條件，1 至 3 月異常溫暖，陽光普照，2 月 24 日氣溫更高達攝氏 25 度，加快葡萄藤生長。4 月雨下得及時，隨之為極度炎熱乾燥和晴朗的 5 月。開花期不平均和延長，適合梅洛葡萄生長，對赤霞珠則不太理想。7 月奇熱無比，7 月 21 日高溫接近攝氏 39 度，酷熱天氣令葡萄難以輸送汁液，窒礙成熟進度。8 月溫暖而乾燥，幸好未如 1989 年般阻礙葡萄成熟，因 9 月的一場及時雨讓酒莊能在月中開始收割葡萄。整體而言，梅洛的品質出眾，部分含有的糖份更創新高。較遲收割的赤霞珠果實小而肉厚，汁濃而色澤飽滿。葡萄酒大師米高·布羅德班

Mixed 1990 & 1992 Château Latour

1990

Stained label. Level upper-shoulder

(1)

1992

Levels base of neck

(2)

64 3 bottles *per lot* HK\$9,500-14,000

Château Latour 2004

Pauillac, 1er cru classé

In original wooden case

65 12 bottles *per lot* HK\$32,000-48,000

Château Latour 2005

Pauillac, 1er cru classé

In original wooden case

66 12 bottles *per lot* HK\$55,000-85,000

67 12 "

Château Latour 2006

Pauillac, 1er cru classé

In banded original wooden case

68 12 bottles *per lot* HK\$32,000-48,000

Château Latour 2006
Pauillac, 1er cru classé
In original wooden cases
 69 18 bottles per lot HK\$48,000-70,000

Château Latour 2007
Pauillac, 1er cru classé
In banded original wooden cases
 70 12 bottles per lot HK\$32,000-48,000
 71 12 "

Château Latour 2008
Pauillac, 1er cru classé
In banded original wooden cases
 72 12 bottles per lot HK\$35,000-50,000
 73 12 "

Château Latour 2009
Pauillac, 1er cru classé
In banded original wooden case
 74 6 bottles per lot HK\$35,000-55,000

Château Latour 2010
Pauillac, 1er cru classé
Six in banded six-bottle original wooden case. Three in three-bottle original wooden case
 75 9 bottles per lot HK\$50,000-80,000

Château Latour 2011
Pauillac, 1er cru classé
Twelve in original wooden case. Three in three-bottle original wooden case
 76 15 bottles per lot HK\$42,000-65,000

2004 BORDEAUX VINTAGE REPORT

A useful, agreeable, underrated and relatively reasonably priced vintage; these are wines for future drinking not investment. Careful selection is needed as by no means all the properties could afford the vital and expensive green-pruning and crop selection to avoid unripe grapes with raw tannins.

The weather was conducive; the flowering taking place in perfect conditions, even and speedy, the absence of coulure and millerandage ensuring a large crop and, all being well, an early harvest. The summer was warm, with refreshing showers. However August was very wet and temperature levels declined. A big crop of large bunches made full ripening and dilution a problem. Properties on the Left and Right Banks has similar successes - and failures, mainly due to the affordability of severe crop-thinning and selection. One thing is common: high tannin levels, the best soft, the last successful harsh. Michael Broadbent M.W.



Lot 80

2004 年波爾多年份報告

此年份的出品味道宜人，價格相對合理，但被低估。因此，葡萄酒適合日後飲用，但並非投資之選。購入時需要小心挑選，謹記雖然摘去未成熟果實及篩選收成是關鍵的步驟，能避免來自未成熟果實的劣質單寧，但並非所有莊園也能負擔高昂的成本。

天氣有利葡萄生長，開花期在完美天氣下進行，均衡而迅速，沒有出現落果和果實大小不一的問題，保證收成豐盛，如無意外可提早收割。夏季溫暖，間中有雨，但 8 月非常潮濕，氣溫下降。大串葡萄豐收令果實未能完全成熟，攤薄養份。由於減少結果和篩選果實的成本問題，左右兩岸莊園的成敗情況也相若。但兩岸的共通之處是葡萄單寧含量高，其中上品的單寧柔順，下品則粗糙。葡萄酒大師米高·布羅德班

Les Forts de Latour 2004

Pauillac

In original wooden cases

77 24 bottles *per lot* HK\$22,000-32,000

Les Forts de Latour 2005

Pauillac

In original wooden cases

78 24 bottles *per lot* HK\$26,000-38,000

Les Forts de Latour 2008

Pauillac

In original wooden case

79 12 bottles *per lot* HK\$12,000-18,000

Mixed Formats of Les Forts de Latour 2010

2010

magnums (3)

2010

(6)

In original wooden cases

80 3 magnums and 6 bottles *per lot* HK\$13,000-19,000

Les Forts de Latour 2011

Pauillac

In original wooden case

81 12 bottles *per lot* HK\$10,000-15,000

Château Mouton Rothschild

Château Mouton Rothschild, a Premier Grand Cru Classé, now belongs to Camille Sereys de Rothschild, Philippe Sereys de Rothschild and Julien de Beaumarchais de Rothschild, the three children of Baroness Philippine de Rothschild and grandchildren of the legendary Baron Philippe. The estate comprises 83 hectares of vines in Pauillac, planted with Cabernet Sauvignon (81%), Merlot (15%), Cabernet Franc (3%) and Petit Verdot (1%), and boasts an exceptional terroir, both for the quality of its soil and its exposure to sunlight. Combining respect for tradition with the latest technology, meticulous care and attention are given from grape to bottle: hand picking, manual and optical sorting, fermentation vats with transparent staves and maturing in new oak barrels. Château Mouton Rothschild's history can be summarized in a few key dates:

In 1853, Baron Nathaniel de Rothschild, from the English branch of the family, acquired Château Brane-Mouton, which he renamed Château Mouton Rothschild.

In 1922, his great-grandson, Baron Philippe (1902-1988), took the future of the estate into his own hands.

In 1924, he was the first to introduce château bottling.

In 1926, he built the famous Grand Chai, a majestic 100-metre barrel hall.

1945, the Victory year that concluded the Second World War, heralded the start of an exciting collection of artworks created each year by famous painters for the Mouton label.

1962 saw the inauguration of the Museum of Wine in Art, a collection of precious objects devoted to the vine and wine spanning three millennia.

In 1988, Baroness Philippine (1933-2014) succeeded her father at the head of the estate, becoming in her turn the guarantor of the quality of this illustrious wine. In 1991, she created Aile d'Argent, a white wine made from grapes grown on a few hectares of vines on the Mouton estate planted with Sauvignon Blanc (57%), Sémillon (42%) and Muscadelle (1%).

In 1993, for the first time, Mouton also began to produce a Second Wine, le Petit Mouton de Mouton Rothschild.

In 2013, Baroness Philippine crowned the renovation of Mouton with the inauguration of a new vat room and an exhibition space for "Paintings for the Labels", a permanent display of the original artworks that illustrate the Mouton vintages.

In 2014, Philippe Sereys de Rothschild succeeded his mother as Chairman of the Supervisory Board of Baron Philippe de Rothschild S.A. He had been Vice Chairman since 2006.

木桐酒莊

一級酒莊木桐莊現為菲利普男爵的孫兒，亦即菲利浦女男爵的三名孩子卡米爾·塞雷·羅斯柴爾德、菲利浦·塞雷·羅斯柴爾德和朱利安·波瑪柴·羅斯柴爾德所有。

位於波亞克的葡萄園佔地 83 公頃，種有赤霞珠（81%）、梅洛（15%）、品麗珠（3%）和小維鐸（1%），風土卓越，土壤優質，陽光充沛。酒莊一方面秉承悠久傳統，另一方面則採用最新技術，從種植葡萄到入瓶均一絲不苟，過程包括人手採摘、親手和目測分類、使用配備透明觀察面的發酵桶、在新橡木桶內陳釀等。木桐莊的歷史包含數個重要日期。

1853 年，來自英國家族的內森·羅斯柴爾德男爵收購布朗·木桐莊，並更名為羅斯柴爾德木桐莊。

1922 年，他的曾孫菲利浦男爵（1902-1988）接掌酒莊。

1924 年，他率先推行「酒莊內裝瓶」。

1926 年，他建立了長達 100 米的著名「大酒窖」。

1945 年，二戰結束，象徵勝利的一年，首度邀請知名畫家繪製木桐酒標，自此更成為傳統，匯聚無數藝術傑作。

1962 年，「葡萄酒藝術博物館」揭幕，收藏三千年來與葡萄種植和葡萄酒有關的珍貴展品。

1988 年，菲利浦女男爵（1933-2014）繼承其父的酒莊，致力保持名釀品質。

1991 年，她創作出「銀翼」，此白酒產自一塊面積數公頃的木桐莊葡萄園，栽種品種包括賽美蓉（57%）、蘇維翁（42%）和密斯卡岱（1%）。

1993 年，木桐莊首次生產副牌酒「小木桐」。

2013 年，木桐莊在菲利浦女男爵的帶領下再創新猷，啟用全新發酵車間，「藝術與酒標」大廳亦正式揭幕，永久展示與木桐莊年份有關的原創藝術作品。

2014 年，菲利浦·塞雷·羅斯柴爾德接替其母出任菲利浦·羅斯柴爾德男爵公司監事會主席。他自 2006 年起擔任該會的副主席。

Château Mouton-Rothschild 1953

Pauillac, 1er cru classé

Slightly damaged label. Level upper-shoulder

82 1 bottle *per lot* HK\$10,000-15,000

Château Mouton-Rothschild 1961

Pauillac, 1er cru classé

Damaged labels. Levels one top-shoulder, one mid-shoulder

83 2 bottles *per lot* HK\$17,000-30,000

	Château Mouton-Rothschild 1982 <i>Pauillac, 1er cru classé</i> <i>In original wooden case. Good appearance. Levels ten base of neck, one upper-shoulder, one mid-shoulder</i>	
84	12 bottles	<i>per lot</i> HK\$85,000-130,000
	Château Mouton-Rothschild 1986 <i>Pauillac, 1er cru classé</i> <i>One corroded capsule. Two slightly stained labels. Integrated US labels. Levels base of neck</i>	
85	6 bottles	<i>per lot</i> HK\$30,000-45,000
	Château Mouton-Rothschild 2003 <i>Pauillac, 1er cru classé</i> <i>In original wooden case</i>	
86	12 bottles	<i>per lot</i> HK\$35,000-55,000
	Château Mouton-Rothschild 2006 <i>Pauillac, 1er cru classé</i> <i>In banded original wooden cases</i>	
87	12 bottles	<i>per lot</i> HK\$35,000-55,000
88	12 "	
	Château Mouton-Rothschild 2007 <i>Pauillac, 1er cru classé</i> <i>In banded original wooden case</i>	
89	6 bottles	<i>per lot</i> HK\$15,000-22,000
	Château Mouton-Rothschild 2008 <i>Pauillac, 1er cru classé</i> <i>In original wooden cases</i>	
90	12 bottles	<i>per lot</i> HK\$32,000-50,000
	Château Mouton-Rothschild 2008 <i>Pauillac, 1er cru classé</i> <i>In original wooden cases</i>	
91	18 bottles	<i>per lot</i> HK\$50,000-75,000
	Château Mouton-Rothschild 2009 <i>Pauillac, 1er cru classé</i> <i>In original wooden case</i>	
92	6 magnums	<i>per lot</i> HK\$45,000-70,000
	Château Mouton-Rothschild 2009 <i>Pauillac, 1er cru classé</i> <i>In banded original wooden case</i>	
93	6 bottles	<i>per lot</i> HK\$22,000-35,000

	Château Mouton-Rothschild 2009 <i>Pauillac, 1er cru classé</i> <i>In banded original wooden case</i>	
94	12 bottles	<i>per lot</i> HK\$45,000-70,000
	Mixed Formats of Château Mouton-Rothschild 2010 2010 <i>In original wooden case</i>	magnums (3)
	2010 <i>In banded original wooden case</i>	(6)
95	3 magnums and 6 bottles	<i>per lot</i> HK\$45,000-70,000
	Mixed Formats of Château Mouton-Rothschild 2011 2011 <i>In original wooden case</i>	magnums (3)
	2011 <i>In banded original wooden case</i>	(6)
96	3 magnums and 6 bottles	<i>per lot</i> HK\$28,000-40,000
	Mixed 2005 & 2006 Château Pichon-Longueville, Baron 2005 2006	(12) (12)
	<i>In original wooden cases</i>	
97	24 bottles	<i>per lot</i> HK\$16,000-26,000
	Château Pichon-Longueville, Baron 2009 <i>Pauillac, 2ème cru classé</i> <i>In original wooden case</i>	
98	12 bottles	<i>per lot</i> HK\$9,500-14,000
	Château Pichon-Longueville, Lalande 1982 <i>Pauillac, 2ème cru classé</i> <i>One slightly damaged label. Levels into neck</i>	
99	6 bottles	<i>per lot</i> HK\$24,000-35,000
	Château Pichon-Longueville, Lalande 1986 <i>Pauillac, 2ème cru classé</i> <i>Three stained and three slightly stained labels. Levels base of neck</i>	
100	6 bottles	<i>per lot</i> HK\$7,500-11,000
	Mixed 2005 & 2006 Château Pichon-Longueville, Lalande 2005 2006	(12) (12)
	<i>In original wooden cases</i>	
101	24 bottles	<i>per lot</i> HK\$15,000-24,000
	Mixed 2007-2009 Château Pichon-Longueville, Lalande 2007 2008 2009	(12) (12) (12)
	<i>In original wooden cases</i>	
102	36 bottles	<i>per lot</i> HK\$24,000-35,000



CHON LONGUE
CHATEAU PICHON-LONGUEVILLE
LE BARON de PICHON-LONGUEVILLE
2006
CRU CLASSÉ EN 1855
PAUILLAC

LE CHATEAU
CHATEAU PICHON-LONGUEVILLE
LE BARON de PICHON-LONGUEVILLE
2005
CRU CLASSÉ EN 1855
PAUILLAC

CHATEAU PICHON
CHATEAU PICHON-LONGUEVILLE
2005
LE PICHON-LONGUEVILLE
CRU CLASSÉ EN 1855
PAUILLAC

CHATEAU PICHON-LONGUEVILLE
LE BARON de PICHON-LONGUEVILLE
2006
CRU CLASSÉ EN 1855
PAUILLAC

Lot 97

	Mixed 2010 & 2011 Château Pichon-Longueville, Lalande in Magnums				
	2010		magnums (6)		
	2011		magnums (3)		
	<i>In original wooden cases</i>				
103	9 magnums			<i>per lot</i>	HK\$12,000-18,000
	Mixed 2010 & 2011 Château Pichon-Longueville, Lalande				
	2010		(24)		
	2011		(6)		
	<i>In original wooden cases</i>				
104	30 bottles			<i>per lot</i>	HK\$20,000-32,000
	Mixed 2010 & 2011 Château Pichon-Longueville, Lalande				
	Réserve de la Comtesse				
	2010		(12)		
	2011		(12)		
	<i>In original wooden cases</i>				
105	24 bottles			<i>per lot</i>	HK\$5,500-8,500
	Château Duhart-Milon 2005				
	<i>Pauillac, 4ème cru classé</i>				
	<i>In six-bottle original wooden cases</i>				
106	24 bottles			<i>per lot</i>	HK\$12,000-18,000
	Château Duhart-Milon 2006				
	<i>Pauillac, 4ème cru classé</i>				
	<i>In six-bottle original wooden cases</i>				
107	24 bottles			<i>per lot</i>	HK\$8,500-13,000
	Mixed 2007 & 2008 Château Duhart-Milon				
	2007		(12)		
	2008		(12)		
	<i>In original wooden cases</i>				
108	24 bottles			<i>per lot</i>	HK\$9,000-14,000
	Mixed 2009 & 2010 Château Duhart-Milon				
	2009				
	<i>In original wooden case</i>		(12)		
	2010				
	<i>In six-bottle original wooden cases</i>		(12)		
109	24 bottles			<i>per lot</i>	HK\$11,000-17,000
	Mixed 2006 & 2008 Château Clerc-Milon				
	2006		(12)		
	2008		(12)		
	<i>In original wooden cases</i>				
110	24 bottles			<i>per lot</i>	HK\$8,500-14,000
	Mixed Formats of Château Clerc-Milon 2009 & 2010				
	2009		(12)		
	2010		magnums (3)		
	<i>In original wooden cases</i>				
111	3 magnums and 12 bottles			<i>per lot</i>	HK\$8,000-13,000
	Mixed Formats of Château Pontet-Canet 2010				
	2010		magnums (3)		
	2010		(6)		
	<i>In original wooden cases</i>				
112	3 magnums and 6 bottles			<i>per lot</i>	HK\$13,000-19,000
	Château Ducru-Beaucaillou 1982				
	<i>Saint-Julien, 2ème cru classé</i>				
	<i>Levels into neck</i>				
113	6 bottles			<i>per lot</i>	HK\$11,000-17,000
	Château Ducru-Beaucaillou 2006				
	<i>Saint-Julien, 2ème cru classé</i>				
	<i>In original wooden cases</i>				
114	24 bottles			<i>per lot</i>	HK\$18,000-26,000
	Mixed 2007 & 2008 Château Ducru-Beaucaillou				
	2007		(12)		
	2008		(12)		
	<i>In original wooden cases</i>				
115	24 bottles			<i>per lot</i>	HK\$17,000-26,000
	Château Ducru-Beaucaillou 2009				
	<i>Saint-Julien, 2ème cru classé</i>				
	<i>In original wooden case</i>				
116	12 bottles			<i>per lot</i>	HK\$17,000-24,000
	Mixed 2009 Château Ducru-Beaucaillou & La Croix de Beaucaillou				
	Château Ducru-Beaucaillou 2009		(12)		
	La Croix de Beaucaillou 2009		(12)		
	<i>In original wooden cases</i>				
117	24 bottles			<i>per lot</i>	HK\$20,000-28,000
	Mixed Formats of Château Ducru-Beaucaillou 2010				
	2010		magnums (6)		
	2010		(12)		
	<i>In original wooden cases</i>				
118	6 magnums and 12 bottles			<i>per lot</i>	HK\$28,000-40,000
	Château Léoville-Barton 2009				
	<i>Saint-Julien, 2ème cru classé</i>				
	<i>In original wooden case</i>				
119	12 bottles			<i>per lot</i>	HK\$5,500-8,500

Château Léoville-Barton 2009*Saint-Julien, 2ème cru classé**In original wooden cases*

120	24 bottles	<i>per lot</i> HK\$11,000-17,000
121	24 "	

Château Léoville-Barton 2010*Saint-Julien, 2ème cru classé**Six in three-magnum original wooden cases. Six in six-magnum original wooden case*

122	12 magnums	<i>per lot</i> HK\$15,000-22,000
-----	------------	----------------------------------

Château Léoville-Barton 2010*Saint-Julien, 2ème cru classé**Twelve in six-bottle original wooden cases. Twelve in original wooden case*

123	24 bottles	<i>per lot</i> HK\$15,000-22,000
-----	------------	----------------------------------

Mixed Formats of Château Léoville-Barton 2011**2011** magnums (6)**2011** (12)*In original wooden cases*

124	6 magnums and 12 bottles	<i>per lot</i> HK\$9,000-13,000
-----	--------------------------	---------------------------------

Château Léoville-Las-Cases 1982*Saint-Julien, 2ème cru classé**In original wooden case. Levels base of neck*

125	6 magnums	<i>per lot</i> HK\$28,000-42,000
-----	-----------	----------------------------------

2005 BORDEAUX VINTAGE REPORT

A vintage much heralded and achieving considerable acclaim from almost the moment the grapes were picked following well-nigh ideal growing conditions. The sort of year in which, unless the grower and winemaker were incompetent or suffered some misfortune, there was no excuse for making a poor wine.....

Before preparing my notes for publication, I was inclined to think that this was probably an over-hyped, overrated vintage. Having assembled them, however it is perfectly apparent that 2005 is unquestionably a vintage of the highest and, on the whole, most uniform quality. More than usual I have rated many wines 5 and 4-star; a few, in fact, hardly any, below 3-star. In short, thanks to the beneficial growing conditions and uniformly ripe grapes, sound winemaking and selection have made Bordeaux once again attractively drinkable - but at a price, not just at a high selling price but at the cost of individual character. In not 'all the same', there are insufficient contrasts. Too few faults and aberrations are, of course, welcome. But where is the drama, the excitement and undemonstrative finesse? Michael Broadbent M.W.

2005 年波爾多年份報告

這是備受推崇的年份，生長條件近乎完美，在收割果實後已獲得相當好評。在這種理想的年份，除非葡萄農和釀酒師非常不濟或不幸，否則釀造出劣品的機會微乎其微。

在整理酒評前，我經常認為此年份被過份吹噓和高估，但整理後卻發現 2005 年顯然是頂尖的年份，整體上品質非常一致。我給予五星和四星的葡萄酒比平常更多，獲三星以下的寥寥無幾。簡而言之，由於生長條件理想和果實一致成熟，仔細的釀酒和挑選過程令波爾多再度成為可口的葡萄酒，但卻售價高昂，而且沒有突出的個性。於未算千篇一律的出品中，卻沒有明顯的對比。較少失手或偏差自然受人歡迎，但卻失去了那份驚喜、興奮和含蓄細膩。葡萄酒大師米高·布羅德班

Château Léoville-Las-Cases 2005*Saint-Julien, 2ème cru classé**In original wooden case*

126	12 bottles	<i>per lot</i> HK\$16,000-24,000
-----	------------	----------------------------------

Château Léoville-Las-Cases 2006*Saint-Julien, 2ème cru classé**In original wooden cases*

127	12 bottles	<i>per lot</i> HK\$11,000-17,000
128	12 "	

Château Léoville-Las-Cases 2007*Saint-Julien, 2ème cru classé**In original wooden case*

129	12 bottles	<i>per lot</i> HK\$8,500-13,000
-----	------------	---------------------------------

Château Léoville-Las-Cases 2008*Saint-Julien, 2ème cru classé**In original wooden case*

130	12 bottles	<i>per lot</i> HK\$9,500-14,000
-----	------------	---------------------------------

Château Léoville-Las-Cases 2009*Saint-Julien, 2ème cru classé**In original wooden case*

131	12 bottles	<i>per lot</i> HK\$16,000-24,000
-----	------------	----------------------------------

Mixed Formats of Château Léoville-Las-Cases 2010**2010** magnums (3)**2010** (6)*In original wooden cases*

132	3 magnums and 6 bottles	<i>per lot</i> HK\$14,000-22,000
-----	-------------------------	----------------------------------

Clos du Marquis 2009*Saint-Julien**In original wooden cases*

133	24 bottles	<i>per lot</i> HK\$7,500-11,000
-----	------------	---------------------------------

Mixed Formats of Clos du Marquis 2010**2010** magnums (6)**2010** (12)*In original wooden cases*

134	6 magnums and 12 bottles	<i>per lot</i> HK\$7,000-10,000
-----	--------------------------	---------------------------------

Mixed Formats of Château Léoville-Poyferré 2010

2010 magnums (3)
2010 (6)

In original wooden cases

135 3 magnums and 6 bottles *per lot* HK\$8,000-12,000

Mixed 2006 & 2007 Château Langoa-Barton

2006 (12)
2007 (12)

In original wooden cases

136 24 bottles *per lot* HK\$6,000-9,000

Château Langoa-Barton 2009

Saint-Julien, 3ème cru classé

In original wooden cases

137 24 bottles *per lot* HK\$7,000-11,000

Château Langoa-Barton 2009

Saint-Julien, 3ème cru classé

In original wooden cases

138 36 bottles *per lot* HK\$11,000-16,000

Mixed Formats of Château Langoa-Barton 2010

2010 magnums (6)
2010 (12)

In original wooden cases

139 6 magnums and 12 bottles *per lot* HK\$6,500-9,500

Château Langoa-Barton 2010

Saint-Julien, 3ème cru classé

In original wooden cases

140 36 bottles *per lot* HK\$9,500-14,000

Mixed Formats of Château Langoa-Barton 2011

2011 magnums (6)
2011 (24)

In original wooden cases

141 6 magnums and 24 bottles *per lot* HK\$8,500-13,000

Mixed Formats of Haut-Médoc 2006 & 2010

Château Sociando-Mallet 2006 (12)

Château Bernadotte 2010 magnums (6)

Château Bernadotte 2010 (12)

In original wooden cases

142 6 magnums and 24 bottles *per lot* HK\$5,500-8,000

Mixed 1953 & 1955 Château Margaux

1953

Slightly stained label. Level mid-upper shoulder (1)

1955

Badly damaged label. BBR slip label. Level low-shoulder (1)

143 2 bottles *per lot* HK\$10,000-20,000

Mixed 1961 & 1966 Château Margaux

1961

One sign of old seepage. One damaged label. One label with Nicolas stamp. One US import slip label. Levels base of neck (2)

1966

Slightly damaged capsule. Slightly stained label. Level upper-shoulder (1)

144 3 bottles *per lot* HK\$12,000-17,000

Château Margaux 1982

Margaux, 1er cru classé

Three slightly stained labels, one slightly damaged label, vintage illegible. Levels base of neck

145 5 bottles *per lot* HK\$24,000-38,000

Château Margaux 1983

Margaux, 1er cru classé

Levels base of neck

146 7 bottles *per lot* HK\$22,000-32,000

Château Margaux 1989

Margaux, 1er cru classé

Levels into neck

147 6 bottles *per lot* HK\$15,000-22,000



Lot 136

Château Margaux 2000
 Margaux, 1er cru classé
 One slightly damaged label
 148 12 bottles per lot HK\$55,000-85,000

Château Margaux 2003
 Margaux, 1er cru classé
 Slightly damaged labels
 149 6 bottles per lot HK\$19,000-28,000

Château Margaux 2004
 Margaux, 1er cru classé
 In banded original wooden case
 150 12 bottles per lot HK\$28,000-42,000

Château Margaux 2005
 Margaux, 1er cru classé
 In banded original wooden case
 151 6 bottles per lot HK\$24,000-35,000

Château Margaux 2005
 Margaux, 1er cru classé
 In banded original wooden cases
 152 12 bottles per lot HK\$48,000-75,000
 153 12 "

Château Margaux 2006
 Margaux, 1er cru classé
 In banded original wooden cases
 154 12 bottles per lot HK\$28,000-42,000
 155 12 "

Château Margaux 2007
 Margaux, 1er cru classé
 In banded original wooden cases
 156 12 bottles per lot HK\$28,000-42,000
 157 12 "

Château Margaux 2008
 Margaux, 1er cru classé
 In banded original wooden cases
 158 12 bottles per lot HK\$28,000-42,000
 159 12 "
 160 12 "

Château Margaux 2009
 Margaux, 1er cru classé
 In banded original wooden cases
 161 12 bottles per lot HK\$50,000-75,000
 162 12 "

Château Margaux 2010
 Margaux, 1er cru classé
 In banded original wooden cases
 163 3 magnums per lot HK\$24,000-35,000
 164 3 "
 165 3 "

Château Margaux 2010
 Margaux, 1er cru classé
 In banded original wooden cases
 166 6 bottles per lot HK\$24,000-35,000
 167 6 "
 168 6 "

Château Margaux 2011
 Margaux, 1er cru classé
 In banded original wooden case
 169 12 bottles per lot HK\$28,000-42,000



	Château Margaux 2011 <i>Margaux, 1er cru classé</i> <i>In banded original wooden cases</i>	
170	18 bottles	per lot HK\$42,000-65,000
	Pavillon Blanc du Château Margaux 2003 <i>Margaux</i> <i>In banded original wooden case</i>	
171	12 bottles	per lot HK\$9,000-14,000
	Pavillon Blanc du Château Margaux 2004 <i>Margaux</i> <i>In banded original wooden cases</i>	
172	24 bottles	per lot HK\$24,000-35,000
	Pavillon Blanc du Château Margaux 2005 <i>Margaux</i> <i>In banded original wooden case</i>	
173	12 bottles	per lot HK\$11,000-17,000
	Pavillon Blanc du Château Margaux 2008 <i>Margaux</i> <i>In banded six-bottle original wooden case</i>	
174	12 bottles	per lot HK\$13,000-19,000
	Pavillon Blanc du Château Margaux 2009 <i>Margaux</i> <i>In banded original wooden cases</i>	
175	18 bottles	per lot HK\$20,000-30,000
	Mixed 2010 & 2011 Pavillon Blanc du Château Margaux	
	2010 (6)	
	2011 (6)	
	<i>In banded original wooden cases</i>	
176	12 bottles	per lot HK\$12,000-18,000
	Pavillon Rouge du Château Margaux 2004 <i>Margaux</i> <i>In banded original wooden case</i>	
177	12 bottles	per lot HK\$9,500-14,000
	Pavillon Rouge du Château Margaux 2004 <i>Margaux</i> <i>In banded original wooden cases</i>	
178	24 bottles	per lot HK\$19,000-28,000
179	24 "	
	Pavillon Rouge du Château Margaux 2005 <i>Margaux</i> <i>In banded original wooden cases</i>	
180	24 bottles	per lot HK\$22,000-35,000

2006 BORDEAUX VINTAGE REPORT

This was a vintage that got off to a tremendous start with an efficient flowering followed by a hot and dry June - July, rather similar to 1995. At this stage, we thought we would be in for another rich and powerful wine. Then August was a bit of a lost month, wet and cool. There was little detrimental effect on the grapes but it shaped the vintage's potential character from something potentially very rich into something tighter and more "classic". A fine September quickly ripened the fruit but there were showers just before and during harvest, which just hardened up the tannins in the final stages and added to the tightly-wound style of the vintage. So the wines, whilst beautifully ripe, have a tannic edge to them that will take a few more years to shake off. This is a true blue Bordeaux vintage, all tightness and tautness, reserved rather than flamboyant, with similarities to, but considered better than, the '66 and '88. Some can be drunk with pleasure already but most will be better after another decade or so. Bill Blatch

2006 年波爾多年份報告

此年份起步絕佳，開花期順暢，隨後 6 月及 7 月天氣炎熱乾燥，與 1995 年類似。當時大家以為能再度釀出豐沛剛勁的葡萄酒。但 8 月潮濕涼爽，未如理想，雖然對果實沒有太大影響，卻削弱了令此年份的潛力，變得更集中濃厚、更傳統。9 月晴朗天氣令葡萄迅速成熟，但收割前和期間下雨，令單寧在最後階段變硬，令酸度更集中。儘管果實成熟，葡萄酒卻帶有濃重的單寧，需要陳化數年才能散去。這是典型的沉鬱波爾多紅酒，濃厚集中，含蓄內斂，與 1966 年及 1988 年相似，但稍佳。一部分出品已可以開瓶享用，但大部分最好再陳年十年以上。比爾·布拉齊

	Pavillon Rouge du Château Margaux 2006 <i>Margaux</i> <i>In banded original wooden case</i>	
181	12 bottles	per lot HK\$9,500-14,000
	Pavillon Rouge du Château Margaux 2008 <i>Margaux</i> <i>In banded original wooden cases</i>	
182	24 bottles	per lot HK\$20,000-30,000
183	24 "	
	Pavillon Rouge du Château Margaux 2009 <i>Margaux</i> <i>In banded original wooden cases</i>	
184	12 bottles	per lot HK\$10,000-15,000
185	12 "	
	Mixed Formats of Pavillon Rouge du Château Margaux 2010	
	2010 magnums (3)	
	2010 (6)	
	<i>In banded original wooden cases</i>	
186	3 magnums and 6 bottles	per lot HK\$10,000-15,000
	Pavillon Rouge du Château Margaux 2010 <i>Margaux</i> <i>In banded original wooden case</i>	
187	12 bottles	per lot HK\$10,000-15,000
	Pavillon Rouge du Château Margaux 2011 <i>Margaux</i> <i>In banded original wooden case</i>	
188	12 bottles	per lot HK\$9,500-14,000

Château Rauzan-Ségla

Located a stone's throw from the village of Margaux, Château Rauzan-Ségla occupies 70 hectares of vineyards.

In 1661, Pierre Desmezières de Rauzan purchased an estate which he named after himself. This great Bordeaux wine merchant recognized the exceptional terroir that, nurtured by generations that succeeded him, was to gain an excellent reputation worldwide. This was confirmed in the famous 1855 classification, when the Château was included among the Second Growths.

Its terroir, composed of fine, deep gravels offers natural drainage at various depths thus helping express the subtleness of each grape variety. Each plot of the vineyard is picked by hand and vinified separately in thermo-regulated stainless steel vats. The wines age in French oak barrels for 18 months.

The current owners since 1994, Chanel have led a complete renovation of this Estate: painstaking soil preparation, green harvesting, berries selection on sorting tables, reorganisation of the cellars and of the vatroom.

Its rich nectar delicately exudes subtle fragrances of red and black fruit. On the palate, the texture is unctuous and refined, remarkably complex and announces a considerable ageing potential in the bottle. A wine always faithful to the appellation Margaux.

"We have lived, generation after generation, in the very heart of this Land, cradled between the Estuary and the Ocean by the flow of the passing seasons, one with Mother Nature, in this singular province known as Margaux. Our life here is dedicated to Vine and Wine, a unique world where savoir-faire and passion are indistinguishable. All our ancestors before us nurtured the vineyard of Rauzan-Ségla with such perseverance that its true richness and intensity could be revealed. For over 350 years our wines have crossed the centuries, testifying, and never more so than now, to the excellence of our Cru. It is this timeless Passion that we would like to share with you today." Nicolas Audebert – General Manager

魯臣世家

魯臣世家與瑪歌莊只是咫尺之遙，葡萄園佔地 70 公頃。

1661 年由皮埃爾·戴木祖·德·魯臣收購，並以自己的名字命名。這位偉大的波爾多酒商發現該地風土極為出色，只要後人好好打理葡萄園，定能蜚聲國際。魯臣世家在著名的 1855 年等級評定獲得二級酒莊資格。

由深層砂礫土形成的風土，在不同深度皆能確保自然疏水，有助展現每種葡萄的細緻特質。每塊田的葡萄皆由人手採摘，分別放在有溫度調節的不鏽鋼桶發酵。葡萄酒在法國舊木桶內陳年 18 個月。

現任業主香奈兒集團於 1994 年買下酒莊，並開展龐大的翻新工程：艱鉅的土壤預備工作、環保收割方法、設置葡萄驗收工作枱去篩選葡萄，以及整頓酒窖和釀酒廠房。

葡萄酒洋溢濃鬱香氣，帶微微的紅黑果實氣息。入口圓潤細緻、非常複雜，展現優秀的陳年能力。這是忠於瑪歌風土的葡萄酒。

「我們世世代代都在這片土地生活，就是這獨一無二的瑪歌村；季節更替，讓我們感受到河口和海洋的滋養，同時有大地之母的呵護。我們將一生奉獻給葡萄藤及葡萄酒——個工藝和熱誠密不可分的獨特世界。憑藉祖先堅毅不屈的精神，多年悉心培育魯臣世家的葡萄園，讓它展現真正的豐盛和力量。我們的佳釀在過去 350 年間穿越多個世紀，至今最能夠表現出酒莊的卓越成就。今天，我們希望共你分享這份超越時間的熱誠。」尼古拉·奧德博 - 總經理

Château Rauzan-Ségla 2006

Margaux, 2ème cru classé
In original wooden cases

189 24 bottles per lot HK\$7,500-11,000

Château Rauzan-Ségla 2006

Margaux, 2ème cru classé
In original wooden cases

190 36 bottles per lot HK\$11,000-17,000

2007 BORDEAUX VINTAGE REPORT

This was a last-minute turnaround vintage. It was overcast, grey and showery right up to the end of August, and at this time got itself something of an indifferent reputation which unfortunately sometimes stuck with it to the end, in spite of the sudden and magical explosion into a wonderful hot and dry Indian summer during September and October, well into the harvest. The wines are of course not as strong as 2006: the vines just didn't get enough sunshine during the summer. But the final ripening was perfect, at least for those whose vineyard was in good shape and avoided rot, which is all the serious ones, and the wines immediately showed a lovely softness that has made them come around quickly and made them perfect for early drinking, while we wait for the 05's and 06's. Bill Blatch

2007 年波爾多年份報告

在最後一刻扭轉劣勢的年份。8 月底前一直天陰多雲，有零散驟雨，予人的印象平平，雖然 9 月至 10 月突然出現炎熱乾燥的天氣，並一直延續至收成，但部分已無法扭轉事實。由於夏季沒有足夠陽光，出品當然比不上 2006 年，但對於認真護理葡萄樹、成功防止根部腐爛的葡萄園而言，最後的成熟過程理想。葡萄酒入口順滑，迅速展現個性，適宜及早飲用，甚至比 2005 年和 2006 年更早。比爾·布拉齊

Château Rauzan-Ségla 2007

Margaux, 2ème cru classé
In original wooden cases

191 24 bottles per lot HK\$7,500-11,000
192 24 "

Château Rauzan-Ségla 2008

Margaux, 2ème cru classé
In original wooden cases

193 36 bottles per lot HK\$10,000-15,000

Château Rauzan-Ségla 2009

Margaux, 2ème cru classé
In six-magnum original wooden cases

194 12 magnums per lot HK\$12,000-18,000

Château Rauzan-Ségla 2009

Margaux, 2ème cru classé
In original wooden cases

195 24 bottles per lot HK\$12,000-18,000

Château Rauzan-Ségla 2010

Margaux, 2ème cru classé
In original wooden case

196 3 double-magnums per lot HK\$6,000-9,000

	Château Rauzan-Ségla 2010 <i>Margaux, 2ème cru classé</i> Six in three-magnum original wooden cases. Six in six-magnum original wooden case	
197	12 magnums	per lot HK\$12,000-18,000
	Château Rauzan-Ségla 2010 <i>Margaux, 2ème cru classé</i> In original wooden case	
198	12 bottles	per lot HK\$6,000-9,000
	Château Rauzan-Ségla 2010 <i>Margaux, 2ème cru classé</i> In original wooden cases	
199	24 bottles	per lot HK\$12,000-18,000
	Château Rauzan-Ségla 2011 <i>Margaux, 2ème cru classé</i> In original wooden cases	
200	12 magnums	per lot HK\$7,500-11,000
	Château Rauzan-Ségla 2011 <i>Margaux, 2ème cru classé</i> In original wooden cases	
201	24 bottles	per lot HK\$7,500-11,000
	Château Palmer 1966 <i>Cantenac (Margaux), 3ème cru classé</i> Excellent appearance. Level into neck	
202	1 bottle	per lot HK\$3,500-5,000
	Château Palmer 2004 <i>Cantenac (Margaux), 3ème cru classé</i>	
203	6 bottles	per lot HK\$6,000-9,000
	Château Palmer 2005 <i>Cantenac (Margaux), 3ème cru classé</i> In original wooden case	
204	12 bottles	per lot HK\$19,000-28,000
	Château Palmer 2006 <i>Cantenac (Margaux), 3ème cru classé</i> In original wooden cases	
205	12 bottles	per lot HK\$12,000-18,000
206	12 "	

	Château Palmer 2008 <i>Cantenac (Margaux), 3ème cru classé</i> In original wooden case	
207	12 bottles	per lot HK\$13,000-19,000
	Château Palmer 2010 <i>Cantenac (Margaux), 3ème cru classé</i> In three-magnum original wooden cases	
208	6 magnums	per lot HK\$17,000-24,000
	Château Palmer 2010 <i>Cantenac (Margaux), 3ème cru classé</i> In original wooden cases	
209	12 bottles	per lot HK\$17,000-24,000
	Château Palmer 2011 <i>Cantenac (Margaux), 3ème cru classé</i> In original wooden cases	
210	12 bottles	per lot HK\$13,000-19,000
	Alter Ego de Palmer 2009 <i>Margaux</i> In original wooden cases	
211	24 bottles	per lot HK\$11,000-16,000
	Château d'Issan 2009 <i>Cantenac (Margaux), 3ème cru classé</i> In original wooden case	
212	12 bottles	per lot HK\$4,500-6,500

Château Haut-Brion

"And there drank a sort of French wine, called Ho Bryan (sic), that hath a good and most particular taste that I never met with."

Samuel Pepys (April 10, 1663)

The oldest of the Bordeaux classified growths. The inventor of the new French Claret "a new style of wine" in the seventeenth century. The world's first luxury brand... whenever Château Haut-Brion is mentioned, one quickly runs out of superlatives. This wine is the embodiment of two millenia of tradition and plays a pivotal role in the worldwide history of wine. Purchased in 1935 by Mr. Clarence Dillon, it is now managed by his great Grandson, Prince Robert of Luxembourg, Chairman and CEO of Domaine Clarence Dillon.

侯伯王酒莊

「當地喝一種名叫 Ho Bryan 的法國葡萄酒，擁有我從未嚐過的獨特美味。」

賽繆爾·皮普斯（1663年4月10日）

侯伯王酒莊是波爾多歷史最悠久的列級酒莊，在十七世紀研創出全新的法國紅酒，成為世上第一個奢華品牌，最讚譽的言辭亦不足以描述侯伯王酒莊的出品。酒莊的葡萄酒體現兩千年的釀酒傳統，並在全球葡萄酒史上擔當重要的角色。酒莊於1935年由克蘭斯·帝龍買下，現時由其曾孫打理，亦即克蘭斯·帝龍酒莊主席兼行政總裁盧森堡侯貝王子。

Château Haut-Brion 1982
Pessac (Graves), 1er cru classé
Slightly damaged capsules. Slightly stained labels, two slightly damaged. Levels four 2cms, two 2.5cms
 213 6 bottles *per lot* HK\$26,000-40,000

Château Haut-Brion 1989
Pessac (Graves), 1er cru classé
Two slightly damaged labels. Levels 1cm
 214 6 bottles *per lot* HK\$55,000-85,000

Château Haut-Brion 2004
Pessac (Graves), 1er cru classé
In original wooden case
 215 12 bottles *per lot* HK\$24,000-35,000

2005 BORDEAUX VINTAGE REPORT

A vintage much heralded and achieving considerable acclaim from almost the moment the grapes were picked following well-nigh ideal growing conditions. The sort of year in which, unless the grower and winemaker were incompetent or suffered some misfortune, there was no excuse for making a poor wine.....

Before preparing my notes for publication, I was inclined to think that this was probably an over-hyped, overrated vintage. Having assembled them, however it is perfectly apparent that 2005 is unquestionably a vintage of the highest and, on the whole, most uniform quality. More than usual I have rated many wines 5 and 4-star; a few, in fact, hardly any, below 3-star. In short, thanks to the beneficial growing conditions and uniformly ripe grapes, sound winemaking and selection have made Bordeaux once again attractively drinkable - but at a price, not just at a high selling price but at the cost of individual character. In not 'all the same', there are insufficient contrasts. Too few faults and aberrations are, of course, welcome. But where is the drama, the excitement and undemonstrative finesse? Michael Broadbent M.W.

2005 年波爾多年份報告

這是備受推崇的年份，生長條件近乎完美，在收割果實後已獲得相當好評。在這種理想的年份，除非葡萄農和釀酒師非常不濟或不幸，否則釀造出劣品的機會微乎其微。

在整理酒評前，我經常認為此年份被過份吹噓和高估，但整理後卻發現 2005 年顯然是頂尖的年份，整體上品質非常一致。我給予五星和四星的葡萄酒比平常更多，獲三星以下的寥寥無幾。簡而言之，由於生長條件理想和果實一致成熟，仔細的釀酒和挑選過程令波爾多再度成為可口的葡萄酒，但卻售價高昂，而且沒有突出的個性。於未算千篇一律的出品中，卻沒有明顯的對比。較少失手或偏差自然受人歡迎，但卻失去了那份驚喜、興奮和含蓄細膩。葡萄酒大師米高·布羅德班

Château Haut-Brion 2005
Pessac (Graves), 1er cru classé
In original wooden case
 216 12 bottles *per lot* HK\$48,000-75,000

Château Haut-Brion 2006
Pessac (Graves), 1er cru classé
In original wooden cases
 217 18 bottles *per lot* HK\$42,000-65,000

Château Haut-Brion 2007
Pessac (Graves), 1er cru classé
In original wooden case
 218 12 bottles *per lot* HK\$24,000-35,000

Château Haut-Brion 2007
Pessac (Graves), 1er cru classé
In original wooden cases
 219 18 bottles *per lot* HK\$35,000-55,000

Château Haut-Brion 2008
Pessac (Graves), 1er cru classé
In original wooden cases
 220 18 bottles *per lot* HK\$38,000-60,000

Château Haut-Brion 2009
Pessac (Graves), 1er cru classé
In original wooden case
 221 6 bottles *per lot* HK\$24,000-38,000

Château Haut-Brion 2010
Pessac (Graves), 1er cru classé
In original wooden case
 222 3 magnums *per lot* HK\$24,000-38,000

Château Haut-Brion 2010
Pessac (Graves), 1er cru classé
In six-bottle original wooden cases
 223 12 bottles *per lot* HK\$50,000-75,000

Château Haut-Brion 2011
Pessac (Graves), 1er cru classé
In original wooden cases
 224 18 bottles *per lot* HK\$38,000-55,000

Le Bahans du Haut-Brion 2005
Pessac-Léognan
In original wooden cases
 225 24 bottles *per lot* HK\$15,000-22,000

Le Bahans du Haut-Brion 2006
Pessac-Léognan
In original wooden cases
 226 24 bottles *per lot* HK\$14,000-20,000

2008 BORDEAUX VINTAGE REPORT

This was a year when the vine was in no hurry to go anywhere, taking its time to bud, flower and ripen its grapes right through to the latest harvest since 1978. Like all late vintages, 1988, 1998 and 1978, the fruit character is of red rather than black fruit, but the similarity ends here, the 2008's having much more power and concentration than all of these, imparted by a sensationally fine September - October. Thus they have strong dark colours, a fullness of middle-weight and ripeness of tannin as well as all the freshness of these red fruits. Some are just beginning to show a nice balance now but most will require a few more years. The wines were put on the market in the midst of the banking crisis's second dip, and were consequently very fairly priced. Bill Blatch

2008 年波爾多年份報告

這一年的葡萄穩步生長，按時發芽、開花和成熟，是 1978 年以來最遲收成的一年。與 1988、1998 和 1978 年一樣，紅葡萄的特質比黑葡萄更突出，但勁道和集中度方面卻更勝一籌，全因 9 月及 10 月的絕佳天氣所致。因此，葡萄酒色澤深邃，中度飽滿，單寧成熟，擁有紅葡萄的清新氣息。部分出品已非常均衡圓熟，但多數還需要陳化數年。葡萄酒推出市場之際正值金融危機後的第二個谷底，因此價格相當合理。比爾·布拉齊

Le Clarence de Haut-Brion 2008

Pessac-Léognan

In original wooden cases

227 24 bottles per lot HK\$12,000-18,000
228 24 "

Le Clarence de Haut-Brion 2009

Pessac-Léognan

In original wooden cases

229 12 bottles per lot HK\$5,500-8,500
230 12 "
231 12 "

Mixed Formats of Le Clarence de Haut-Brion 2010

2010

magnums (6)

2010

(12)

In original wooden cases

232 6 magnums and 12 bottles per lot HK\$15,000-22,000

Château La Mission-Haut-Brion 1961

Pessac (Graves), cru classé

One slightly damaged capsule. Slightly stained labels, one slightly damaged. Four Mähler-Besse slip labels. Levels three base of neck, three top-shoulder

233 6 bottles per lot HK\$120,000-180,000

Château La Mission-Haut-Brion 1982

Pessac (Graves), cru classé

Excellent appearance. Levels into neck

234 6 bottles per lot HK\$35,000-50,000



Lot 232

Château La Mission-Haut-Brion 1986*Pessac (Graves), cru classé**Slightly stained and one slightly damaged labels. Levels base of neck*235 6 bottles *per lot* HK\$9,500-14,000**2003 BORDEAUX VINTAGE REPORT**

The year of the heatwave. Untypical reds entirely due to the exceptionally hot summer and early harvest. The early part of the growing season was unexceptional, satisfactory flowering predicting an appropriately early harvest. However temperatures in August were up to 40°C compared to "normal" Bordeaux heatwaves of around 34-35°C. This resulted in an unusually precocious harvest, producing a low volume of small, concentrated, very ripe grapes with thick skins.

Some great wines were made but several were disappointing. On the whole these are attractive wines. I tasted a very extensive range, mainly noted as *en primeur* wines in the spring of 2004. Michael Broadbent M.W.

2003 年波爾多年份報告

這是熱浪肆虐的一年，酷暑和提早收割造就與別不同的紅酒。生長期初段一切如常，開花情況理想，預示能提早收割。但 8 月氣溫飆升至攝氏 40 度，遠高於波爾多一般大約攝氏 34 至 35 度的熱浪，因此令收成非常早熟，收割的葡萄極少，果實小而厚皮，酸度集中和熟透。

部分莊園的葡萄酒非常精彩，但部分則令人失望，整體而言仍然相當吸引。我嚐過該年份的多款出品，主要為 2004 年春季的期酒。葡萄酒大師米高·布羅德班

Château La Mission-Haut-Brion 2003*Pessac (Graves), cru classé**In original wooden case*236 6 bottles *per lot* HK\$7,000-10,000**Château La Mission-Haut-Brion 2004***Pessac (Graves), cru classé**In original wooden cases*237 24 bottles *per lot* HK\$26,000-38,000**Château La Mission-Haut-Brion 2005***Pessac (Graves), cru classé**In original wooden cases*238 12 bottles *per lot* HK\$35,000-50,000

239 12 "

240 12 "

Château La Mission-Haut-Brion 2006*Pessac (Graves), cru classé**In original wooden case*241 6 bottles *per lot* HK\$7,000-10,000**Château La Mission-Haut-Brion 2006***Pessac (Graves), cru classé**In original wooden cases*242 18 bottles *per lot* HK\$20,000-32,000**Château La Mission-Haut-Brion 2007***Pessac (Graves), cru classé**In original wooden cases*243 12 bottles *per lot* HK\$11,000-16,000

244 12 "

Château La Mission-Haut-Brion 2008*Pessac (Graves), cru classé**In original wooden case*245 6 bottles *per lot* HK\$7,000-10,000**Château La Mission-Haut-Brion 2008***Pessac (Graves), cru classé**In original wooden cases*246 12 bottles *per lot* HK\$14,000-20,000

247 12 "

248 12 "

Château La Mission-Haut-Brion 2009*Pessac (Graves), cru classé**In original wooden case*249 6 bottles *per lot* HK\$15,000-22,000**Château La Mission-Haut-Brion 2009***Pessac (Graves), cru classé**In original wooden case*250 12 bottles *per lot* HK\$30,000-45,000**Château La Mission-Haut-Brion 2010***Pessac (Graves), cru classé**In original wooden cases*251 9 magnums *per lot* HK\$45,000-70,000**Château La Mission-Haut-Brion 2010***Pessac (Graves), cru classé**In original wooden case*252 6 bottles *per lot* HK\$15,000-22,000**Château La Mission-Haut-Brion 2010***Pessac (Graves), cru classé**In original wooden case*253 12 bottles *per lot* HK\$30,000-45,000**Mixed Formats of Château La Mission-Haut-Brion 2011**

2011 magnums (3)

2011 (6)

*In original wooden cases*254 3 magnums and 6 bottles *per lot* HK\$13,000-19,000

Château Latour-Martillac Blanc 2009

Pessac-Léognan

In original wooden cases

255 24 bottles *per lot* HK\$5,500-8,000**Château Haut-Bailly 2005**

Léognan (Graves), cru classé

In original wooden cases

256 12 bottles *per lot* HK\$7,000-10,000

257 12 "

258 12 "

Château Haut-Bailly 2008

Léognan (Graves), cru classé

In original wooden case

259 12 bottles *per lot* HK\$5,500-8,500**Mixed 2010 & 2011 Château Haut-Bailly in Magnums****2010**

magnums (6)

2011

magnums (3)

In original wooden cases

260 9 magnums *per lot* HK\$9,000-14,000**Mixed 2010 & 2011 Château Haut-Bailly****2010**

(12)

2011

(6)

In original wooden cases

261 18 bottles *per lot* HK\$9,000-14,000**Château Pape-Clément Blanc 2009**

Pessac-Léognan

In six-bottle original wooden cases

262 12 bottles *per lot* HK\$19,000-28,000**Mixed Formats of Château Pape-Clément Blanc 2010****2010**

magnums (3)

2010

(6)

In original wooden cases

263 3 magnums and 6 bottles *per lot* HK\$7,500-11,000**Château Pape-Clément 2009**

Pessac (Graves), cru classé

In original wooden case

264 12 bottles *per lot* HK\$10,000-15,000**Mixed Formats of Château Pape-Clément 2010****2010**

magnums (3)

2010

(6)

In original wooden cases

265 3 magnums and 6 bottles *per lot* HK\$15,000-22,000**Mixed Formats of Domaine de Chevalier Blanc 2010 & 2011****2010**

magnums (3)

2011

magnums (3)

2011

(6)

In original wooden cases

266 6 magnums and 6 bottles *per lot* HK\$8,000-12,000**Mixed Formats of Domaine de Chevalier 2010****2010**

magnums (3)

2010

(6)

In original wooden cases

267 3 magnums and 6 bottles *per lot* HK\$4,800-7,500

Lot 266

SATURDAY 9 SEPTEMBER - 11.00AM

SESSION II: Lots 268-476

FINE AND RARE WINES: MELINA & NK YONG'S CELLAR

佳士得名釀

268	Château Lafleur 1975 <i>Pomerol</i> <i>Slightly stained labels, one slightly damaged. Levels base of neck</i> 6 bottles	<i>per lot</i> HK\$110,000-170,000	277	Château L'Église-Clinet 2008 <i>Pomerol</i> <i>In six-bottle original wooden cases</i> 24 bottles	<i>per lot</i> HK\$20,000-30,000
269	Château Lafleur 1982 <i>Pomerol</i> <i>Slightly stained labels, two slightly damaged. Levels base of neck</i> 6 bottles	<i>per lot</i> HK\$130,000-200,000	278	Château L'Église-Clinet 2009 <i>Pomerol</i> <i>In six-bottle original wooden cases</i> 12 bottles	<i>per lot</i> HK\$24,000-35,000
270	Château Lafleur 2004 <i>Pomerol</i> <i>In six-bottle original wooden cases</i> 12 bottles	<i>per lot</i> HK\$24,000-35,000	279	Château L'Évangile 2006 <i>Pomerol</i> <i>In original wooden cases</i> 24 bottles	<i>per lot</i> HK\$14,000-20,000
271	12 "				
272	Château Lafleur 2006 <i>Pomerol</i> <i>In six-bottle original wooden cases</i> 12 bottles	<i>per lot</i> HK\$35,000-55,000	280	Château L'Évangile 2010 <i>Pomerol</i> <i>In six-bottle original wooden cases</i> 12 bottles	<i>per lot</i> HK\$14,000-22,000
273	Château Lafleur 2007 <i>Pomerol</i> <i>In six-bottle original wooden cases</i> 12 bottles	<i>per lot</i> HK\$18,000-26,000		Mixed 2006 & 2009 Pomerol Château Rouget 2006 <i>In original wooden cases</i> (24) Château Nenin 2009 <i>In original carton</i> (6) 30 bottles	<i>per lot</i> HK\$8,500-12,000
274	Les Pensées de Lafleur 2004 <i>Pomerol</i> <i>In six-bottle original wooden cases</i> 12 bottles	<i>per lot</i> HK\$4,800-7,500		Mixed 1959 & 1970 Château Trotanoy 1959 <i>Slightly damaged label. Level base of neck</i> (1) 1970 <i>Slightly stained label. Level into neck</i> (1) 2 bottles	<i>per lot</i> HK\$11,000-18,000
275	Mixed 2006 Château L'Église-Clinet & La Petite Église Château L'Église-Clinet 2006 (12) La Petite Église 2006 (12) <i>In original wooden cases</i> 24 bottles	<i>per lot</i> HK\$12,000-19,000	283	Mixed 2004 & 2006 Château Trotanoy 2004 (12) 2006 (12) <i>In six-bottle original wooden cases</i> 24 bottles	<i>per lot</i> HK\$16,000-24,000
276	Château L'Église-Clinet 2007 <i>Pomerol</i> <i>In original wooden cases</i> 30 bottles	<i>per lot</i> HK\$13,000-20,000	284	Clos L'Église 2005 <i>Pomerol</i> <i>In original wooden cases</i> 18 bottles	<i>per lot</i> HK\$12,000-18,000

Petrus 1975*Pomerol, cru exceptionnel**Slightly damaged capsules. One slightly stained and one slightly damaged labels. Levels three base of neck, two top-shoulder, one upper-shoulder*285 6 bottles *per lot* HK\$65,000-95,000**Petrus 1982***Pomerol, cru exceptionnel**In original wooden case. One very slightly damaged label, otherwise excellent appearance. Levels into neck*286 12 bottles *per lot* HK\$260,000-400,000**Petrus 1985***Pomerol, cru exceptionnel**Two slightly damaged labels. Levels base of neck*287 6 bottles *per lot* HK\$60,000-90,000**Petrus 1989***Pomerol, cru exceptionnel**In original wooden case. Excellent appearance. Level into neck*288 6 bottles *per lot* HK\$130,000-200,000**Petrus 1998***Pomerol, cru exceptionnel**One slightly damaged label*289 3 bottles *per lot* HK\$48,000-70,000**2002 BORDEAUX VINTAGE REPORT**

Until I assembled my notes, I had not realised how much I liked these 02's. It was a much better vintage than had been feared. A small crop but, because of a dismal market, the wines were moderately priced and are still good value. A claret drinker's vintage, not for investment.

For the growers, the conditions were nerve-wracking. After normal bud break the vital flowering period was catastrophic – cold, wet, erratic and prolonged. Coulure throughout the region was followed by millerandage, and the potential crop was halved. Merlot was particularly badly affected. However, not unlike the 1978 vintage, sun and warmth from around 10 September followed by an Indian summer saved the day. After severe selection of grapes some were excellent wines made. It was a decidedly 'Left Bank' year. Michael Broadbent M.W.

2002 年波爾多年份報告

在整理所有評語後，我發現自己很喜歡 2002 年。此年份比外間預測要好得多。雖然收成不多，但因為市況不振，葡萄酒定價相宜，至今仍然物有所值。此年份最適合飲用，而非投資。

這年的天氣令葡萄園憂心不已。在正常發芽後，關鍵的開花期卻遇上長時間寒冷潮濕的反覆天氣。區內葡萄出現落果和大小不一的現象，令收成減半，梅洛葡萄問題尤其嚴重。然而，此年的情況與 1978 年相似，9 月 10 日起天氣放晴和回暖，隨後出現熱浪，及時挽救了收成。在嚴格挑選葡萄後，成功釀製出色的葡萄酒，但左岸產區卻獨領風騷。葡萄酒大師米高·布羅德班

Petrus 2002*Pomerol, cru exceptionnel**Lot 290: In original wooden case*290 6 bottles *per lot* HK\$70,000-100,000

291 6 "

Petrus 2003*Pomerol, cru exceptionnel*292 11 bottles *per lot* HK\$130,000-190,000**Le Pin 2004***Pomerol*293 6 bottles *per lot* HK\$60,000-90,000**Le Pin 2005***Pomerol**In original wooden case*294 6 bottles *per lot* HK\$90,000-140,000**Le Pin 2006***Pomerol**In original wooden case*295 6 bottles *per lot* HK\$65,000-95,000**Le Pin 2007***Pomerol**In original wooden case*296 6 bottles *per lot* HK\$60,000-90,000

Lot 286

Le Pin 2008
Pomerol
One slightly damaged label
 297 3 bottles *per lot* HK\$32,000-48,000

Le Pin 2009
Pomerol
 298 3 bottles *per lot* HK\$55,000-85,000

Le Pin 2010
Pomerol
 299 3 bottles *per lot* HK\$55,000-85,000

Vieux-Château-Certain

Famed Pomerol producer making classic Right Bank claret with a mixture of Merlot, Cabernet Franc and a splash of Cabernet Sauvignon. The Château also produces a second wine named La Gravette de Certain.

老賽丹

老賽丹是波美侯右岸的著名酒莊，作品混雜了梅洛、品麗珠以及少許赤霞珠，風味經典雅緻，同時生產名為賽丹哥拉維特的二軍酒。

Vieux-Château-Certain 2004
Pomerol
In original wooden cases
 300 12 bottles *per lot* HK\$8,000-12,000
 301 12 "

Vieux-Château-Certain 2005
Pomerol
In original wooden case
 302 12 bottles *per lot* HK\$15,000-22,000

Vieux-Château-Certain 2006
Pomerol
In original wooden cases
 303 12 bottles *per lot* HK\$11,000-17,000
 304 12 "

Vieux-Château-Certain 2007
Pomerol
In original wooden cases
 305 24 bottles *per lot* HK\$12,000-18,000

Vieux-Château-Certain 2008
Pomerol
In original wooden cases
 306 12 bottles *per lot* HK\$7,000-11,000
 307 12 "

Vieux-Château-Certain 2009
Pomerol
In original wooden cases
 308 24 bottles *per lot* HK\$35,000-50,000

Vieux-Château-Certain 2010
Pomerol
In original wooden case
 309 12 bottles *per lot* HK\$20,000-30,000

Vieux-Château-Certain 2011
Pomerol
In original wooden case
 310 12 bottles *per lot* HK\$8,500-13,000

Vieux-Château-Certain 2014
Pomerol
In original wooden cases
 311 24 bottles *per lot* HK\$22,000-32,000

Château La Fleur de Bouïard 2009
Pomerol, Lalande-de-Pomerol
In original wooden cases
 312 36 bottles *per lot* HK\$8,000-12,000

Château La Fleur de Bouïard 2010
Pomerol, Lalande-de-Pomerol
In original wooden cases
 313 24 bottles *per lot* HK\$4,500-6,500



	Château La Fleur de Bouïard Le Plus 2009 <i>Pomerol, Lalande-de-Pomerol</i> <i>In six-bottle original wooden cases</i>				Château Figeac 1966 <i>Saint-Émilion, 1er grand cru classé</i> <i>Slightly damaged capsules. Slightly stained labels. Levels one top-shoulder, one upper-shoulder</i>			
314	24 bottles			<i>per lot</i> HK\$15,000-22,000	323	2 bottles		<i>per lot</i> HK\$3,200-4,800
	Château La Fleur de Bouïard Le Plus 2010 <i>Pomerol, Lalande-de-Pomerol</i> <i>In three-bottle original wooden cases</i>					Château Figeac 2006 <i>Saint-Émilion, 1er grand cru classé</i> <i>In original wooden case</i>		
315	18 bottles			<i>per lot</i> HK\$10,000-15,000	324	24 bottles		<i>per lot</i> HK\$13,000-19,000
	Château Valandraud 2005 <i>Saint-Émilion, grand cru classé</i> <i>In original wooden case</i>					Château Figeac 2007 <i>Saint-Émilion, 1er grand cru classé</i> <i>In six-bottle original wooden cases</i>		
316	12 bottles			<i>per lot</i> HK\$12,000-18,000	325	12 bottles		<i>per lot</i> HK\$5,500-8,000
	Château Valandraud 2006 <i>Saint-Émilion, grand cru classé</i> <i>In original wooden cases</i>					Château Figeac 2008 <i>Saint-Émilion, 1er grand cru classé</i> <i>In original wooden cases</i>		
317	36 bottles			<i>per lot</i> HK\$26,000-40,000	326	24 bottles		<i>per lot</i> HK\$11,000-16,000
	Château Valandraud 2007 <i>Saint-Émilion, grand cru classé</i> <i>In original wooden case</i>					Château Figeac 2009 <i>Saint-Émilion, 1er grand cru classé</i> <i>In original wooden case</i>		
318	12 bottles			<i>per lot</i> HK\$8,000-12,000	327	12 bottles		<i>per lot</i> HK\$12,000-18,000
	Château Valandraud 2008 <i>Saint-Émilion, grand cru classé</i> <i>In original wooden case</i>					Château Figeac 2010 <i>Saint-Émilion, 1er grand cru classé</i> <i>In original wooden case</i>		
319	12 bottles			<i>per lot</i> HK\$8,500-13,000	328	6 bottles		<i>per lot</i> HK\$8,500-13,000
	Château Valandraud 2009 <i>Saint-Émilion, grand cru classé</i> <i>In original wooden case</i>					Mixed 2005 & 2006 Château Monbousquet		
320	12 bottles			<i>per lot</i> HK\$14,000-20,000		2005		(24)
	Mixed Formats of Château de Valandraud 2010					2006		(12)
	2010					<i>In original wooden cases</i>		
	2010				329	36 bottles		<i>per lot</i> HK\$15,000-22,000
	<i>In original wooden cases</i>					Mixed 2008 & 2011 Saint-Émilion		
321	3 magnums and 6 bottles			<i>per lot</i> HK\$14,000-20,000		Château Quinault L'Enclos 2008		(12)
	Mixed Formats of Virgine de Valandraud 2009 & 2010					Château Moulin Saint-Georges 2011		(12)
	2009					<i>In original wooden cases</i>		
	2010				330	24 bottles		<i>per lot</i> HK\$4,000-6,500
	2010					Mixed Formats of Château Troplong-Mondot 2010		
	<i>In original wooden cases</i>					2010		magnums (3)
322	3 magnums and 18 bottles			<i>per lot</i> HK\$8,000-13,000	331	3 magnums and 6 bottles		(6)
						<i>In original wooden cases</i>		
								<i>per lot</i> HK\$9,000-13,000

Château Angéus 2004

Saint-Émilion, 1er grand cru classé (A)
In original wooden case

332 12 bottles *per lot* HK\$19,000-28,000

Château Angéus 2005

Saint-Émilion, 1er grand cru classé (A)
In original wooden cases

333 12 bottles *per lot* HK\$28,000-42,000

334 12 "

Château Angéus 2006

Saint-Émilion, 1er grand cru classé (A)
In original wooden cases

335 12 bottles *per lot* HK\$20,000-30,000

336 12 "

Château Angéus 2009

Saint-Émilion, 1er grand cru classé (A)
In original wooden cases

337 12 bottles *per lot* HK\$24,000-35,000

338 12 "

2010 BORDEAUX VINTAGE REPORT

These are extremely impressive wines, strong and powerful, made from aggressive and extreme conditions of summer drought and heat that provided huge tannins as well as enormous potential alcohol and monumental ripeness of fruit. But, in addition to their raw power and tannin, they also have high acidity, imparted by the cool nights of August and September and resulting in the most unusual, possibly unique, combination of freshness as well as of power. This freshness differentiates them from the currently sleeker, softer 09's and led many at the outset to predict greater ageing potential. However recent tastings suggest that, although profoundly different from each other, these two vintages are now running neck-to-neck in ageability. Bill Blatch

2010 年波爾多年份報告

令人印象非常深刻的年份，在夏季乾旱酷熱的極端天氣產生大量單寧，酒精潛力優越，有豐富的成熟果味，造就剛勁有力的葡萄酒。但除了原始的勁度和單寧外，8月及9月清涼的夜晚亦令出品酸度偏高，最終出現可謂獨一無二的清新與勁度組合。這股清新氣息令此年份與較柔滑順口的2009年截然不同，令不少人初時預測此年份的陳年潛力會更佳。不過最近的品酒經驗顯示兩者雖然大異其趣，但陳年潛力卻是旗鼓相當。比爾·布拉齊

Château Angéus 2010

Saint-Émilion, 1er grand cru classé (A)
In original wooden case

339 3 magnums *per lot* HK\$11,000-17,000

Château Angéus 2010

Saint-Émilion, 1er grand cru classé (A)
In banded original wooden case

340 6 bottles *per lot* HK\$11,000-17,000

Château Angéus 2011

Saint-Émilion, 1er grand cru classé (A)
In banded original wooden case

341 12 bottles *per lot* HK\$17,000-24,000

Château Ausone

Another Right Bank property at the very top of the Saint-Émilion classification, Ausone has benefited from the famed consulting oenologist Michel Rolland since 1995. The vineyards east, south-east exposure protect the vines from the cool northerly winds and enable the grapes to reach optimal maturity. In 1997 the Vauthier family took full control of the estate and have invested considerable sums and energy into improvements, such as repairing the terrace walls, installing a new drainage system and replanting vines where necessary and are increasing the proportion of Cabernet Franc in the vineyards, which now stands at 55% with 45% Merlot.

歐頌酒莊

右岸的歐頌莊為聖艾美濃 (Saint-Émilion) 的頂級酒莊，1995年，知名釀酒師米歇爾·羅蘭 (Michel Rolland) 擔任顧問之後，酒莊更加聲名大噪。東和東南朝向的葡萄園保護葡萄藤免於嚴酷的北風的摧殘，確保果實達到最高成熟度。1997年沃提埃家族全面接管酒莊，投入了可觀的資金和精力對酒莊進行改進。

Château Ausone 2001

Saint-Émilion, 1er grand cru classé (A)
In original wooden cases

342 12 bottles *per lot* HK\$35,000-55,000

343 12 "

Château Ausone 2003

Saint-Émilion, 1er grand cru classé (A)
In original wooden case

344 12 bottles *per lot* HK\$65,000-95,000

Château Ausone 2004

Saint-Émilion, 1er grand cru classé (A)
In banded original wooden cases

345 18 bottles *per lot* HK\$48,000-70,000

Château Ausone 2006

Saint-Émilion, 1er grand cru classé (A)
In banded original wooden cases

346 9 bottles *per lot* HK\$26,000-40,000

Château Ausone 2006

Saint-Émilion, 1er grand cru classé (A)
In banded six-bottle original wooden cases

347 12 bottles *per lot* HK\$35,000-55,000

Château Ausone 2007

Saint-Émilion, 1er grand cru classé (A)
In banded original wooden cases

348 18 bottles *per lot* HK\$45,000-70,000

AUSONE



CHATEAU AUSONE

SAINT-ÉMILION

1^{ER} GRAND CRU CLASSÉ "A"

—→ 2009 ←—

FAMILLE VAUTHIER

Propriétaire

Lot 350

DEPOSE

Château Ausone 2008
Saint-Émilion, 1er grand cru classé (A)
In banded three-bottle original wooden case
 349 3 bottles *per lot* HK\$10,000-15,000

Château Ausone 2009
Saint-Émilion, 1er grand cru classé (A)
In six-bottle original wooden case
 350 6 bottles *per lot* HK\$32,000-48,000

Château Ausone 2010
Saint-Émilion, 1er grand cru classé (A)
In banded original wooden case
 351 3 magnums *per lot* HK\$32,000-48,000

Château Ausone 2010
Saint-Émilion, 1er grand cru classé (A)
In banded original wooden case
 352 6 bottles *per lot* HK\$32,000-48,000

Château Ausone 2011
Saint-Émilion, 1er grand cru classé (A)
In banded original wooden case
 353 6 bottles *per lot* HK\$15,000-22,000

La Chapelle d'Ausone 2008
Saint-Émilion
In six-bottle original wooden cases
 354 12 bottles *per lot* HK\$8,500-13,000

Château Cheval Blanc

Located in the commune of Saint-Émilion, but bordering on Pomerol, the estate consists of 39 hectares divided into forty-five plots. Each one is, to a certain extent, treated like a separate vineyard because of the differences in the age of the vines, grape variety, soil type, etc. The combination of these many facets accounts for Cheval Blanc's great complexity.

What makes Cheval Blanc so unusual is three main soil types – fine textured with clay, more coarsely textured with gravel, and large gravel with sand – that constitute a veritable patchwork. This singular terroir is made up primarily of clay and large-size gravel in certain plots and sandy soil with smaller gravel in other parts. Some estates in Saint-Émilion have excellent gravelly soil, while others in Saint-Émilion and Pomerol have very good clay soils. Cheval Blanc, on the other hand, is blessed with both types of soil in fairly equal proportions. The most is made of this natural advantage thanks to an original combination of grape varieties: 49% Cabernet Franc, 47% Merlot, and 4% Cabernet Sauvignon. Each plot has its own specific profile due to the age of the vines, surface area, kind of soil, type of rootstock and grape variety, etc. Therefore, it only follows that the wine produced from each plot has its own profile too. The ones from clay soil are powerful with velvety tannin, while the ones from gravel soil are more aromatic and elegant. A blend of both results in a wine that is both powerful and elegant with expressive aromatics as well as the complexity of the greatest wines.

Experiments have been conducted with every possible permutation of soil types and the three grape varieties. Soil temperatures were measured throughout the growing season in the context of this research, as well as the water supply and mineral absorption by the vines.

白馬酒莊

白馬酒莊坐落於聖艾米隆區，毗鄰波美侯產區。佔地 39 公頃的酒莊包括 45 片葡萄田，每一片葡萄田也以獨立的方式打理，因為葡萄樹樹齡、葡萄品種及土壤類別各有不同，造就複雜細緻的佳釀。

白馬酒莊的非凡佳釀，可歸因於三種特別的土壤：結構細密的黏土、粗糙的礫石土壤及砂石土壤，組合出理想的種植環境。這種獨特的風土主要包括結合大顆礫石的黏土園地，以及夾雜小礫石的砂質土壤。位於聖艾米隆區的部分酒莊皆擁有絕佳的礫土，其他位於聖艾米隆區及波美侯區的酒莊則擁有優質的黏土，而白馬酒莊則幸運地同時擁有這兩種土壤，而且比例平均。

酒莊種植的品麗珠、美樂及赤霞珠分別佔 49%、47% 及 4%，令莊園能善用天然的優勢。由於葡萄樹的樹齡、土地面積、土壤、根莖類別及葡萄品種各異，每一幅土地也擁有獨一無二的特性，而釀造的葡萄酒也帶有獨特的風味。黏土園地的出品剛勁，單寧柔滑細緻，而礫石園地的出品則較芳香優雅。將兩者混合後的珍釀既剛勁亦優雅，並呈現頂級美酒的馥郁與層次。

酒莊更不斷反覆試驗，組合各種土壤及三種葡萄。在葡萄的生長期，酒莊亦會記錄土壤溫度、供水量及葡萄吸收的礦物質。

Château Cheval-Blanc 1947
Saint-Émilion, 1er grand cru classé (A)
Corroded capsules, one damaged. Cruse & Fils slip labels, two damaged. Stained and slightly damaged labels. Levels one mid-shoulder, two low-shoulder
 355 3 bottles *per lot* HK\$95,000-220,000

Château Cheval-Blanc 1966
Saint-Émilion, 1er grand cru classé (A)
One slightly damaged capsule. Two US import slip labels. Slightly stained labels. Levels one base of neck, one top-shoulder, one upper-shoulder
 356 3 bottles *per lot* HK\$7,500-11,000

Château Cheval-Blanc 1982
Saint-Émilion, 1er grand cru classé (A)
In original wooden case. Good appearance. Levels base of neck
 357 11 bottles *per lot* HK\$55,000-85,000

Château Cheval-Blanc 2003
Saint-Émilion, 1er grand cru classé (A)
In original wooden case
 358 6 bottles *per lot* HK\$14,000-20,000

Château Cheval-Blanc 2004
Saint-Émilion, 1er grand cru classé (A)
In original wooden cases
 359 12 bottles *per lot* HK\$28,000-42,000
 360 12 "

Château Cheval-Blanc 2005*Saint-Émilion, 1er grand cru classé (A)
In original wooden case*361 6 bottles *per lot* HK\$24,000-35,000**Château Cheval-Blanc 2005***Saint-Émilion, 1er grand cru classé (A)
In original wooden case*362 12 bottles *per lot* HK\$48,000-75,000**Château Cheval-Blanc 2006***Saint-Émilion, 1er grand cru classé (A)
In original wooden case*363 12 bottles *per lot* HK\$28,000-42,000**Château Cheval-Blanc 2007***Saint-Émilion, 1er grand cru classé (A)
In original wooden case*364 12 bottles *per lot* HK\$28,000-42,000**Château Cheval-Blanc 2008***Saint-Émilion, 1er grand cru classé (A)
In original wooden case*365 11 bottles *per lot* HK\$26,000-38,000**Château Cheval-Blanc 2009***Saint-Émilion, 1er grand cru classé (A)
In six-bottle original wooden cases*366 12 bottles *per lot* HK\$48,000-75,000**Château Cheval-Blanc 2010***Saint-Émilion, 1er grand cru classé (A)
In original wooden case*367 3 magnums *per lot* HK\$26,000-40,000**Château Cheval-Blanc 2010***Saint-Émilion, 1er grand cru classé (A)
In three-magnum original wooden cases*368 6 magnums *per lot* HK\$55,000-80,000**Château Cheval-Blanc 2010***Saint-Émilion, 1er grand cru classé (A)
In original wooden case*369 6 bottles *per lot* HK\$26,000-40,000**Château Cheval-Blanc 2010***Saint-Émilion, 1er grand cru classé (A)
In six-bottle original wooden cases*370 12 bottles *per lot* HK\$55,000-80,000**Château Cheval-Blanc 2011***Saint-Émilion, 1er grand cru classé (A)
In six-bottle original wooden cases*371 12 bottles *per lot* HK\$28,000-42,000**Le Petit Cheval 2005***Saint-Émilion
In original wooden cases*372 24 bottles *per lot* HK\$20,000-30,000**Le Petit Cheval 2007***Saint-Émilion
In original wooden case*373 12 bottles *per lot* HK\$8,500-13,000

Lot 381

Mixed Formats of Le Petit Cheval 2010*In original wooden case* magnums (3)**2010***In six-bottle original wooden cases* (18)
374 3 magnums and 18 bottles *per lot* HK\$16,000-24,000**Le Petit Cheval 2011***Saint-Émilion**In six-bottle original wooden cases*
375 12 bottles *per lot* HK\$8,500-13,000**Château Bélair-Monange 2009***Saint-Émilion, 1er grand cru classé (B)**In banded six-bottle original wooden cases*
376 12 bottles *per lot* HK\$8,000-12,000**Château Le Tertre-Rôteboeuf 2009***Saint-Émilion, grand cru classé**In three-bottle original wooden cases*
377 18 bottles *per lot* HK\$16,000-24,000**Château Pavie 2005***Saint-Émilion, 1er grand cru classé**In original wooden case*
378 12 bottles *per lot* HK\$26,000-38,000**Château Pavie 2006***Saint-Émilion, 1er grand cru classé**In banded original wooden case*
379 12 bottles *per lot* HK\$17,000-24,000**2009 BORDEAUX VINTAGE REPORT**

Never before had Bordeaux reached such an extreme level of concentration. These are uncompromisingly thickly-built wines of enormous power and sumptuously ripe fruit and tannin. Yet it was not the hottest year (that was 2003), nor was it the driest (that was 2005). It was just the most perfect summer you could wish for, regularly hot and with just enough occasional light rain to keep the vines unstressed, so that they could develop their grapes regularly and seamlessly, going through the gears gently and culminating in a very hot, dry harvest. As for the 1982's and 1947's, which they closely resemble, they appeared very soft and silky at first. But all along we knew the tannins were there, just covered by the puppy fat, and they are now beginning to pack a big punch and to shut down for the long haul. So the jury now reconvenes to debate which is the more successful of the two vintages 2009 or 2010. Whatever conclusion; most 09's will have an extremely long window of ageability.
Bill Blatch

2009 年波爾多年份報告

過去從未出現過集中度如此高的波爾多紅酒。酒體非常厚實，勁度十足，果味和單寧成熟豐盈。這不是最炎熱的一年(2003年才是)，也不是最乾燥的一年(2005年才是)，只不過夏天氣候完美，不太熱，有驟雨，讓葡萄在無壓力的情況下順利結果，平穩度過各個階段，並在非常炎熱乾燥的天氣下收割。反觀天氣非常近似的1982年和1947年，兩者初時口感非常柔軟順滑，但卻留意到單寧的存在，只是被青澀味掩蓋，在現在卻開始變得非常突出，並會停止演變一段長時間，所以酒評家現在再度討論到底2009年還是2010年較佳。無論結論如何，肯定大部分2009年的出品也有極長的陳年時限。比爾·布拉齊

Château Pavie 2009*Saint-Émilion, 1er grand cru classé**In banded original wooden case*
380 12 bottles *per lot* HK\$20,000-30,000**Mixed 2005 & 2006 Clos de L'Oratoire****2005** (24)**2006** (12)*In original wooden cases*381 36 bottles *per lot* HK\$10,000-16,000**Château Canon 2006***Saint-Émilion, 1er grand cru classé**In original wooden cases*
382 48 bottles *per lot* HK\$17,000-24,000**Château Canon 2008***Saint-Émilion, 1er grand cru classé**In original wooden cases*
383 24 bottles *per lot* HK\$8,000-12,000**Château Canon 2009***Saint-Émilion, 1er grand cru classé**In original wooden case*
384 6 magnums *per lot* HK\$7,500-11,000**Château Canon 2009***Saint-Émilion, 1er grand cru classé**In original wooden cases*
385 36 bottles *per lot* HK\$22,000-35,000**Château Canon 2010***Saint-Émilion, 1er grand cru classé**In original wooden case*
386 6 magnums *per lot* HK\$7,500-11,000

Château Canon 2010
Saint-Émilion, 1er grand cru classé
In original wooden cases
 387 24 bottles *per lot* HK\$15,000-22,000

Mixed Formats of Château Canon 2011
2011 magnums (6)
2011 (12)
In original wooden cases
 388 6 magnums and 12 bottles *per lot* HK\$9,500-15,000

Château Canon-La-Gaffelière 2005
Saint-Émilion, grand cru classé
In original wooden cases
 389 24 bottles *per lot* HK\$12,000-18,000

Mixed 2009 Barsac
Château Climens 2009 (12)
Château Coutet 2009 (12)
In original wooden cases
 390 24 bottles *per lot* HK\$9,000-15,000

Mixed 2006 & 2010 Sauternes
Château Doisy-Védrines 2006 (12)
In original wooden case
Château Rieussec 2010 (12)
In six-bottle original wooden cases
 391 24 bottles *per lot* HK\$5,000-8,000

Château de Beaucastel, Châteauneuf-du-Pape 2000
Rhône, Perrin
In original wooden case
 392 12 bottles *per lot* HK\$4,200-6,500

J. L. Chave, Hermitage Blanc 2011
Rhône
In six-bottle original cartons
 393 12 bottles *per lot* HK\$11,000-16,000

J. L. Chave, Hermitage Blanc 2012
Rhône
In original carton
 394 6 bottles *per lot* HK\$7,000-10,000



J.L. Chave Hermitage Rouge 2003
Rhône
In original carton
 395 6 bottles *per lot* HK\$8,000-12,000

J.L. Chave Hermitage Rouge 2004
Rhône
 396 6 bottles *per lot* HK\$8,000-12,000

J.L. Chave Hermitage Rouge 2006
Rhône
 397 6 bottles *per lot* HK\$8,000-12,000

J.L. Chave Hermitage Rouge 2008
Rhône
In original carton
 398 12 bottles *per lot* HK\$9,000-14,000

J.L. Chave Hermitage Rouge 2010
Rhône
In original carton
 399 6 bottles *per lot* HK\$14,000-20,000

J.L. Chave Hermitage Rouge 2011
Rhône
In six-bottle original cartons
 400 12 bottles *per lot* HK\$15,000-22,000

J.L. Chave Hermitage Rouge 2012
Rhône
In original carton
 401 6 bottles *per lot* HK\$8,500-13,000

J.L. Chave Saint-Joseph 2011
Rhône
In original carton
 402 12 bottles *per lot* HK\$4,000-6,000

Mixed 2001 & 2003 Marc Sorrel
Hermitage Blanc Les Rocoules 2001
In original carton (12)
Crozes Hermitage Blanc 2003
In original carton. Slightly stained labels (12)
Hermitage Blanc 2003
In original carton. Slightly stained labels (12)
 403 36 bottles *per lot* HK\$10,000-15,000

Marc Sorrel, Hermitage Blanc Les Rocoules 2003
Rhône
In original cartons
 404 36 bottles *per lot* HK\$18,000-26,000

Paul Jaboulet Aîné, Hermitage La Chapelle 1961
Rhône
Slightly stained labels. Levels 2.5cms
 405 2 bottles *per lot* HK\$130,000-190,000

Paul Jaboulet Aîné, Hermitage La Chapelle 1961
Rhône
Slightly stained labels. Levels 2.5cms
 406 3 bottles *per lot* HK\$190,000-280,000

Paul Jaboulet Aîné, Hermitage La Chapelle 1990
Rhône
Integrated Singaporean import labels. Levels four 1.5cms, two 2cms
 407 6 bottles *per lot* HK\$18,000-26,000



Lots 405 & 406

Trimbach Gewürztraminer SGN 2000
 Alsace
In original carton. Signs of old seepage. Slightly stained labels
 408 12 bottles per lot HK\$8,000-12,000

Trimbach Pinot Gris SGN 1994
 Alsace
In original cartons
 409 24 bottles per lot HK\$11,000-16,000

Trimbach Pinot Gris SGN 2000
 Alsace
In original cartons
 410 24 bottles per lot HK\$11,000-16,000

Mixed 1997 & 2000 Trimbach Pinot Gris VT
1997 (12)
2000 (12)
In original cartons
 411 24 bottles per lot HK\$7,000-11,000

Domaine de la Romanée-Conti, Montrachet 1975
 Grand Cru, Côte de Beaune
Slightly depressed corks. Signs of old seepage. One slightly damaged capsule. J.L.P. Lebegue & Co. slip labels. Mature colour. Levels one 3.3cms, one 3.5cms, one 4.8cms
 412 3 bottles per lot HK\$55,000-85,000

Domaine de la Romanée-Conti, Montrachet 1984
 Grand Cru, Côte de Beaune
Slightly damaged Leroy slip label. Slightly stained and slightly damaged label. Mature colour. Level 2.5cms
 413 1 bottle per lot HK\$16,000-24,000

Domaine de la Romanée-Conti, Montrachet 1990
 Grand Cru, Côte de Beaune
Slightly discoloured capsules. Slightly stained labels. Mature colour. Levels one 2cms, one 3.5cms
 414 2 bottles per lot HK\$48,000-70,000

Domaine de la Romanée-Conti, Montrachet 1999
 Grand Cru, Côte de Beaune
Slightly damaged front and back label. Level 2cms
 415 1 bottle per lot HK\$24,000-38,000

Maison Albert Bichot, Vosne-Romanée 1er Cru Les Malconsorts Clos Frantin 2010
 Côte de Nuits
In six-bottle original cartons
 416 12 bottles per lot HK\$7,500-11,000

Mixed 2007, 2008 & 2013 Anne Gros, Bourgogne
2007 (12)
2008 (12)
2013 (12)
In six-bottle original cartons
 417 36 bottles per lot HK\$8,000-12,000

Mixed Anne Gros
Chambolle-Musigny La Combe d'Orveau 2007 (6)
Chambolle-Musigny La Combe d'Orveau 2009 (6)
Clos Vougeot Le Grand Maupertui 2009 (6)
Clos Vougeot Le Grand Maupertui 2013 (6)
In original cartons
 418 24 bottles per lot HK\$17,000-26,000



Lot 418

419	Anne Gros, Richebourg 2003 <i>Grand Cru, Côte de Nuits</i> <i>One slightly stained label</i> 2 bottles	<i>per lot</i> HK\$6,500-9,500	427	Comte Georges de Vogüé, Musigny VV 1990 <i>Grand Cru, Côte de Nuits</i> <i>Three slightly stained labels. Levels five 1cm, one 2cms</i> 6 bottles	<i>per lot</i> HK\$22,000-32,000
420	Anne Gros, Richebourg 2004 <i>Grand Cru, Côte de Nuits</i> <i>In six-bottle original carton</i> 3 bottles	<i>per lot</i> HK\$7,500-11,000	428	Mixed 2006 & 2009 Domaine Ponsot Morey-Saint-Denis 1er Cru Cuvée des Alouettes 2006 (6) Chambolle-Musigny Les Charmes 2009 (6) <i>In original wooden case</i> 12 bottles	<i>per lot</i> HK\$7,000-11,000
421	Anne Gros, Richebourg 2005 <i>Grand Cru, Côte de Nuits</i> <i>In original carton</i> 6 bottles	<i>per lot</i> HK\$30,000-45,000	429	Domaine Ponsot, Clos de la Roche VV 2004 <i>Grand Cru, Côte de Nuits</i> <i>Two slightly damaged labels</i> 6 bottles	<i>per lot</i> HK\$8,500-13,000
422	Anne Gros, Richebourg 2009 <i>Grand Cru, Côte de Nuits</i> 2 bottles	<i>per lot</i> HK\$7,500-11,000	430	Domaine Ponsot, Clos de la Roche VV 2005 <i>Grand Cru, Côte de Nuits</i> <i>In six-bottle original wooden cases</i> 12 bottles	<i>per lot</i> HK\$55,000-85,000
423	Anne Gros, Vosne-Romanée 1er Cru Les Barreaux 2013 <i>Côte de Nuits</i> <i>In original carton</i> 6 bottles	<i>per lot</i> HK\$4,000-6,000	431	Domaine Ponsot, Clos de la Roche VV 2006 <i>Grand Cru, Côte de Nuits</i> <i>Two slightly damaged labels</i> 6 bottles	<i>per lot</i> HK\$11,000-16,000
424	Armand Rousseau, Chambertin 1995 <i>Grand Cru, Côte de Nuits</i> <i>Levels 1cm</i> 2 bottles	<i>per lot</i> HK\$18,000-26,000	432	Domaine Ponsot, Clos de Vougeot VV 2005 <i>Grand Cru, Côte de Nuits</i> <i>Slightly damaged labels</i> 2 bottles	<i>per lot</i> HK\$4,200-6,500
425	Armand Rousseau, Chambertin 2000 <i>Grand Cru, Côte de Nuits</i> 4 bottles	<i>per lot</i> HK\$28,000-42,000	433	Domaine Ponsot, Grand Cru Assortment 2005 Clos Saint-Denis Cuvée du Centenaire (1) Clos de Vougeot VV (1) Clos de la Roche VV (1) Chapelle-Chambertin (1) Charmes-Chambertin Cuvée des Merles (1) Griotte-Chambertin (1) 6 bottles	<i>per lot</i> HK\$22,000-35,000
426	Armand Rousseau, Chambertin Clos-de-Bèze 1995 <i>Grand Cru, Côte de Nuits</i> <i>One slightly stained vintage neck label. Slightly stained labels.</i> <i>Levels 1cm</i> 2 bottles	<i>per lot</i> HK\$15,000-22,000			

Domaine Ponsot, Griotte-Chambertin 2004
Grand Cru, Côte de Nuits
 434 4 bottles per lot HK\$3,800-5,500

Domaine Ponsot, Griotte-Chambertin 2005
Grand Cru, Côte de Nuits
In original wooden case
 435 6 bottles per lot HK\$15,000-22,000

Domaine de la Romanée-Conti, Romanée-Conti 1988
Grand Cru, Côte de Nuits
One damaged capsule. One slightly damaged Leroy slip label. Levels one 1.5cms, two 2.8cms
 436 3 bottles per lot HK\$220,000-350,000

Domaine de la Romanée-Conti, Romanée-Conti 1989
Grand Cru, Côte de Nuits
Slightly stained label. Level 2cms
 437 1 bottle per lot HK\$75,000-110,000

Domaine de la Romanée-Conti, Romanée-Conti 1990
Grand Cru, Côte de Nuits
Slightly damaged label. Level 3.2cms
 438 1 bottle per lot HK\$110,000-160,000

Domaine de la Romanée-Conti, Romanée-Conti 1997
Grand Cru, Côte de Nuits
Levels one 1.5cms, one 2.5cms
 439 2 bottles per lot HK\$140,000-200,000

Domaine de la Romanée-Conti, Romanée-Conti 1998
Grand Cru, Côte de Nuits
 440 1 bottle per lot HK\$70,000-100,000

Domaine de la Romanée-Conti, Romanée-Conti 1999
Grand Cru, Côte de Nuits
 441 1 bottle per lot HK\$95,000-140,000

Domaine de la Romanée-Conti, Romanée-Conti 2002
Grand Cru, Côte de Nuits
One slightly damaged label
 442 2 bottles per lot HK\$160,000-240,000

Henri Mayer for Georges Mayer, Echézeaux 1994
Grand Cru, Côte de Nuits
Slightly stained label. Levels 1cm
 443 2 bottles per lot HK\$32,000-48,000

Henri Mayer for Georges Mayer, Echézeaux 1996
Grand Cru, Côte de Nuits
Level 0.5cm
 444 1 bottle per lot HK\$22,000-32,000

Henri Mayer for Georges Mayer, Echézeaux 1998
Grand Cru, Côte de Nuits
 445 1 bottle per lot HK\$15,000-22,000

Henri Mayer, Nuits-Saint-Georges Aux Meurgers 1987
Côte de Nuits
Corroded capsule. Slightly wrinkled label. Level 3cms
 446 1 bottle per lot HK\$13,000-19,000

Robert Groffier, Bonnes-Mares 2005
Grand Cru, Côte de Nuits
In original carton
 447 12 bottles per lot HK\$22,000-35,000





SOCIÉTÉ CIVILE DU DOMAINE DE LA ROMANÉE-CONTI
PROPRIÉTAIRE A VOSNE-ROMANÉE (COTE D'OR) FRANCE

ROMANÉE-CONTI
APPELLATION ROMANÉE-CONTI CONTRÔLÉE

4.814 Bouteilles Récoltées

BOUTEILLE N° 82261
ANNÉE 1997

Henri-Frédéric Roch
A. de V. & C. S.A.

Mise en bouteille au domaine



MONOPOLE
1997

SOCIÉTÉ CIVILE DU DOMAINE DE LA ROMANÉE-CONTI
PROPRIÉTAIRE A VOSNE-ROMANÉE (COTE D'OR) FRANCE

ROMANÉE-CONTI
APPELLATION ROMANÉE-CONTI CONTRÔLÉE

4.814 Bouteilles Récoltées

LES ASSOCIÉS-GÉRANTS
Henri-Frédéric Roch
A. de V. & C. S.A.

BOUTEILLE N° 03562
ANNÉE 1997

Mise en bouteille au domaine

Robert Groffier, Bonnes-Mares 2009
Grand Cru, Côte de Nuits
In original carton
 448 12 bottles *per lot* HK\$18,000-26,000

Robert Groffier, Bonnes-Mares 2010
Grand Cru, Côte de Nuits
In original carton
 449 12 bottles *per lot* HK\$17,000-24,000

Robert Groffier, Bonnes-Mares 2012
Grand Cru, Côte de Nuits
In original carton
 450 12 bottles *per lot* HK\$15,000-22,000

Robert Groffier, Bonnes-Mares 2013
Grand Cru, Côte de Nuits
In original carton
 451 12 bottles *per lot* HK\$14,000-20,000

Mixed 2007 & 2009 Robert Groffier, Chambertin Clos-de-Béze
2007 (3)
One slightly damaged label
2009 (12)
In original carton
 452 15 bottles *per lot* HK\$24,000-35,000

Robert Groffier, Chambertin Clos-de-Béze 2010
Grand Cru, Côte de Nuits
In original carton
 453 12 bottles *per lot* HK\$26,000-40,000

Robert Groffier, Chambertin Clos-de-Béze 2012
Grand Cru, Côte de Nuits
In original carton
 454 12 bottles *per lot* HK\$17,000-24,000

Robert Groffier, Chambertin Clos-de-Béze 2013
Grand Cru, Côte de Nuits
In original carton
 455 6 bottles *per lot* HK\$9,000-13,000

Mixed 2007 & 2008 Robert Groffier, Chambolle-Musigny 1er Cru Les Amoureuses
2007 (2)
Slightly damaged labels
2008 (2)
 456 4 bottles *per lot* HK\$5,000-8,500

Robert Groffier, Chambolle-Musigny 1er Cru Les Amoureuses 2009
1er Cru, Côte de Nuits
In original carton
 457 12 bottles *per lot* HK\$20,000-32,000

Robert Groffier, Chambolle-Musigny 1er Cru Les Amoureuses 2010
1er Cru, Côte de Nuits
In original carton
 458 12 bottles *per lot* HK\$22,000-32,000

Robert Groffier, Chambolle-Musigny 1er Cru Les Amoureuses 2012
1er Cru, Côte de Nuits
In original carton
 459 12 bottles *per lot* HK\$16,000-24,000

Robert Groffier, Chambolle-Musigny 1er Cru Les Amoureuses 2013
1er Cru, Côte de Nuits
In original carton
 460 12 bottles *per lot* HK\$13,000-19,000

Mixed 2005, 2012 & 2013 Robert Groffier, Chambolle-Musigny 1er Cru Les Hauts Doix
2005 (3)
2012 (12)
In original carton
2013 (12)
In original carton
 461 27 bottles *per lot* HK\$17,000-24,000

Robert Groffier, Chambolle-Musigny 1er Cru Les Sentiers 2004
1er Cru, Côte de Nuits
 462 6 bottles *per lot* HK\$4,000-6,000

Robert Groffier, Chambolle-Musigny 1er Cru Les Sentiers 2007
1er Cru, Côte de Nuits
In original carton
 463 12 bottles *per lot* HK\$8,000-12,000

Robert Groffier, Chambolle-Musigny 1er Cru Les Sentiers 2008
1er Cru, Côte de Nuits
In original carton
 464 12 bottles *per lot* HK\$7,000-10,000

Robert Groffier, Chambolle-Musigny 1er Cru Les Sentiers 2009
1er Cru, Côte de Nuits
In original carton
 465 12 bottles *per lot* HK\$8,500-13,000

Robert Groffier, Chambolle-Musigny 1er Cru Les Sentiers 2010
1er Cru, Côte de Nuits
In original carton
 466 12 bottles *per lot* HK\$11,000-16,000

Robert Groffier, Chambolle-Musigny 1er Cru Les Sentiers 2012
1er Cru, Côte de Nuits
In original carton
 467 12 bottles *per lot* HK\$7,500-11,000

Robert Groffier, Chambolle-Musigny 1er Cru Les Sentiers 2013
1er Cru, Côte de Nuits
In original carton
 468 12 bottles *per lot* HK\$6,000-9,000

Mixed 2000s Robert Groffier

Gevrey-Chambertin 1er Cru Les Seuvrées 2010
In original carton (12)
Gevrey-Chambertin 2004 (6)
Gevrey-Chambertin 2008 (6)
Gevrey-Chambertin 2009
In original carton (12)
 469 36 bottles *per lot* HK\$12,000-17,000

Domaine Michel Lafarge, Pommard 1er Cru Les Pézerolles 2005

Pommard
 470 6 bottles *per lot* HK\$4,500-7,000

Mixed 2000s Fritz Haag Brauneberger Juffer Sonnenuhr Riesling

Auslese Goldkapsel 2003
In original carton (6)
Auslese Goldkapsel 2006
In original carton (12)
Spätlese 2005
In original carton (12)
Spätlese 2006
In original carton (12)
 471 42 bottles *per lot* HK\$13,000-20,000

Mixed Formats of 2000s Germany Riesling

Diel Goldloch Riesling Kabinett 2008
In six-bottle original cartons (18)
Diel Goldloch Riesling Spätlese 2005
In original carton (12)
Diel Pittermännchen Riesling Spätlese 2005
In original carton. Signs of old seepage magnums (6)
Diel Pittermännchen Riesling Spätlese 2008
In six-bottle original cartons (24)
 472 6 magnums and 54 bottles *per lot* HK\$15,000-24,000

Mixed 2004 & 2005 Clos Figueres

2004 (12)
2005 (12)
In six-bottle original wooden cases
 473 24 bottles *per lot* HK\$8,500-14,000

Mixed 2005, 2009 & 2012 Clos Mogador 2005

In six-bottle original wooden cases (12)

2009

In six-bottle original wooden cases (12)

2012

In six-bottle original cartons (12)

474 36 bottles *per lot* HK\$18,000-28,000

Mixed 2008 Clos Mogador & Manyetes

Clos Mogador 2008

(12)

Manyetes 2008

(12)

In six-bottle original wooden cases

475 24 bottles *per lot* HK\$8,000-12,000

Espectacle del Montsant 2005

Spain

In original carton

476 12 bottles *per lot* HK\$8,500-13,000



Lot 471

Index by Vintage

WINE	Lot No.	WINE	Lot No.
BORDEAUX WHITE		Petrus	288
2003		1998	
Pavillon Blanc du Château Margaux	171	Petrus	289
2004		2000	
Pavillon Blanc du Château Margaux	172	Château Lafite-Rothschild	21
2005		Château Margaux	148
Pavillon Blanc du Château Margaux	173	2001	
2008		Château Lafite-Rothschild	22-23
Pavillon Blanc du Château Margaux	174	Château Ausone	342-343
2009		2002	
Pavillon Blanc du Château Margaux	175	Château Lafite-Rothschild	24-26
Château Latour-Martillac Blanc	255	Carruades de Lafite-Rothschild	49
Château Pape-Clément Blanc	262	Petrus	290-291
MIXED		2003	
Mixed 2010 & 2011 Pavillon Blanc du Château Margaux	176	Château Lafite-Rothschild	27-28
Mixed Formats of Château Pape-Clément Blanc 2010	263	Carruades de Lafite-Rothschild	50
Mixed Formats of Domaine de Chevalier Blanc 2010 & 2011	266	Château Mouton-Rothschild	86
Mixed 2009 Barsac	390	Château Margaux	149
Mixed 2006 & 2010 Sauternes	391	Château La Mission-Haut-Brion	236
BORDEAUX RED		Petrus	292
1947		Château Ausone	344
Château Cheval-Blanc	355	Château Cheval-Blanc	358
1953		2004	
Château Mouton-Rothschild	82	Château Cos d'Estournel	1
1961		Château Lafite-Rothschild	29-31
Château Lafite-Rothschild	18	Carruades de Lafite-Rothschild	51-54
Château Latour	59	Château Latour	65
Château Mouton-Rothschild	83	Les Forts de Latour	77
Château La Mission-Haut-Brion	233	Château Margaux	150
1966		Pavillon Rouge du Château Margaux	177-179
Château Palmer	202	Château Palmer	203
Château Figeac	323	Château Haut-Brion	215
Château Cheval-Blanc	356	Château La Mission-Haut-Brion	237
1970		Château Lafleur	270-271
Château Latour	60	Les Pensées de Lafleur	274
1975		Le Pin	293
Château Lafleur	268	Vieux-Château-Certan	300-301
Petrus	285	Château Angélu	332
1982		Château Ausone	345
Château Latour	61	Château Cheval-Blanc	359-360
Château Mouton-Rothschild	84	2005	
Château Pichon-Longueville, Lalande	99	Château Cos d'Estournel	2
Château Ducru-Beaucaillou	113	Château Montrose	15
Château Léoville-Las-Cases	125	Château Lafite-Rothschild	32-33
Château Margaux	145	Carruades de Lafite-Rothschild	55
Château Haut-Brion	213	Château Latour	66-67
Château La Mission-Haut-Brion	234	Les Forts de Latour	78
Château Lafleur	269	Château Duhart-Milon	106
Petrus	286	Château Léoville-Las-Cases	126
Château Cheval-Blanc	357	Château Margaux	151-153
1983		Pavillon Rouge du Château Margaux	180
Château Margaux	146	Château Palmer	204
1985		Château Haut-Brion	216
Petrus	287	Le Bahans du Haut-Brion	225
1986		Château La Mission-Haut-Brion	238-240
Château Lafite-Rothschild	19	Château Haut-Bailly	256-258
Château Latour	62	Clos L'Église	284
Château Mouton-Rothschild	85	Le Pin	294
Château Pichon-Longueville, Lalande	100	Vieux-Château-Certan	302
Château La Mission-Haut-Brion	235	Château de Valandraud	316
1989		Château Angélu	333-334
Château Lafite-Rothschild	20	Château Cheval-Blanc	361-362
Château Latour	63	Le Petit Cheval	372
Château Margaux	147	Château Pavie	378
Château Haut-Brion	214	Château Canon La Gaffelière	389

Index by Vintage

WINE	Lot No.	WINE	Lot No.
2006		Vieux-Château-Certan	306-307
Château Cos d'Estournel	3	Château de Valandraud	319
Château Calon-Ségur	17	Château Figeac	326
Château Lafite-Rothschild	34-38	Château Ausone	349
Carruades de Lafite-Rothschild	56	La Chapelle d'Ausone	354
Château Latour	68-69	Château Cheval-Blanc	365
Château Mouton-Rothschild	87-88	Château Canon	383
Château Duhart-Milon	107	2009	
Château Ducru-Beaucaillou	114	Château Cos d'Estournel	7
Château Léoville-Las-Cases	127-128	Château Lafite-Rothschild	44-45
Château Margaux	154-155	Château Latour	74
Pavillon Rouge du Château Margaux	181	Château Mouton-Rothschild	92-94
Château Rauzan-Ségla	189-190	Château Pichon-Longueville, Baron	98
Château Palmer	205-206	Château Ducru-Beaucaillou	116
Château Haut-Brion	217	Château Léoville-Barton	119-121
Le Bahans du Haut-Brion	226	Château Léoville-Las-Cases	131
Château La Mission-Haut-Brion	241-242	Clos du Marquis	133
Château Lafleur	272	Château Langoa-Barton	137-138
Château L'Évangile	279	Château Margaux	161-162
Le Pin	295	Pavillon Rouge du Château Margaux	184-185
Vieux-Château-Certan	303-304	Château Rauzan-Ségla	194-195
Château de Valandraud	317	Alter Ego de Palmer	211
Château Figeac	324	Château d'Issan	212
Château Angélu	335-336	Château Haut-Brion	221
Château Ausone	346-347	Le Clarence de Haut-Brion	229-231
Château Cheval-Blanc	363	Château La Mission-Haut-Brion	249-250
Château Pavie	379	Château Pape-Clément	264
Château Canon	382	Château L'Église-Clinet	278
2007		Le Pin	298
Château Cos d'Estournel	4-5	Vieux-Château-Certan	308
Château Lafite-Rothschild	39-40	Château La Fleur de Bouïard	312
Carruades de Lafite-Rothschild	57	Château La Fleur de Bouïard Le Plus	314
Château Latour	70-71	Château de Valandraud	320
Château Mouton-Rothschild	89	Château Figeac	327
Château Léoville-Las-Cases	129	Château Angélu	337-338
Château Margaux	156-157	Château Ausone	350
Château Rauzan-Ségla	191-192	Château Cheval-Blanc	366
Château Haut-Brion	218-219	Château Bélaïr-Monange	376
Château La Mission-Haut-Brion	243-244	Château Le Tertre-Rôteboeuf	377
Château Lafleur	273	Château Pavie	380
Château L'Église-Clinet	276	Château Canon	384-385
Le Pin	296	2010	
Vieux-Château-Certan	305	Château Cos d'Estournel	8-10
Château de Valandraud	318	Château Montrose	16
Château Figeac	325	Château Lafite-Rothschild	46-47
Château Ausone	348	Château Latour	75
Château Cheval-Blanc	364	Château Léoville-Barton	122-123
Le Petit Cheval	373	Château Langoa-Barton	140
2008		Château Margaux	163-168
Château Cos d'Estournel	6	Pavillon Rouge du Château Margaux	187
Château Lafite-Rothschild	41-43	Château Rauzan-Ségla	196-199
Carruades de Lafite-Rothschild	58	Château Palmer	208-209
Château Latour	72-73	Château Haut-Brion	222-223
Les Forts de Latour	79	Château La Mission-Haut-Brion	251-253
Château Mouton-Rothschild	90-91	Château L'Évangile	280
Château Léoville-Las-Cases	130	Le Pin	299
Château Margaux	158-160	Vieux-Château-Certan	309
Pavillon Rouge du Château Margaux	182-183	Château La Fleur de Bouïard	313
Château Rauzan-Ségla	193	Château La Fleur de Bouïard Le Plus	315
Château Palmer	207	Château Figeac	328
Château Haut-Brion	220	Château Angélu	339-340
Le Clarence de Haut-Brion	227-228	Château Ausone	351-352
Château La Mission-Haut-Brion	245-248	Château Cheval-Blanc	367-370
Château Haut-Bailly	259	Château Canon	386-387
Château L'Église-Clinet	277	2011	
Le Pin	297	Château Lafite-Rothschild	48

Index by Vintage

WINE	Lot No.	WINE	Lot No.
Château Latour	76	Mixed 2005 & 2006 Clos de L'Oratoire	381
Les Forts de Latour	81	Mixed Formats of Château Canon 2011	388
Château Margaux	169-170	BURGUNDY WHITE	
Pavillon Rouge du Château Margaux	188	1975	
Château Rauzan-Ségla	200-201	Domaine de la Romanée-Conti, Montrachet	412
Château Palmer	210	1984	
Château Haut-Brion	224	Domaine de la Romanée-Conti, Montrachet	413
Vieux-Château-Certan	310	1990	
Château Angélys	341	Domaine de la Romanée-Conti, Montrachet	414
Château Ausone	353	1999	
Château Cheval-Blanc	371	Domaine de la Romanée-Conti, Montrachet	415
Le Petit Cheval	375	BURGUNDY RED	
2014		1987	
Vieux-Château-Certan	311	Henri Jayer, Nuits-Saint-Georges Aux Meurgers	446
MIXED		1988	
Mixed Formats of Château Cos d'Estournel 2011	11	Domaine de la Romanée-Conti, Romanée-Conti	436
Mixed 2006 & 2008 Les Pagodes de Cos	12	1989	
Mixed 2009 & 2010 Les Pagodes de Cos	13	Domaine de la Romanée-Conti, Romanée-Conti	437
Mixed 2003 Château Montrose & La Dame de Montrose	14	1990	
Mixed 1990 & 1992 Château Latour	64	Comte Georges de Vogüé, Musigny VV	427
Mixed Formats of Les Forts de Latour 2010	80	Domaine de la Romanée-Conti, Romanée-Conti	438
Mixed Formats of Château Mouton-Rothschild 2010	95	1994	
Mixed Formats of Château Mouton-Rothschild 2011	96	Georges Jayer, Echézeaux	443
Mixed 2005 & 2006 Château Pichon-Longueville, Baron	97	1995	
Mixed 2005 & 2006 Château Pichon-Longueville, Lalande	101	Armand Rousseau, Chambertin	424
Mixed 2007-2009 Château Pichon-Longueville, Lalande	102	Armand Rousseau, Chambertin Clos-de-Bèze	426
Mixed 2010 & 2011 Château Pichon-Longueville, Lalande in Magnums	103	1996	
Mixed 2010 & 2011 Château Pichon-Longueville, Lalande	104	Georges Jayer, Echézeaux	444
Mixed 2010 & 2011 Château Pichon-Longueville, Lalande Réserve de la Comtesse	105	1997	
Mixed 2007 & 2008 Château Duhart-Milon	108	Domaine de la Romanée-Conti, Romanée-Conti	439
Mixed 2009 & 2010 Château Duhart-Milon	109	1998	
Mixed 2006 & 2008 Château Clerc-Milon	110	Domaine de la Romanée-Conti, Romanée-Conti	440
Mixed Formats of Château Clerc-Milon 2009 & 2010	111	Georges Jayer, Echézeaux	445
Mixed Formats of Château Pontet-Canet 2010	112	1999	
Mixed 2007 & 2008 Château Ducru-Beaucaillou	115	Domaine de la Romanée-Conti, Romanée-Conti	441
Mixed 2009 Château Ducru-Beaucaillou & La Croix de Beaucaillou	117	2000	
Mixed Formats of Château Ducru-Beaucaillou 2010	118	Armand Rousseau, Chambertin	425
Mixed Formats of Château Léoville-Barton 2011	124	2002	
Mixed Formats of Château Léoville-Las-Cases 2010	132	Domaine de la Romanée-Conti, Romanée-Conti	442
Mixed Formats of Clos du Marquis 2010	134	2003	
Mixed Formats of Château Léoville-Poyferré 2010	135	Anne Gros, Richebourg	419
Mixed 2006 & 2007 Château Langoa-Barton	136	2004	
Mixed Formats of Château Langoa-Barton 2010	139	Anne Gros, Richebourg	420
Mixed Formats of Château Langoa-Barton 2011	141	Domaine Ponsot, Clos de la Roche VV	429
Mixed Formats of Haut-Médoc 2006 & 2010	142	Domaine Ponsot, Griotte-Chambertin	434
Mixed 1953 & 1955 Château Margaux	143	Robert Groffier, Chambolle-Musigny 1er Cru Les Sentiers	462
Mixed 1961 & 1966 Château Margaux	144	2005	
Mixed Formats of Pavillon Rouge du Château Margaux 2010	186	Anne Gros, Richebourg	421
Mixed Formats of Le Clarence de Haut-Brion 2010	232	Domaine Ponsot, Clos de la Roche VV	430
Mixed Formats of Château La Mission-Haut-Brion 2011	254	Domaine Ponsot, Clos de Vougeot VV	432
Mixed 2010 & 2011 Château Haut-Bailly in Magnums	260	Domaine Ponsot, Griotte-Chambertin	435
Mixed 2010 & 2011 Château Haut-Bailly	261	Robert Groffier, Bonnes-Mares	447
Mixed Formats of Château Pape-Clément 2010	265	Domaine Michel Lafarge, Pommard 1er Cru Les Pèzerolles	470
Mixed Formats of Domaine de Chevalier 2010	267	2006	
Mixed 2006 Château L'Église-Clinet & La Petite Église	275	Domaine Ponsot, Clos de la Roche VV	431
Mixed 2006 & 2009 Pomerol	281	2007	
Mixed 1959 & 1970 Château Trotanoy	282	Robert Groffier, Chambolle-Musigny 1er Cru Les Sentiers	463
Mixed 2004 & 2006 Château Trotanoy	283	2008	
Mixed Formats of Château de Valandraud 2010	321	Robert Groffier, Chambolle-Musigny 1er Cru Les Sentiers	464
Mixed Formats of Virgine de Valandraud 2009 & 2010	322	2009	
Mixed 2005 & 2006 Château Monbousquet	329	Anne Gros, Richebourg	422
Mixed 2008 & 2011 Saint-Émilion	330	Robert Groffier, Bonnes-Mares	448
Mixed Formats of Château Troplong-Mondot 2010	331	Robert Groffier, Chambolle-Musigny 1er Cru Les Amoureuses	457
Mixed Formats of Le Petit Cheval 2010	374	Robert Groffier, Chambolle-Musigny 1er Cru Les Sentiers	465

Index by Vintage

WINE	Lot No.	WINE	Lot No.
2010		2000	
Maison Albert Bichot, Vosne-Romanée 1er Cru Les Malconsorts Clos Frantin	416	Trimbach Gewürztraminer SGN	408
Robert Groffier, Bonnes-Mares	449	Trimbach Pinot Gris SGN	410
Robert Groffier, Chambertin Clos-de-Béze	453	MIXED	
Robert Groffier, Chambolle-Musigny 1er Cru Les Amoureuses	458	Mixed 1997 & 2000 Trimbach Pinot Gris VT	411
Robert Groffier, Chambolle-Musigny 1er Cru Les Sentiers	466	SPAIN	
2012		2005	
Robert Groffier, Bonnes-Mares	450	Espectacle del Montsant	476
Robert Groffier, Chambertin Clos-de-Béze	454	GERMANY	
Robert Groffier, Chambolle-Musigny 1er Cru Les Amoureuses	459	MIXED	
Robert Groffier, Chambolle-Musigny 1er Cru Les Sentiers	467	Mixed 2000s Fritz Haag Riesling	471
2013		Mixed Formats of 2000s Germany Riesling	472
Anne Gros, Vosne-Romanée 1er Cru Les Barreaux	423		
Robert Groffier, Bonnes-Mares	451		
Robert Groffier, Chambertin Clos-de-Béze	455		
Robert Groffier, Chambolle-Musigny 1er Cru Les Amoureuses	460		
Robert Groffier, Chambolle-Musigny 1er Cru Les Sentiers	468		
MIXED			
Domaine Ponsot, Grand Cru Assortment 2005	433		
Mixed 2007, 2008 & 2013 Anne Gros, Bourgogne	417		
Mixed Anne Gros	418		
Mixed 2006 & 2009 Domaine Ponsot	428		
Mixed 2007 & 2009 Robert Groffier, Chambertin Clos-de-Béze	452		
Mixed 2007 & 2008 Robert Groffier, Chambolle-Musigny 1er Cru Les Amoureuses	456		
Mixed 2005, 2012 & 2013 Robert Groffier, Chambolle-Musigny 1er Cru Les Hauts Doix	461		
Mixed 2000s Robert Groffier	469		
RHÔNE WHITE			
2003			
Marc Sorrel, Hermitage Blanc Les Rocoules	404		
2011			
J.L. Chave Hermitage Blanc	393		
2012			
J.L. Chave Hermitage Blanc	394		
MIXED			
Mixed 2001 & 2003 Marc Sorrel	403		
RHÔNE RED			
1961			
Paul Jaboulet Aîné, Hermitage La Chapelle	405-406		
1990			
Paul Jaboulet Aîné, Hermitage La Chapelle	407		
2000			
Château de Beaucastel, Châteauneuf-du-Pape	392		
2003			
J.L. Chave Hermitage Rouge	395		
2004			
J.L. Chave Hermitage Rouge	396		
2006			
J.L. Chave Hermitage Rouge	397		
2008			
J.L. Chave Hermitage Rouge	398		
2010			
J.L. Chave Hermitage Rouge	399		
2011			
J.L. Chave Hermitage Rouge	400		
J.L. Chave Saint-Joseph	402		
2012			
J.L. Chave Hermitage Rouge	401		
ALSACE			
1994			
Trimbach Pinot Gris SGN	409		

FINE AND RARE WINES
ESTEEMED CONNOISSEUR MR YAP CHEE MENG'S
PRIVATE COLLECTION PART II

佳士得名釀

Hong Kong 9 September 2017 | 香港 2017年9月9日



CHRISTIE'S 佳士得

SERVICES · 服務

WRITTEN AND TELEPHONE BIDS & CHRISTIE'S LIVE

書面和電話競投及佳士得實時競投服務

Tel 電話：+852 2978 9910

Email 電郵：bidsasia@christies.com

PADDLE REGISTRATION

競投牌登記

Tel 電話：+852 2760 1766

Email 電郵：registrationasia@christies.com

CATALOGUES ONLINE 網上拍賣目錄

Lotfinder®

Internet 網站：www.christies.com

CLIENT SERVICES 客戶服務

Tel 電話：+852 2760 1766

Email 電郵：infoasia@christies.com

POST-SALE SERVICES 售後服務

Tel 電話：+852 2760 1766

Email 電郵：postsaleasia@christies.com

ENQUIRIES · 查詢

HK 香港：+852 2760 1766

UK 英國：+44 (0)20 7627 2707

US 美國：+1 212 703 8080

Internet 網站：www.christies.com

We may convert and display in our catalogues the HK\$ **estimates** in US\$. This is for the convenience of our clients only and is not binding in any way. The rate of exchange is fixed at the latest practical date prior to the printing of the catalogue and may change by the time of the sale.

我們可將港元**估價**轉換成美元並於目錄中顯示。這僅為方便我們的客戶而不具有任何法律約束力。該貨幣兌換率是根據最貼近目錄付印時的兌換率設定，所以可能與拍賣當日兌換率有差別。

FINE AND RARE WINES: ESTEEMED CONNOISSEUR MR YAP CHEE MENG'S PRIVATE COLLECTION PART II 佳士得名釀

SATURDAY 9 SEPTEMBER 2017
2017年9月9日(星期六)

AUCTION · 拍賣

Saturday 9 September · 9月9日(星期六)

11.00am (Lots 477-870) · 上午11.00 (拍賣品編號477-870)

Location: The James Christie Room, 22nd Floor, Alexandra House,

18 Chater Road, Central, Hong Kong

地點：香港中環遮打道18號歷山大廈22樓佳士得藝廊

Tel 電話：+852 2760 1766 · Fax 傳真：+852 2760 1767

AUCTION CODE AND NUMBER · 拍賣名稱及編號

In sending Written and Telephone bids or making enquiries, this sale should be referred to as **SING-14719**

在遞交書面和電話競投表格或查詢拍賣詳情時，請註明拍賣名稱及編號為 **SING-14719**。

CONDITIONS OF SALE · BUYING AT CHRISTIE'S

業務規定 · 買家須知

This auction is subject to Important Notices and Explanation of Cataloguing Practice, Conditions of Sale · Buying at Christie's and reserves of the lots.

此次拍賣受限於重要通知及目錄編列方法之說明、業務規定、買方須知及拍品底價。

SALE CO-ORDINATOR · 拍賣統籌

Joyce Cheung

Tel 電話：+852 2978 6763

EMAIL · 電郵

For general enquiries about this auction, emails should be addressed to the Sale Co-ordinator(s) at wineauction@christies.com

如對此拍賣有任何查詢，可與佳士得拍賣統籌聯絡。

電郵地址：wineauction@christies.com

AUCTIONEERS · 拍賣官

David Elswood

Simon Tam

CHRISTIE'S LIVE
Bid live in Christie's salerooms worldwide

christies.com

CHRISTIE'S 佳士得

**FINE AND RARE WINES:
ESTEEMED CONNOISSEUR
MR YAP CHEE MENG'S
PRIVATE COLLECTION PART II**
佳士得名釀

SATURDAY 9 SEPTEMBER 2017

11.00am

Lots 477-870

Sale 14719

9月9日(星期六)

上午十一時正

(拍品 477 至 870)

編號 14719

The James Christie Room, 22nd Floor, Alexandra House,

18 Chater Road, Central, Hong Kong

香港中環遮打道 18 號歷山大廈 22 樓佳士得藝廊

Please note that parcel bidding will be offered throughout Sale 14719.

請注意，本場拍賣(編號 14719)部份拍品將以組合形式推出。成功投得每個組合第一款拍品的買家，可選擇以同一價格購買餘下所有或部份拍品。

**FINE AND RARE WINES:
ESTEEMED CONNOISSEUR MR YAP CHEE MENG'S PRIVATE COLLECTION PART II**

Welcome to Christie's Fine & Rare Wines Auction.

This is a fabulous single-owner collection from retired Chartered Accountant and former KPMG Asia Pacific Chief Operating Officer, Mr Yap Chee Meng who has been an avid collector of fine wines for the past thirty years. You will find some of the most desirable Burgundy and Bordeaux from well-known producers in the sale, including those which are made in very limited quantities such as DRC's Grand Crus, Chambertins from Rousseau, Musigny from Roumier, Faiveley, Jadot and J.F. Mugnier, Liger-Belair, Montrachet from Lafon, Le Pin, Ausone, and Haut Brion. All the Bordeaux First Growths are represented. There are also cult wines from the Rhône, Australia, Spain and USA as well as highly sought-after bottles from Champagne and Italy.

The majority of the wines were acquired directly from the producers or their respective wine agents. Many of the wines are released on miniscule allocations and over his years of collecting, Mr Yap has managed to amass an impressively large collection that is incredibly hard to find in the world of Finest & Rarest wines. The wines were all stored either in professional storage in the UK or Singapore's world class storage facility, WineBond from initial release until shipment to Hong Kong specifically for this sale. The provenance of this single-owner collection is unparalleled and the conditions are generally excellent; for example many of the original cartons from ten to fifteen years ago are still in pristine condition.

Mr Yap commented that "Wine is a passion and I am careful about provenance. I don't think I can stop collecting. This sale will allow me to continue to do so and at the same time, offer fellow collectors accessibility to some interesting bottles which they can share with friends".

Simon Tam

Head of Wine, Asia

佳士得名釀

歡迎參加佳士得名釀拍賣。

這批出類拔萃的單一藏家窖藏由退休特許會計師兼前畢馬威亞太區首席營運總監葉志明先生所有，匯聚他三十年來精心蒐羅的各地名莊珍品，包括多款夢寐以求的勃艮第及波爾多莊園名釀，例如羅曼尼康帝莊特級葡萄園、盧梭莊香貝丹、盧米莊慕西尼、法維萊莊、路易亞都莊、木尼艾莊、里格貝拉莊、拉芳莊蒙哈榭、里鵬莊、奧松莊及侯伯王莊等，波爾多所有一級莊園盡皆網羅。另外，亦有較鮮為人知的隆河區、澳洲、西班牙及美國傳奇珍釀，以及香檳區及意大利等地的臻品，精采紛呈。

葉先生的窖藏大多直接購自各大莊園或葡萄酒代理，當中包括多瓶限量釀造之美酒，全部皆為難得一見的頂級珍釀，見證藏家多年的心血結晶。這批美酒一直貯存在英國的專業酒窖或新加坡的世界級窖藏公司 WineBond，並在拍賣前直送抵港。這批私人窖藏珍藏皆來源有緒、品相出眾，多箱原裝佳釀已陳年10至15年，但狀態依然絕佳。

葉先生表示：「我熱愛葡萄酒，對來源一絲不苟。我對收藏美酒的熱情不會冷卻，是次拍賣讓我可以繼續蒐求珍品，同時為其他藏家帶來購藏、與親友共享特色佳釀的機會。」

譚業明

佳士得亞洲區名酒部主管

SATURDAY 9 SEPTEMBER · 11.00AM

Lots 477-870

FINE AND RARE WINES:

ESTEEMED CONNOISSEUR MR YAP CHEE MENG'S PRIVATE COLLECTION PART II

佳士得名釀

Mixed Henri Giraud

Fût de Chêne 1998

In banded original wooden case

(6)

Hommage François Hemart NV

(5)

477 11 bottles

per lot HK\$11,000-16,000

Domaine Jacques Selosse

In 1949 Jacques Selosse, Anselme's father, created in Avize the Domaine, which still bears his name, with his wife. Anselme took over the estate in 1974.

Domaine Jacques Selosse produces 57,000 bottles of Champagne every year from grapes grown and harvested on 7.5 hectares of vines spread over Chardonnay plots in the Côte de Blancs — Avize, Cramant, Oger, Le Mesnil-sur-Oger — and a few Montagne de Reims plots, dedicated to growing Pinot Noir, in Aÿ, Ambonny and Mareuil-sur-Aÿ.

雅克·塞羅斯酒莊

1949年，安塞姆的父親雅克·塞羅斯與母親在阿維茲村創立酒莊，此酒莊至今仍以其父命名。安塞姆於1974年接掌莊園。

雅克·塞羅斯酒莊每年出產57,000瓶香檳，專門種植霞多麗的葡萄田佔地7.5公頃，分佈於白丘地區的阿維茲村、科哈蒙村、歐吉村和梅尼爾-歐吉村，而位於蘭斯山丘地區的阿依村、安邦內存和瑪瑚-阿依村的數塊田地則主要栽種黑皮諾。

Jacques Selosse Brut Initial NV

Avize

In six-bottle original cartons

478 12 bottles

per lot HK\$12,000-19,000

Jacques Selosse, Sous le Mont NV

Avize

In original wooden case

479 6 bottles

per lot HK\$11,000-16,000

Jacques Selosse, Substance NV

Avize

In six-bottle original cartons

480 12 bottles

per lot HK\$18,000-26,000

Jacques Selosse, Rosé NV

Avize

Three in individual original cartons

481 9 bottles

per lot HK\$14,000-20,000

Jacques Selosse, Rosé NV

Avize

In six-bottle original cartons

482 12 bottles

per lot HK\$19,000-28,000

Jacquesson, Sillery 1996

Dizy

In six-bottle original cartons

483 12 bottles

per lot HK\$10,000-15,000

Krug 2002

Reims

In original carton

484 6 bottles

per lot HK\$11,000-17,000

Krug Rosé NV

Reims

In three-bottle original cartons

485 12 bottles

per lot HK\$15,000-22,000



Mixed 2000 Philipponnat & Veuve Clicquot Rosé

Philipponnat Clos des Goisses Rosé

In original carton (6)

Veuve Clicquot Rosé

One slightly damaged label (6)

486 12 bottles *per lot* HK\$12,000-18,000

Mixed Champagne

Charles Heidsieck Blanc des Millénaires 1995

US import back labels (6)

Pommery Cuvée Louise 1999

In six-bottle original cartons (9)

Pol Roger Winston Churchill 2002

In original carton magnums (3)

487 3 magnums and 15 bottles *per lot* HK\$17,000-26,000

Château Calon-Ségur 1982

Saint-Estéphe, 3ème cru classé

In original wooden case. Levels into neck

488 12 bottles *per lot* HK\$12,000-18,000

1995 BORDEAUX VINTAGE REPORT

After the previous less inspiring four vintages, 1995 was much welcomed by trade and consumers alike. It was the first major en primeur vintage sales campaign since 1990; perhaps overhyped with prices to match. Yet it has turned out well, to the extent that I am tempted to add an extra star. But let's see.

The growing season started well, early and consistent, following a very mild winter with substantial rainfall to help replenish the water level. Bud break was regular, with rapid flowering before the end of May. The driest summer for 20 years, unusually hot too, up to 30 degrees C. Véraison was also early. In short, all was set for an exceptional vintage. Picking started early on 11 September, but was almost immediately interrupted by heavy rain which then subsided into light showers. These lasted until the 20th, after which most châteaux resumed picking in increasingly warm weather ending with an Indian summer.

Some Merlots were caught by the early rain but Cabernet Franc and Cabernet Sauvignon were very successful, the latter achieving almost unheard of sugar levels. Overall, the wines are ripe, firm, with considerable charm and a good fortune. Michael Broadbent M.W.

1995 年波爾多年份報告

經歷驚喜欠奉的四年後，1995 年的出品大受業界人士和消費者歡迎。當年是 1990 年以來首項大型期酒銷售計劃，但有言過其實之嫌，價格亦偏高。然而，此年份陳年表現理想，我甚至有意為它再添一星，但暫時先靜觀其變。

生長期提早開始，氣候一致，隨後的冬季氣候溫和，雨量充沛，有效補充水位。葡萄藤發芽正常，5 月底前迅速開花，後來遇上 20 年來最乾燥的夏季，而且異常炎熱，氣溫高達攝氏 30 度。果實亦較早成熟。簡單而言，造就非凡年份的條件皆備。酒莊於 9 月 11 日提早收割，但隨即受大雨阻礙，其後雨勢轉弱，一直延續至 9 月 20 日。停雨後大部分酒莊也在日益和暖的天氣下再次收割，採收完結時天氣已非常炎熱。

部分梅洛葡萄受提早降雨影響，但品麗珠和赤霞珠非常理想，後者甜度之高更是前所未見。整體而言，此年份的出品成熟，單寧厚實，迷人討喜，而且頗得天時地利。葡萄酒大師米高·布羅德班

Château Cos d'Estournel 1995

Saint-Estéphe, 2ème cru classé

In original wooden case. Levels into neck

489 6 bottles *per lot* HK\$6,500-9,500

Château Cos d'Estournel 2009

Saint-Estéphe, 2ème cru classé

In six-bottle original wooden cases

490 12 bottles *per lot* HK\$18,000-26,000

Château Lafite-Rothschild 1990

Pauillac, 1er cru classé

In twelve-bottle original wooden case. The Wine Society slip labels.

Levels into neck

491 6 bottles *per lot* HK\$26,000-40,000

Château Lafite-Rothschild 2011

Pauillac, 1er cru classé

In banded six-bottle original wooden cases

492 12 bottles *per lot* HK\$35,000-55,000

493 12 "

Château Lafite-Rothschild 2012

Pauillac, 1er cru classé

In banded six-bottle original wooden cases

494 12 bottles *per lot* HK\$35,000-55,000

495 12 "

496 12 "

Carruades de Lafite-Rothschild 2010

Pauillac

In banded six-bottle original wooden cases

497 12 bottles *per lot* HK\$16,000-24,000

Château Latour 1986

Pauillac, 1er cru classé

In original wooden case. Level into neck

498 1 jeroboam *per lot* HK\$17,000-26,000

Château Latour 1990

Pauillac, 1er cru classé

In original wooden case. Excellent appearance with original tissues.

Levels base of neck

499 12 bottles *per lot* HK\$65,000-95,000



CHATEAU
Calon-Ségur
GRAND CRU CLASSE
SAINT-ESTEPHE

Récolte
1982

MIS
EN BOUTEILLE
AU CHATEAU

Appellation Saint-Estèphe contrôlée

CHATEAU
Calon-Ségur
GRAND CRU CLASSE
SAINT-ESTEPHE

Récolte
1982

MIS
EN BOUTEILLE
AU CHATEAU

Appellation Saint-Estèphe contrôlée

CALON-SÉGUR RÉCOLTANT
SAINT-ESTÈPHE (GIRONDE) FRANCE

CHATEAU
Calon-Ségur
GRAND CRU CLASSE
SAINT-ESTEPHE

Récolte
1982

MIS
EN BOUTEILLE
AU CHATEAU

Appellation Saint-Estèphe contrôlée

CALON-SÉGUR RÉCOLTANT
SAINT-ESTÈPHE (GIRONDE) FRANCE

Lot 488

Château Mouton-Rothschild 2006*Pauillac, 1er cru classé**In banded original wooden case*500 6 bottles *per lot* HK\$18,000-26,000**Château Mouton-Rothschild 2006***Pauillac, 1er cru classé**In banded original wooden case*501 12 bottles *per lot* HK\$35,000-55,000**2011 BORDEAUX VINTAGE REPORT**

I call this the "back-to-front vintage", with summer in the spring and spring in the summer. It made a tremendously early start in all those unusually warm sunny days of spring, and this ensured, rather like in 1990, that it would be one of the earliest harvests on record. Then the indifferent cloudy summer prevented any build-up of great concentration, making for lighter, more elegant wines than the previous two vintages, with great purity and definition. They have recently gained middle-weight, showing lovely ripeness that was less noticeable at the outset and that presumably comes from the unusually hot dry harvest conditions in September, which were the vintage's real salvation. Bill Blatch

2011 年波爾多年份報告

我稱之為「本末倒置的年份」，因為夏季與春季的天氣剛好倒轉。春天異常溫暖晴朗，葡萄生長期極早開始，可望如 1990 年般成為有史以來最早收成的年份之一。但夏季天氣多雲，妨礙酸度集中，令出品比過往兩年更輕盈優雅，純淨度及鮮明度皆非常出眾。最近葡萄酒已形成中度酒體，初步未見突出的成熟口感討喜，估計是 9 月收割期的異常炎熱乾燥天氣所致，正好挽救了此年份的出品。比爾·布拉齊

Château Mouton-Rothschild 2011*Pauillac, 1er cru classé**In banded six-bottle original wooden cases*502 12 bottles *per lot* HK\$28,000-42,000**Château Mouton-Rothschild 2012***Pauillac, 1er cru classé**In banded six-bottle original wooden cases*503 12 bottles *per lot* HK\$28,000-42,000**Château Pichon-Longueville, Baron 2005***Pauillac, 2ème cru classé**In six-bottle original wooden cases*504 24 bottles *per lot* HK\$18,000-26,000**Château Pichon-Longueville, Baron 2010***Pauillac, 2ème cru classé**In three-bottle original wooden cases*505 24 bottles *per lot* HK\$20,000-30,000**Château Pichon-Longueville, Lalande 1982***Pauillac, 2ème cru classé**In original wooden case. Slightly damaged capsules. Slightly stained labels. Levels: ten base of neck, two top-shoulder*506 12 bottles *per lot* HK\$50,000-75,000**Mixed Château Batailley & Château Pichon Lalande****Château Batailley 2009***In original wooden case*

magnums (6)

Château Pichon-Longueville, Lalande 2013*In six-bottle original wooden cases*

(12)

507 6 magnums and 12 bottles *per lot* HK\$9,000-13,000**Château Léoville-Poyferré 2000***Saint-Julien, 2ème cru classé**In original wooden cases*508 24 bottles *per lot* HK\$24,000-38,000**Mixed 2011 Château Pontet-Canet & Château Ducru-Beaucaillou****Château Pontet-Canet***In original wooden case*

(6)

Château Ducru-Beaucaillou*In six-bottle original wooden cases*

(12)

509 18 bottles *per lot* HK\$8,500-13,000**Mixed 2006 & 2010 Château Gruaud-Larose****2006**

(12)

2010

(12)

*In original wooden cases*510 24 bottles *per lot* HK\$9,000-13,000**Château Palmer 1983***Cantenac (Margaux), 3ème cru classé**In six-magnum original wooden case. Slightly damaged capsules.**Slightly stained labels. Levels into neck*511 3 magnums *per lot* HK\$19,000-28,000**Château Palmer 1989***Cantenac (Margaux), 3ème cru classé**In original wooden case. Late release. Excellent appearance. Levels into neck*512 12 bottles *per lot* HK\$24,000-35,000

Château Haut-Brion 2012*Pessac (Graves), 1er cru classé**In original wooden cases*

513	12 bottles	<i>per lot</i> HK\$26,000-40,000
514	12 "	

Château La Mission-Haut-Brion 2009*Pessac (Graves), cru classé**In original wooden case*

515	12 bottles	<i>per lot</i> HK\$30,000-45,000
-----	------------	----------------------------------

Château La Mission-Haut-Brion 2014*Pessac (Graves), cru classé**In six-bottle original wooden cases*

516	12 bottles	<i>per lot</i> HK\$14,000-20,000
-----	------------	----------------------------------

Mixed Château Kirwan & Château Giscours**Château Kirwan 2005***In original wooden case*

(12)

Château Giscours 2010*In six-bottle original wooden cases*

(12)

517	24 bottles	<i>per lot</i> HK\$8,500-13,000
-----	------------	---------------------------------

Mixed Château Chasse Spleen & Château Haut Bailly**Château Chasse Spleen 2006**

(12)

Château Haut Bailly 2008

(12)

In original wooden cases

518	24 bottles	<i>per lot</i> HK\$8,000-12,000
-----	------------	---------------------------------

Château Clinet 2009*Pomerol**In original wooden case*

519	12 bottles	<i>per lot</i> HK\$18,000-26,000
-----	------------	----------------------------------

Mixed 2011 Château Clinet & Vieux-Château-Certan**Château Clinet**

(12)

Vieux-Château-Certan

(6)

In original wooden cases

520	18 bottles	<i>per lot</i> HK\$9,000-14,000
-----	------------	---------------------------------

Vieux-Château-Certan 1982*Pomerol**In slightly damaged original wooden case. Level into neck*

521	1 impériale	<i>per lot</i> HK\$13,000-19,000
-----	-------------	----------------------------------

Château La Violette 2008*Pomerol**In six-bottle original wooden cases*

522	12 bottles	<i>per lot</i> HK\$15,000-22,000
-----	------------	----------------------------------

Le Pin 2011*Pomerol**In banded original wooden case*

523	3 bottles	<i>per lot</i> HK\$28,000-42,000
-----	-----------	----------------------------------



Lot 511

Le Pin 2012

Pomerol

In original wooden case

524 6 bottles

per lot HK\$60,000-90,000

2000 BORDEAUX VINTAGE REPORT

Unsurprisingly, the 2000 vintage was eagerly awaited with a combination of hope and anxiety; merchants anticipated substantial trade to mark the millennium. In the event, most people were reasonably satisfied.

The growing season, as always in Bordeaux, was by no means straight-forward. The New Year and spring were mild, with above-average temperatures in March, resulting in early budbreak. However, though the warmth continued in April and May, it was wet, flowering starting at the end of the month. The damp conditions continued through a depressingly cloudy and humid June and July. What saved the day was almost unbroken sunshine without rain from August through September, resulting in fine ripening conditions favouring the Merlot and, for those who waited and timed it right, Cabernet Sauvignon. Unquestionably, this was a very good year, fairly uniform in quality with some really outstanding wines. Michael Broadbent M.W.



Lot 524

2000 年波爾多年份報告

各界懷著希望與焦慮的心情期待 2000 年份，酒商預料千禧年之際將會創下巨額成交量。結果大部分人也如願以償。

一如以往，此年的種植期也是一波三折。新年及春季氣候溫和，3 月氣溫高於平均水平，令葡萄藤提早發芽。溫暖天氣延續至 4 月及 5 月，但因天氣潮濕，開花期在 5 月底開始。6 月及 7 月繼續潮濕，而且天陰多雲。幸好 8 月及 9 月放晴，未有降雨，為梅洛葡萄締造成熟的有利條件，而有耐性又看準時機的莊園，赤霞珠的收成亦理想。2000 年無疑是非常優秀的年份，品質頗為一致，個別出品則出類拔萃。葡萄酒大師米高·布羅德班

Château L'Eglise Clinet 2000

Pomerol

In original wooden case

525 12 bottles

per lot HK\$24,000-35,000

Château Trotanoy 2009

Pomerol

In six-bottle original wooden cases

526 12 bottles

per lot HK\$20,000-30,000

Château Ausone 2006

Saint-Emilion, 1er grand cru classé (A)

In original wooden case

527 6 bottles

per lot HK\$18,000-26,000

Château Ausone 2007

Saint-Emilion, 1er grand cru classé (A)

In banded original wooden case

528 6 bottles

per lot HK\$15,000-22,000

Château Ausone 2012

Saint-Emilion, 1er grand cru classé (A)

In banded six-bottle original wooden cases

529 12 bottles

per lot HK\$32,000-48,000

Château Cheval-Blanc 1998

Saint-Emilion, 1er grand cru classé (A)

In six-bottle original wooden cases

530 12 bottles

per lot HK\$42,000-65,000

Château Cheval-Blanc 2001

Saint-Emilion, 1er grand cru classé (A)

531 7 bottles

per lot HK\$17,000-24,000

Château Le Tertre-Roteboeuf 2005

Saint-Emilion, grand cru classé

In six-bottle original wooden cases with damaged lids

532 12 bottles

per lot HK\$14,000-20,000

533 12 "

Château Valandraud 2000

Saint-Emilion, grand cru classé

In original wooden case

534 12 bottles

per lot HK\$13,000-19,000

	Mixed Château Canon-La-Gaffelière & Château Quinault L'Enclos		
	Château Canon-La-Gaffelière 2000	magnums (6)	
	Château Quinault L'Enclos 2001	(12)	
535	6 magnums and 12 bottles		per lot HK\$10,000-16,000
	Château d'Yquem 1999		
	<i>Sauternes, 1er grand cru classé</i>		
	<i>In twelve-half bottle original wooden cases</i>		
536	16 half bottles		per lot HK\$8,500-13,000
	Mixed 2003 & 2005 Château Rieussec		
	2003	(12)	
	2005	half-bottle (24)	
	<i>In original wooden cases</i>		
537	12 bottles and 24 half-bottles		per lot HK\$6,500-9,500
	Liquid Gold Assortment 2009		
	Château Suduiraut	half-bottle (6)	
	Château Doisy-Vedrines	half-bottle (6)	
	Château La Tour-Blanche	half-bottle (6)	
	Château Guiraud	half-bottle (6)	
	<i>In original wooden case</i>		
538	24 half bottles		per lot HK\$4,000-6,000

	Mixed 2011-2013 Coche Dury, Meursault		
	2011	(3)	
	2012	(2)	
	2013	(6)	
539	11 bottles		per lot HK\$22,000-35,000
	Mixed 2011-2013 Domaine des Comtes Lafon, Montrachet		
	2011	(1)	
	2012	(1)	
	2013	(1)	
	<i>In original wooden cases</i>		
540	3 bottles		per lot HK\$24,000-35,000
	Domaine des Comtes Lafon, Meursault-Perrières 2004		
	<i>1er Cru, Côte de Beaune</i>		
	<i>In original carton</i>		
541	12 bottles		per lot HK\$18,000-26,000



	Mixed 2008 & 2009 Domaine des Comtes Lafon		
	Meursault 2008	(2)	
	Meursault Clos de la Barre 2008	(3)	
	Meursault Clos de la Barre 2009	(3)	
	Meursault Gouttes d'Or 2008	(2)	
	Meursault Gouttes d'Or 2009	(1)	
	Meursault Les Charmes 2008	(2)	
	Meursault Les Charmes 2009	(1)	
	Meursault Les Genevrières 2008	(2)	
	Meursault Les Genevrières 2009	(1)	
542	17 bottles		per lot HK\$16,000-24,000

Domaine des Comtes Lafon Assortment 2011 & 2012

	Meursault Gouttes d'Or 2011	(1)	
	Meursault Gouttes d'Or 2012	(1)	
	Meursault Les Charmes 2011	(1)	
	Meursault Les Charmes 2012	(1)	
	Meursault Les Genevrières 2011	(1)	
	Meursault Les Genevrières 2012	(1)	
	Meursault Perrières 2011	(1)	
	Meursault Perrières 2012	(1)	
	Meursault Bouchères 2011	(1)	
	Meursault Bouchères 2012	(1)	
	Meursault Porusots 2011	(1)	
	Meursault Porusots 2012	(1)	
	<i>In banded original wooden cases</i>		
543	12 bottles		per lot HK\$19,000-26,000

Mixed Domaine des Comtes Lafon Red

	Monthelie les Duresses 2009	(2)	
	Volnay 2009	(2)	
	Volnay Champans 2009	(2)	
	Volnay Santenots du Milieu 2011		
	<i>In original carton</i>	(12)	
544	18 bottles		per lot HK\$8,000-12,000

Mixed 2010 Domaine des Héritiers du Comte Lafon

	Mâcon-Chardonnay Clos de la Crochette	(3)	
	Mâcon-Milly-Lamartine	(2)	
	Mâcon-Milly-Lamartine Clos du Four	(2)	
	Mâcon-Uchizy Les Maranches	(2)	
	Viré-Clessé	(3)	
545	12 bottles		per lot HK\$2,000-3,200

Mixed François Mikulski

	Meursault Charmes 2009		
	<i>In six-bottle original cartons</i>	(8)	
	Meursault Charmes VV 2013		
	<i>In three-magnum original cartons</i>	magnums (6)	
	Meursault Charmes VV 2014		
	<i>In original carton</i>	(6)	
	Meursault Charmes 2015	(3)	
546	6 magnums and 17 bottles		per lot HK\$17,000-24,000

François Mikulski, Meursault Genevrières 2015

	<i>1er Cru, Côte de Beaune</i>		
547	18 bottles		per lot HK\$14,000-20,000

Guy Amiot, Montrachet 2009

	<i>Grand Cru, Côte de Beaune</i>		
	<i>In original carton</i>		
548	12 bottles		per lot HK\$28,000-42,000

Henri Boillot, Criots Bâtard-Montrachet 2007

	<i>Grand Cru, Côte de Beaune</i>		
	<i>US import slip labels</i>		
549	9 bottles		per lot HK\$10,000-15,000

Labouré-Roi, Montrachet 1996

	<i>Grand Cru, Côte de Beaune</i>		
	<i>In six-bottle original wooden cases</i>		
550	12 bottles		per lot HK\$15,000-22,000

Domaine Leflaive

The earliest family history goes back to 1717 when Claude Leflaive settled in Puligny-Montrachet. The Domaine of today more directly goes back to Joseph Leflaive (1870-1953), who was a native of Puligny-Montrachet. In 1905, when Burgundy had not yet recovered from the effect of the phylloxera epidemic and therefore vineyards were for sale at a very low price, Leflaive was able to buy 25 hectares. In 1990 Anne-Claude Leflaive and her cousin Vincent Leflaive took over the management of the domain. Today this famous Domaine is run by Anne-Claude Leflaive.

The Domaine owns almost 25 hectares of vineyards mainly located in and around Puligny-Montrachet. Their holdings include 0.08 hectares of Le Montrachet, 2 hectares of Chevalier-Montrachet, 1.91 hectares of Bâtard-Montrachet, 1.6 hectares of Bienvenues-Bâtard-Montrachet and Puligny-Montrachet Premier Crus; Le Clavoillon, Les Combettes, Les Folatières and Les Pucelles.

Domaine Leflaive has been totally biodynamic since 1997 and Pierre Morey was estate manager since 1989 until Eric Remy took over in 2008. The wines are fermented at between 18 to 24° C, given 10-40% light toast new oak (there is one 500-litre cask for the Montrachet) and, after 12 months, racked into stainless steel where they wait another 6 months before bottling. This is the very summit of white Burgundy. Outstanding wines that have the capacity to be very long-lived and develop richness, depth and complexity with bottle-age. These are some of the most highly sought-after white wines in the world.

Domaine Leflaive, Bâtard-Montrachet 2005

	<i>Grand Cru, Côte de Beaune</i>		
	<i>One slightly damaged label</i>		
551	5 bottles		per lot HK\$15,000-22,000

Domaine Leflaive, Chevalier-Montrachet 2001

	<i>Grand Cru, Côte de Beaune</i>		
552	12 bottles		per lot HK\$42,000-65,000

Mixed 2005 & 2009 Domaine Leflaive, Chevalier-Montrachet 2005

		(3)	
		magnum (1)	
553	1 magnum and 3 bottles		per lot HK\$17,000-24,000

Domaine Leflaive, Bienvenues-Bâtard-Montrachet 2009
Grand Cru, Côte de Nuits
Twelve in original wooden case
 554 15 bottles *per lot* HK\$32,000-50,000

Mixed Domaine Leflaive Grand Crus

Bâtard-Montrachet 2009 (1)
Bâtard-Montrachet 2010 (1)
Bienvenues-Bâtard-Montrachet 2009 (1)
Bienvenues-Bâtard-Montrachet 2010 (1)
Chevalier-Montrachet 2009 (1)
 555 5 bottles *per lot* HK\$12,000-18,000

Domaine Leflaive, Puligny-Montrachet Clavoillon 2005

1er Cru, Côte de Beaune
In six-bottle original wooden cases
 556 12 bottles *per lot* HK\$13,000-19,000

Mixed Domaine Leflaive, Puligny Montrachet 1er Crus

Puligny-Montrachet Folatières 2004 (6)
Four slightly damaged labels
Puligny-Montrachet Clavoillon 2009 (6)
Puligny-Montrachet Clavoillon 2010 (3)
 557 15 bottles *per lot* HK\$14,000-20,000

Domaine Leflaive, Puligny-Montrachet Les Pucelles 1999

1er Cru, Côte de Beaune
Slightly stained labels
 558 6 bottles *per lot* HK\$10,000-15,000

Mixed Domaine Leflaive, Puligny-Montrachet Les Pucelles

2005 (6)
2009 (3)
2010 (2)
 559 11 bottles *per lot* HK\$17,000-24,000

Mixed Domaine Leflaive, Puligny-Montrachet

2005 (3)
2006 (3)
2007 (3)
2008 (2)
2009 (3)
2010 (3)
 560 17 bottles *per lot* HK\$11,000-16,000

Mixed Domaine Leflaive, Burgogne Blanc

2005 (3)
One damaged capsule
2006 (2)
2009 (9)
In twelve-bottle original wooden case
2010 (2)
 561 16 bottles *per lot* HK\$6,000-9,000



Mixed 2010 Domaine Leflaive
Mâcon-Verzé (6)
Meursault sous le Dos d'Âne
Twelve in original wooden case (18)
 562 24 bottles *per lot* HK\$12,000-19,000

Marc Colin, Montrachet 2009
Grand Cru, Côte de Beaune
In original wooden case
 563 3 bottles *per lot* HK\$10,000-15,000

Mixed 1994 Domaine Ramonet
Montrachet magnum (1)
Damaged capsule. Slight sign of old seepage. Level 5cms
Chassagne-Montrachet Les Ruchottes magnums (3)
Slightly damaged capsules. Levels: one 1.5cms, two 2.5cms
Chassagne-Montrachet Morgeot Blanc half-bottles (12)
Six very slightly stained labels. One slightly damaged capsule.
Levels 1.5cms or better
 564 4 magnums and 12 half bottle *per lot* HK\$12,000-18,000

Domaine Ramonet Assortment 2013

Bâtard-Montrachet
Slightly damaged label (1)
Chassagne-Montrachet La Boudriotte (3)
Chassagne-Montrachet Les Ruchottes (3)
Chassagne-Montrachet 1er Cru Morgeot Blanc (1)
Chassagne-Montrachet 1er Cru Les Vergers (1)
Montrachet (1)
Puligny-Montrachet Champs-Canet (1)
Puligny-Montrachet Les Enseignères (1)
In original carton
 565 12 bottles *per lot* HK\$16,000-26,000

Mixed 2014 Jean Claude Ramonet

Bâtard-Montrachet (1)
Bienvenues-Bâtard-Montrachet (1)
Chassagne-Montrachet La Boudriotte Rouge (1)
Chassagne-Montrachet Les Caillerets (1)
Chassagne-Montrachet Clos St. Jean Rouge
Slightly stained label (1)
Chassagne-Montrachet Morgeot (1)
Chassagne-Montrachet Morgeot Rouge (1)
Chassagne-Montrachet Les Ruchottes (2)
Montrachet (1)
Puligny-Montrachet Champs-Canet (2)
 566 12 bottles *per lot* HK\$22,000-32,000



Lot 565

Vincent Girardin, Chevalier-Montrachet 2006
Grand Cru, Côte de Beaune
In six-bottle original wooden cases
 567 12 bottles per lot HK\$14,000-20,000

Vincent Girardin, Bienvenues-Bâtard-Montrachet 2009
Grand Cru, Côte de Beaune
In six-bottle original cartons
 568 12 bottles per lot HK\$9,000-14,000

**Mixed 2006 Vincent Girardin
 Bienvenues-Bâtard-Montrachet**
In original wooden case (6)
Meursault Perrières
In original carton (12)
 569 18 bottles per lot HK\$11,000-16,000

Mixed William Fèvre 2008
Chablis Les Preuses (12)
Chablis Valmur (12)
Chablis Vaudésir (12)
In original cartons
 570 36 bottles per lot HK\$14,000-22,000

Alain Burguet, Chambertin Clos de Bèze 2010
Grand Cru, Côte de Nuits
In original carton
 571 6 bottles per lot HK\$9,500-14,000

Albert Bichot, Chambertin 2002
Grand Cru, Côte de Nuits
In six-bottle original wooden cases
 572 12 bottles per lot HK\$11,000-17,000

Anne-Françoise Gros, Richebourg 1999
Grand Cru, Côte de Nuits
In original carton. Signs of old seepage. Two stained vintage neck labels
 573 6 bottles per lot HK\$16,000-24,000

Mixed 2012 Anne-Françoise Gros
Chambolle-Musigny (2)
Echézeaux (1)
Richebourg (1)
Savigny-les-Beaune Clos des Guettes (2)
Vosne-Romanée Clos de la Fontaine (2)
Vosne-Romanée Maizières (2)
Vosne-Romanée Aux Réas (2)
 574 12 bottles per lot HK\$7,000-10,000



Lot 574

	Mixed Domaine Anne Gros, Richebourg		
	2007	(3)	
	2009		
	<i>In original carton</i>	(12)	
575	15 bottles		per lot HK\$60,000-90,000

Mixed Domaine Anne Gros

	Richebourg 2010	(1)	
	Clos de Vougeot Le Grand Maupertui 2012	(12)	
576	13 bottles		per lot HK\$16,000-24,000

Mixed 2013 Domaine Anne Gros

	Clos Vougeot Le Grand Maupertui	(1)	
	Echézeaux les Lochausses	(1)	
	Bourgogne Hautes-Côtes de Nuits Cuvée Marine	(1)	
	Nuits St. Georges Les Damodes	(1)	
	Richebourg	(1)	
	Vosne-Romanée Les Barreaux	(1)	
577	6 bottles		per lot HK\$6,000-8,500

Domaine Armand Rousseau

The Domaine was started at the beginning of the 20th century by Armand Rousseau who, at the age of 18, inherited several plots of vineyards in Gevrey Chambertin.

Today the Domaine's vineyards have a surface area of 15.33 hectares of which 3 hectares are of Village Appellation, 3.77 hectares of 1er Cru Appellation and 8.51 hectares of Grands Crus A.O.C., all situated in the communes of Gevrey-Chambertin and Morey-Saint-Denis. The vines are mostly very old with an average age of 40 to 45 years. The vines are 100% Pinot Noir with 11,000 vines planted per hectare.

The method of viticulture in the vineyards is traditional with low yield, from 30 to 40 hectoliters per hectare. No fertilizer has been used for many years. "Debudbing" and green harvest are systematically done in productive years in order to optimize the maturity of grapes and the concentration of phenolic components.

Vinification is done in a very traditional style with 90% destemming, about 18 to 20 days fermentation in open stainless steel vats with regular "pumping over" and "pigeage", and a strict control of temperatures with a maximum of 31-34°C.

The wine is then aged in 100 % new oak barrels for Chambertin, 90 to 100% for Chambertin Clos de Bèze, 70 to 90% for Clos Saint Jacques and 20% for Clos des Ruchottes.

The average annual production is 65,000 bottles per year. The wines from Domaine Armand Rousseau have developed over the generations but have always kept the same spirit as when Armand and Charles were making them. The "Rousseau touch" is a style of wine instantly recognizable. Their wines are typically Burgundian: fine, elegant and an honest, true expression of the vineyards through the Pinot Noir grape and a little intervention from the winemaker.

阿曼盧梭酒莊

酒莊由阿曼·盧梭於二十世紀初創立，當時他年僅 18 歲，繼承了位於熱夫雷香貝丹的幾個葡萄園。

酒莊目前佔地 15.33 公頃，當中包括 3 公頃村莊級葡萄園、3.77 公頃一級葡萄園及 8.51 公頃特級葡萄園，全部位於熱夫雷香貝丹和莫雷聖德尼。葡萄園內以老葡萄樹居多，平均樹齡 40 至 45 年，全部為黑皮諾，每公頃種植 11,000 棵葡萄樹。

酒莊以傳統方法種植葡萄，產量低，每公頃收成只有 30 至 40 百升。多年來，葡萄園也沒有使用肥料，反而在豐收的年份有系統地採用截芽及綠色採收方法，令葡萄更加成熟，亦令酚的含量更高。酒莊也沿用傳統釀酒法，為 90% 的葡萄除莖後，將葡萄放在開放式的不銹鋼大桶內發酵約 18 至 20 日，定時「淋皮」及「踩皮」，並嚴格控制溫度於攝氏 31 至 34 度。

然後，製作香貝丹葡萄酒的液體會放入全新的橡木桶陳年，製作香貝丹日葡萄酒的液體則會使用九成新至全新的橡木桶，而聖雅克葡萄酒及盧梭葡萄酒則分別使用七成至九成新的木桶，以及兩成新的木桶。酒莊平均產量為每年 65,000 瓶，八成不同等級的佳釀均於海外銷售，行銷全球 30 多個國家和地區。酒莊亦會為法國的鑑賞家、酒商及星級餐廳供應佳釀。

阿曼盧梭酒莊的葡萄酒經過多個世代的演變，但一直體現創辦人阿曼與查理斯的精神。以「盧梭之手」釀造的珍釀自成一格，充滿勃艮第特色，口感細膩優雅、樸實出眾，透過黑皮諾葡萄與釀酒師的巧手，展現葡萄園的獨特魅力。

	Armand Rousseau, Chambertin 2005		
	<i>Grand Cru, Côte de Nuits</i>		
578	4 bottles		per lot HK\$48,000-70,000

	Armand Rousseau, Chambertin 2010		
	<i>Grand Cru, Côte de Nuits</i>		
579	6 bottles		per lot HK\$70,000-100,000

	Armand Rousseau, Chambertin 2011		
	<i>Grand Cru, Côte de Nuits</i>		
580	6 bottles		per lot HK\$32,000-48,000

	Armand Rousseau, Chambertin 2012		
	<i>Grand Cru, Côte de Nuits</i>		
	<i>In original carton</i>		
581	6 bottles		per lot HK\$48,000-75,000

	Armand Rousseau, Chambertin 2013		
	<i>Grand Cru, Côte de Nuits</i>		
	<i>In six-bottle original cartons</i>		
582	12 bottles		per lot HK\$85,000-130,000

	Armand Rousseau, Chambertin 2014		
	<i>Grand Cru, Côte de Nuits</i>		
	<i>In original carton</i>		
583	6 bottles		per lot HK\$48,000-75,000

	Armand Rousseau, Chambertin-Clos de Bèze 2009		
	<i>Grand Cru, Côte de Nuits</i>		
	<i>Three in original carton</i>		
584	12 bottles		per lot HK\$110,000-160,000

Armand Rousseau, Chambertin-Clos de Bèze 2011
Grand Cru, Côte de Nuits
 585 3 bottles *per lot* HK\$14,000-20,000

Armand Rousseau, Chambertin-Clos de Bèze 2012
Grand Cru, Côte de Nuits
In six-bottle original carton
 586 3 bottles *per lot* HK\$19,000-28,000

Armand Rousseau, Chambertin-Clos de Bèze 2013
Grand Cru, Côte de Nuits
Six in original carton
 587 9 bottles *per lot* HK\$55,000-85,000

Armand Rousseau, Chambertin-Clos de Bèze 2014
Grand Cru, Côte de Nuits
In original carton
 588 6 bottles *per lot* HK\$42,000-65,000

Armand Rousseau, Charmes-Chambertin 2005
Grand Cru, Côte de Nuits
In original carton
 589 12 bottles *per lot* HK\$28,000-42,000

Mixed 2013 & 2014 Armand Rousseau, Charmes-Chambertin
2013 (6)
2014 (6)
In original cartons
 590 12 bottles *per lot* HK\$17,000-26,000

Mixed Armand Rousseau Clos de la Roche & Charmes-Chambertin
2009 Clos de la Roche (6)
2010 Charmes-Chambertin (6)
In original carton
 591 12 bottles *per lot* HK\$26,000-38,000

Armand Rousseau, Clos de la Roche 2005
Grand Cru, Côte de Nuits
In original carton
 592 12 bottles *per lot* HK\$32,000-48,000

Mixed 2009 & 2011 Armand Rousseau Clos de la Roche
2009 (6)
2011 (3)
In original carton
 593 9 bottles *per lot* HK\$16,000-26,000

Armand Rousseau, Ruchottes-Chambertin Clos des Ruchottes 2005
Grand Cru, Côte de Nuits
 594 12 bottles *per lot* HK\$38,000-55,000

Armand Rousseau, Ruchottes-Chambertin Clos des Ruchottes 2010
Grand Cru, Côte de Nuits
In original carton
 595 6 bottles *per lot* HK\$16,000-22,000

Mixed 2011 & 2012 A. Rousseau, Ruchottes-Chambertin Clos des Ruchottes
2011 (3)
2012 (3)
 596 6 bottles *per lot* HK\$13,000-20,000

Armand Rousseau, Ruchottes-Chambertin Clos des Ruchottes 2013
Grand Cru, Côte de Nuits
In original carton
 597 6 bottles *per lot* HK\$12,000-18,000



	Armand Rousseau, Ruchottes-Chambertin Clos des Ruchottes 2014 <i>Grand Cru, Côte de Nuits</i> <i>In original carton</i>				Armand Rousseau, Gevrey-Chambertin Clos Saint Jacques 2014 <i>1er Cru, Côte de Nuits</i> <i>In original carton</i>		
598	6 bottles		<i>per lot</i>	HK\$13,000-20,000	602	6 bottles	<i>per lot</i> HK\$18,000-26,000
	Armand Rousseau, Gevrey-Chambertin Clos Saint Jacques 2010 <i>1er Cru, Côte de Nuits</i>					Armand Rousseau, Gevrey-Chambertin Lavaux Saint-Jacques 2005 <i>1er Cru, Côte de Nuits</i> <i>One slightly damaged label</i>	
599	3 bottles		<i>per lot</i>	HK\$11,000-17,000	603	9 bottles	<i>per lot</i> HK\$17,000-26,000
	Mixed A. Rousseau Gevrey-Chambertin Clos Saint Jacques 2011	(3)				Domaine Arnoux-Lachaux, Romanée-Saint-Vivant 2010 <i>Grand Cru, Côte de Nuits</i> <i>In original carton</i>	
600	6 bottles		<i>per lot</i>	HK\$17,000-26,000	604	12 bottles	<i>per lot</i> HK\$42,000-65,000
	Armand Rousseau, Gevrey-Chambertin Clos Saint Jacques 2013 <i>1er Cru, Côte de Nuits</i> <i>In original carton</i>					Domaine Bachelet, Gevrey-Chambertin Vieilles Vignes 2009 <i>Côte de Nuits</i> <i>In original carton</i>	
601	6 bottles		<i>per lot</i>	HK\$16,000-22,000	605	12 bottles	<i>per lot</i> HK\$6,000-9,000



Lot 609

	Maison Roche de Bellen, Clos de la Roche Collection Bellenum 2002	
	<i>Grand Cru, Côte de Nuits</i>	
	<i>In original carton</i>	
606	6 bottles	<i>per lot</i> HK\$9,000-13,000
	Mixed 2011 & 2012 Cecile Tremblay Chapelle-Chambertin 2011	(12)
	2012	(3)
	<i>In original cartons</i>	
607	15 bottles	<i>per lot</i> HK\$20,000-30,000
	Cecile Tremblay, Chambolle-Musigny Les Cabottes 2009	
	<i>Côte de Nuits</i>	
608	6 bottles	<i>per lot</i> HK\$15,000-22,000
	Cecile Tremblay, Chambolle-Musigny Les Cabottes 2011	
	<i>Côte de Nuits</i>	
	<i>In original carton</i>	
609	12 bottles	<i>per lot</i> HK\$10,000-15,000
	Mixed 2012 & 2013 Cecile Tremblay, Chambolle-Musigny Les Cabottes	
	2012	(6)
	2013	(6)
	<i>In original cartons</i>	
610	12 bottles	<i>per lot</i> HK\$12,000-18,000
	Cecile Tremblay, Vosne-Romanée Les Beaumonts 2009	
	<i>1er Cru, Côte de Nuits</i>	
	<i>In original carton</i>	
611	12 bottles	<i>per lot</i> HK\$26,000-38,000
	Cecile Tremblay, Vosne-Romanée Les Rouges du Dessus 2009	
	<i>1er Cru, Côte de Nuits</i>	
612	6 bottles	<i>per lot</i> HK\$7,500-11,000
	Château de Puligny-Montrachet, Pommard Pézerolles 2005	
	<i>1er Cru, Côte de Beaune</i>	
	<i>Twelve in original carton</i>	
613	18 bottles	<i>per lot</i> HK\$5,500-8,500
	Mixed 2005 Claude Dugat	
	Charmes-Chambertin	(2)
	Griotte-Chambertin	(2)
	Gevrey-Chambertin 1er Cru	(2)
	Gevrey-Chambertin Lavaux St. Jacques	(2)
614	8 bottles	<i>per lot</i> HK\$24,000-35,000

Domaine Comte Georges de Vogüé

Domaine Comte Georges de Vogüé has remained by inheritance in the same family since 1450. Today, it is run by the two granddaughters of Comte Georges de Vogüé, Claire de Causans and Marie de Ladoucette.

The operational management team currently includes three people – Jean-Luc Pépin, who joined the Domaine in 1988, is the sales director, Francois Millet, who joined the Domaine in 1986, is oenologist and winemaker, and finally Eric Bourgogne who joined the Domaine in 1996, is the vineyard manager.

The Domaine's holdings are located entirely in Chambolle-Musigny and encompass notably 70% of Grand Cru Musigny, i.e. 7,20 hectares out of the 10 hectares of the total appellation, 18% of the Grand Cru Bonnes-Mares, i.e. 2,70 hectares out of the 15 hectares of the total appellation and 10% of the Chambolle-Musigny 1er Cru Les Amoureuses, i.e. 0,56 hectares out of the 5,35 hectares of the total appellation.

Among the Domaine's wines, their Musigny is the pinnacle and probably the most sought-after. It hides a great underlying power and strength, the proverbial "iron fist in a velvet glove". As a true evidence of their policy of "no compromise" with the quality, all of the Musigny produced at the Domaine is labelled "Vieilles Vignes" (old vines), i.e. the wine produced from vines of Musigny under 25 years of age is systematically declassified into Chambolle-Musigny (up until the 1994 vintage inclusive) and Chambolle-Musigny 1er Cru (since the 1995 vintage).

喬治沃古伯爵酒莊

喬治沃古伯爵酒莊於 1450 年創立，一直由喬治沃古伯爵家族經營至今。目前，酒莊由喬治沃古伯爵兩名孫女克雷爾·德·高桑及瑪麗·德·拉多奇共同管理。

現時酒莊的日常營運由三人管理，分別是於 1988 年加盟的銷售總監讓-呂克·丕平、於 1986 年加盟的釀酒學家兼釀酒師弗朗索瓦·米勒，以及於 1996 年加盟的葡萄園經理艾瑞克·博古農。

酒莊坐落於香波慕西尼，擁有慕西尼特級葡萄園的 70%（即佔整個產區 10 公頃中的 7.2 公頃）、邦瑪特級葡萄園的 18%（佔整個產區 15 公頃中的 2.70 公頃），以及香波慕西尼愛侶一級葡萄園的 10%（佔整個產區 5.35 公頃中的 0.56 公頃）。

在雲雲出品之中，酒莊釀造的慕西尼葡萄酒最為人推崇，廣受歡迎。酒體剛勁厚實，外柔內剛。酒莊時刻恪守「永不妥協」的原則，確保品質非凡，釀造的慕西尼葡萄酒皆會貼上「vieilles vignes」陳釀標籤，即樹齡不足 25 年的慕西尼葡萄園會自動降級為香波慕西尼葡萄酒（1994 年或之前釀造的葡萄酒），以及香波慕西尼一級葡萄酒（1995 年以後釀造的葡萄酒）。

	Comte Georges de Vogüé, Musigny Vieilles Vignes 2009	
	<i>Grand Cru, Côte de Nuits</i>	
	<i>In original wooden case</i>	
615	6 bottles	<i>per lot</i> HK\$24,000-35,000

	Comte Georges de Vogüé, Musigny Vieilles Vignes 2010	
	<i>Grand Cru, Côte de Nuits</i>	
616	3 bottles	<i>per lot</i> HK\$12,000-18,000

	Comte Georges de Vogüé, Musigny Vieilles Vignes 2011	
	<i>Grand Cru, Côte de Nuits</i>	
617	3 bottles	<i>per lot</i> HK\$7,000-11,000

	Comte Georges de Vogüé, Musigny Vieilles Vignes 2012	
	<i>Grand Cru, Côte de Nuits</i>	
	<i>In six-bottle original wooden cases</i>	
618	12 bottles	<i>per lot</i> HK\$45,000-65,000



Mixed 2014 Comte Georges de Vogüé, Musigny Vieilles Vignes 2014
 2014
In original wooden case
 619 1 magnum and 6 bottles magnum (1)
(6)
per lot HK\$30,000-45,000

Mixed 2012 Comte Georges de Vogüé
Musigny Vieilles Vignes (3)
Bonnes-Mares (3)
 620 6 bottles *per lot* HK\$18,000-24,000

Comte Georges de Vogüé, Bonnes Mares 2005
Grand Cru, Côte de Nuits
In six-bottle original wooden cases
 621 12 bottles *per lot* HK\$38,000-55,000

Comte Georges de Vogüé, Bonnes Mares 2009
Grand Cru, Côte de Nuits
 622 12 bottles *per lot* HK\$26,000-38,000

Comte Georges de Vogüé, Bonnes Mares 2014
Grand Cru, Côte de Nuits
In six-bottle original wooden cases
 623 12 bottles *per lot* HK\$26,000-38,000

Comte Georges de Vogüé, Chambolle-Musigny Les Amoureuses 2005
1er Cru, Côte de Nuits
In original carton
 624 6 bottles *per lot* HK\$24,000-35,000

Comte Georges de Vogüé, Chambolle-Musigny Les Amoureuses 2006
1er Cru, Côte de Nuits
In original wooden case
 625 6 bottles *per lot* HK\$18,000-26,000

Mixed 2014 de Vogüé, Bonnes Mares & Chambolle-Musigny Les Amoureuses
Bonnes Mares magnum (1)
Chambolle-Musigny Les Amoureuses magnum (1)
 626 2 magnums *per lot* HK\$10,000-16,000

Comte Georges de Vogüé, Chambolle-Musigny 1er Cru 2005
1er Cru, Côte de Nuits
In original carton
 627 6 bottles *per lot* HK\$10,000-15,000

Mixed 2011 & 2014 Comte de Vogue Chambolle Musigny 1er Cru 2011 (3)
2014 magnum (1)
 628 1 magnum and 3 bottles *per lot* HK\$5,500-8,500

Comte Georges de Vogüé, Chambolle-Musigny 1984
Côte de Nuits
In original wooden case. Recent release. Excellent appearance and levels
 629 6 bottles *per lot* HK\$10,000-15,000

Comte Georges de Vogüé, Chambolle-Musigny 2005
Côte de Nuits
In six-bottle original wooden cases
 630 12 bottles *per lot* HK\$12,000-18,000

Mixed Comte Georges de Vogüé, Chambolle-Musigny 2010 (3)
2011 (3)
2014 magnum (1)
 631 1 magnum and 6 bottles *per lot* HK\$6,000-9,500

Mixed Comte Georges de Vogüé 2013
Musigny Vieilles Vignes (1)
Bonnes Mares (1)
Chambolle-Musigny Les Amoureuses (1)
Chambolle-Musigny 1er Cru (1)
Chambolle-Musigny (1)
In de Vogüé six-bottle wooden cases
 632 5 bottles *per lot* HK\$9,500-14,000
 633 5 "
 634 5 "

Mixed Comte Georges de Vogüé 2014
Musigny Vieilles Vignes (1)
Bonnes Mares (1)
Chambolle-Musigny Les Amoureuses (1)
Chambolle-Musigny 1er Cru (1)
Chambolle-Musigny (1)
In de Vogüé six-bottle wooden cases
 635 5 bottles *per lot* HK\$10,000-15,000

Domaine de la Vougeraie, Bonnes Mares 2009
Grand Cru, Côte de Nuits
In original carton
 636 3 magnums *per lot* HK\$6,000-9,000

Domaine de la Vougeraie, Musigny 2009
Grand Cru, Côte de Nuits
In original carton
 637 6 bottles *per lot* HK\$22,000-32,000

Domaine de la Vougeraie, Musigny 2011*Grand Cru, Côte de Nuits**In three-bottle original wooden cases*638 6 bottles *per lot* HK\$17,000-26,000**Mixed 2012 & 2013 Domaine de la Vougeraie Musigny****2012**

(3)

2013

(3)

*In original cartons*639 6 bottles *per lot* HK\$17,000-26,000**Mixed 2013 Domaine de l'Arlot****Côte de Nuits Villages Clos du Chapeau**

(3)

Nuits-Saint-Georges Clos de L'Arlot

(3)

Nuits-Saint-Georges Clos de L'Arlot Blanc

(3)

Nuits-Saint-Georges Clos des Forets*In original carton*

(12)

640 21 bottles *per lot* HK\$7,000-11,000**Mixed 2013 Domaine de l'Arlot****Nuits-Saint-Georges La Gerbotte Blanc**

(3)

Nuits-Saint-Georges Le Petit Arlot

(3)

Nuits-Saint-Georges Les Petits Plets

(3)

Romanée-St-Vivant

(3)

Vosne-Romanée Les Suchots

(3)

641 15 bottles *per lot* HK\$9,000-14,000**Domaine de la Romanée-Conti**

Domaine de la Romanée-Conti (often abbreviated to DRC) is widely considered to be among the world's greatest wine producers, and has, for many decades, been Burgundy's pre-eminent Domaine. DRC bottles are among the world's rarest, most renowned and most expensive great wines. It takes its name from the Domaine's most famous vineyard, Romanée-Conti. The boundaries of this vineyard were established back in the 16th century, and over time, its name changed from Cros des Cloux, to La Romanée, to Romanée-Conti, after its purchase by King Louis XV's cousin, the Prince de Conti. In 1869 the vineyard passed to Jacques-Marie Duvault-Bloch, ancestor of the current co-owners, the de Villaine family. The Leroy family acquired half ownership in 1942. The Domaine is today jointly managed by representatives of these two families: Aubert de Villaine and Henri-Frédéric Roch.

The Domaine owns almost 28 hectares of vineyards and this includes sole ownership of the 1.81 hectares of Romanée-Conti Grand Cru and the entire 6.06 hectares of La Tâche. They also own holdings of 3.51 hectares of Richebourg, 5.29 hectares of Romanée-Saint-

Vivant, 0.68 hectares of Le Montrachet and cultivate 3.53 hectares of Grands-Echézeaux, with 4.67 hectares of Echézeaux. Occasionally the Domaine produces a Vosne-Romanée Premier Cru Cuvée Duvault-Bloch from younger vines in their Grand Cru vineyards. The Domaine has also started producing Corton from the 2009 vintage after they leased 2.28 hectares of vineyards including parcels in Corton Clos du Roi, Bressandes and Renardes. The Domaine has been at the forefront of viticultural developments and has adopted the biodynamic approach. The Domaine uses vine material from their own vineyards for their re-planting. In 2005, the average age of the Romanée-Conti vines was more than 50 years.

There is no disputing the quality of the wines, particularly their highly sought-after, greatly-prized Romanée-Conti. This is very scarce, as on average only 450 cases are produced each vintage. As Michael Broadbent M.W. stated "It never fails to astonish me that the strips of vines which stretch only a modest number of meters up the very gentle slopes from the outskirts of an equally modest, indeed remarkably rural rambling village of Vosne, are capable of producing wines of such world class quality". This wine needs time and evolves incredible finesse, smoothness, complexity and length of flavour, with bottle-age.

羅曼尼·康帝酒莊

羅曼尼·康帝酒莊是全球公認的頂級酒莊，數十年來被奉為勃艮第名莊，其出品名釀不但最罕有，亦價值連城。酒莊名字源自著名的羅曼尼·康帝葡萄園，葡萄園早於十六世紀已確立其範圍，多年來曾先後易名為克洛及羅曼尼，直至國王路易十五的堂弟康帝親王收購莊園，才改稱羅曼尼·康帝園。1869年，現任莊主德維蘭家族的先祖雅克·瑪利·迪沃·布洛謝買下葡萄園，並於1942年將一半業權售予樂樺家族。目前酒莊由奧貝爾·德維蘭及亨利·弗雷德里克·洛奇兩大家族的代表共同管理。

酒莊擁有近 28 公頃葡萄園，包括全權擁有的 1.81 公頃羅曼尼·康帝特級園及 6.06 公頃拉塔希園，還有 3.51 公頃李其堡園、5.29 公頃羅曼尼·聖維旺園、0.68 公頃蒙哈樹園、3.53 公頃大依瑟素園及 4.67 公頃依瑟素園。酒莊偶爾會採用特級葡萄園內樹齡較淺葡萄樹的果實釀造沃恩·羅曼尼特釀。酒莊亦租用 2.28 公頃葡萄園，包括科爾登·魯瓦園、布雷薩德園及雷納德園，並由 2009 年起釀造科爾登葡萄酒。酒莊一直是葡萄種植發展的先驅，採用生物動力法種植葡萄，並以現有的葡萄樹重新種植葡萄。2005 年，羅曼尼·康帝酒莊葡萄樹的平均樹齡超過 50 年。

羅曼尼·康帝酒莊的出品毋庸置疑，其中炙手可熱的羅曼尼·康帝特釀更是備受推崇。此佳釀產量極少，每個年份平均只有 450 箱。如葡萄酒專家麥克·布勞德班所言：「每次品嚐此酒也令我驚豔。葡萄在簡樸的沃恩村外的緩坡生長，雖然園地只有短短數米，卻能孕育如此優質的世界級美酒。」此酒需要時間醒酒，以展現極致細膩順滑的口感與複雜陳次，味道綿長。

Domaine de la Romanée-Conti, Assortment 2008**Romanée-Conti***Very slightly damaged label*

(1)

La Tâche

(2)

Richebourg

(2)

Romanée-Saint-Vivant

(2)

Grands-Echézeaux

(2)

Echézeaux

(3)

*In four-bottle and eight-bottle original wooden cases*642 12 bottles *per lot* HK\$160,000-240,000**Domaine de la Romanée-Conti, Montrachet 2008***Grand Cru, Côte de Beaune*643 1 bottle *per lot* HK\$30,000-45,000**Domaine de la Romanée-Conti, Romanée-Conti 2008***Grand Cru, Côte de Nuits*644 1 bottle *per lot* HK\$75,000-110,000**Domaine de la Romanée-Conti, Romanée-Conti 2012***Grand Cru, Côte de Nuits**In original wooden case*645 1 bottle *per lot* HK\$80,000-120,000**Domaine de la Romanée-Conti, Romanée-Conti 2013***Grand Cru, Côte de Nuits**In original wooden case*646 1 bottle *per lot* HK\$80,000-120,000**Domaine de la Romanée-Conti, La Tâche 2011***Grand Cru, Côte de Nuits**In banded original wooden case*647 6 bottles *per lot* HK\$95,000-140,000



Domaine de la Romanée-Conti, La Tâche 2012
Grand Cru, Côte de Nuits
 648 2 bottles per lot HK\$30,000-45,000

Domaine de la Romanée-Conti, La Tâche 2013
Grand Cru, Côte de Nuits
 649 2 bottles per lot HK\$30,000-45,000

Domaine de la Romanée-Conti, Richebourg 2003
Grand Cru, Côte de Nuits
In original wooden case
 650 3 bottles per lot HK\$32,000-48,000

Domaine de la Romanée-Conti, Richebourg 2009
Grand Cru, Côte de Nuits
In original wooden case
 651 6 bottles per lot HK\$70,000-100,000

Domaine de la Romanée-Conti, Richebourg 2011
Grand Cru, Côte de Nuits
In six-bottle original wooden case
 652 3 bottles per lot HK\$28,000-40,000

Domaine de la Romanée-Conti, Richebourg 2012
Grand Cru, Côte de Nuits
 653 2 bottles per lot HK\$20,000-30,000

Domaine de la Romanée-Conti, Richebourg 2013
Grand Cru, Côte de Nuits
 654 2 bottles per lot HK\$20,000-30,000

Domaine de la Romanée-Conti, Romanée-Saint-Vivant 2009
Grand Cru, Côte de Nuits
 655 12 bottles per lot HK\$110,000-160,000



Lots 649, 654, 658, 663 and 667

Domaine de la Romanée-Conti, Romanée-Saint-Vivant 2011
Grand Cru, Côte de Nuits
In banded original wooden case
 656 6 bottles *per lot* HK\$48,000-75,000

Domaine de la Romanée-Conti, Romanée-Saint-Vivant 2012
Grand Cru, Côte de Nuits
 657 3 bottles *per lot* HK\$24,000-38,000

Domaine de la Romanée-Conti, Romanée-Saint-Vivant 2013
Grand Cru, Côte de Nuits
 658 3 bottles *per lot* HK\$24,000-38,000

Domaine de la Romanée-Conti, Echézeaux 1999
Grand Cru, Côte de Nuits
In banded six-bottle original wooden cases
 659 12 bottles *per lot* HK\$95,000-150,000

Domaine de la Romanée-Conti, Echézeaux 2010
Grand Cru, Côte de Nuits
In original wooden case
 660 12 bottles *per lot* HK\$95,000-150,000

Domaine de la Romanée-Conti, Echézeaux 2011
Grand Cru, Côte de Nuits
In banded original wooden case
 661 6 bottles *per lot* HK\$40,000-60,000

Domaine de la Romanée-Conti, Echézeaux 2012
Grand Cru, Côte de Nuits
 662 2 bottles *per lot* HK\$13,000-19,000

Domaine de la Romanée-Conti, Echézeaux 2013
Grand Cru, Côte de Nuits
 663 2 bottles *per lot* HK\$13,000-19,000

Domaine de la Romanée-Conti, Grands- Echézeaux 2002
Grand Cru, Côte de Nuits
In three-bottle original wooden cases
 664 6 bottles *per lot* HK\$55,000-80,000

Domaine de la Romanée-Conti, Grands- Echézeaux 2011
Grand Cru, Côte de Nuits
In banded original wooden case
 665 6 bottles *per lot* HK\$42,000-65,000

Domaine de la Romanée-Conti, Grands- Echézeaux 2012
Grand Cru, Côte de Nuits
 666 2 bottles *per lot* HK\$13,000-20,000

Domaine de la Romanée-Conti, Grands- Echézeaux 2013
Grand Cru, Côte de Nuits
 667 2 bottles *per lot* HK\$14,000-20,000

Domaine de la Romanée-Conti, Vosne-Romanée Cuvée Duvault-Bloch 2008
1er Cru, Côte de Nuits
 668 3 bottles *per lot* HK\$17,000-26,000

Domaine de la Romanée-Conti, Vosne-Romanée Cuvée Duvault-Bloch 2009
1er Cru, Côte de Nuits
Three in banded three-bottle original wooden case. Four in six-bottle original wooden case
 669 7 bottles *per lot* HK\$42,000-65,000

Domaine d'Eugenie, Clos de Vougeot 2009
Grand Cru, Côte de Nuits
In six-bottle original wooden cases
 670 12 bottles *per lot* HK\$17,000-24,000

Mixed 2009 & 2010 Domaine d'Eugenie, Grands-Echézeaux 2009
In original wooden case (6)
2010 (3)
 671 9 bottles *per lot* HK\$15,000-22,000

Mixed Domaine d'Eugenie Grands-Echézeaux 2007 (5)
Clos de Vougeot 2010 (6)
In original wooden cases
 672 11 bottles *per lot* HK\$16,000-26,000

Domaine Duroche, Chambertin Clos de Bèze 2009
Grand Cru, Côte de Nuits
In original carton
 673 6 bottles *per lot* HK\$6,500-9,500

Drouhin Laroze, Chambertin Clos de Bèze 2012
Grand Cru, Côte de Nuits
In original carton
 674 12 bottles *per lot* HK\$9,000-14,000

Drouhin Laroze, Chambertin Clos de Bèze 2013
Grand Cru, Côte de Nuits
In original carton
 675 12 bottles per lot HK\$8,500-13,000

Mixed Domaine Drouhin-Laroze & Joseph Drouhin 2010
Domaine Drouhin-Laroze, Chambertin Clos de Bèze (6)
Joseph Drouhin, Beaune Clos des Mouches (12)
In original cartons
 676 18 bottles per lot HK\$11,000-17,000

Mixed 2009 Domaine Dujac
Bonnes Mares (5)
Clos St. Denis (5)
Echézeaux (3)
 677 13 bottles per lot HK\$50,000-70,000

Emmanuel Rouget, Echézeaux 1997
Grand Cru, Côte de Nuits
One badly stained label
 678 3 bottles per lot HK\$10,000-15,000

Emmanuel Rouget, Vosne-Romanée Cros Parantoux 1997
1er Cru, Côte de Nuits
 679 3 bottles per lot HK\$18,000-26,000

Emmanuel Rouget, Vosne-Romanée Les Beaumonts 2009
1er Cru, Côte de Nuits
In original carton
 680 12 bottles per lot HK\$26,000-40,000

Mixed Faiveley White
Joseph Faiveley Chablis Vaudesir 2009
In original wooden case without lid. Two slightly damaged labels (12)
Domaine Faiveley Corton-Charlemagne 2014 (6)
In banded original wooden case
 681 18 bottles per lot HK\$8,000-13,000

Joseph Faiveley, Chambertin Clos de Bèze 2002
Grand Cru, Côte de Nuits
In original wooden case
 682 6 bottles per lot HK\$9,500-14,000

Domaine Faiveley, Chambertin Clos de Bèze 2010
Grand Cru, Côte de Nuits
In original wooden case
 683 6 bottles per lot HK\$10,000-15,000

Domaine Faiveley, Chambertin Clos de Bèze 2014
Grand Cru, Côte de Nuits
In banded original wooden case
 684 6 bottles per lot HK\$9,500-14,000

Domaine Faiveley, Chambertin Clos de Bèze Ouvrées Rodin 2011
Grand Cru, Côte de Nuits
In original wooden case, banded prior to inspection
 685 6 bottles per lot HK\$20,000-32,000

Domaine Faiveley, Chambertin Clos de Bèze Ouvrées Rodin 2013
Grand Cru, Côte de Nuits
In banded original wooden case
 686 6 bottles per lot HK\$20,000-32,000



	Mixed Domaine Faiveley Chambertin Clos de Bèze Ouvrées Rodin 2010				
	<i>In six-bottle original wooden case</i>	(3)			
687	2014	(3)			
	6 bottles		<i>per lot</i>	HK\$22,000-32,000	
	Mixed 1999 & 2013 Faiveley, Mazis Chambertin				
	Joseph Faiveley 1999	(12)			
	Domaine Faiveley 2013	(6)			
	<i>In original wooden cases</i>				
688	18 bottles		<i>per lot</i>	HK\$17,000-26,000	
	Mixed 2010 & 2011 Domaine Faiveley, Mazis Chambertin				
	2010	(6)			
	2011	(12)			
	<i>In six-bottle original wooden cases</i>				
689	18 bottles		<i>per lot</i>	HK\$13,000-19,000	
	Domaine Faiveley, Musigny 2011				
	<i>Grand Cru, Côte de Nuits</i>				
	<i>In original wooden case</i>				
690	1 bottle		<i>per lot</i>	HK\$13,000-19,000	
	Mixed 2014 Domaine Faiveley				
	Chambolle-Musigny Les Amoureuses				
	<i>In original carton</i>	(6)			
	Clos de Vougeot				
	<i>In banded original wooden case</i>	(6)			
	Corton Clos des Cortons				
	<i>In banded original wooden case</i>	(6)			
691	18 bottles		<i>per lot</i>	HK\$15,000-24,000	
	Mixed 2014 Domaine Faiveley				
	Echézeaux	(6)			
	Latricières-Chambertin	(6)			
	Mazis-Chambertin	(6)			
	<i>In banded original wooden cases</i>				
692	18 bottles		<i>per lot</i>	HK\$13,000-20,000	
	Follin Arbelet, Romanée-Saint-Vivant 2005				
	<i>Grand Cru, Côte de Nuits</i>				
	<i>In original cartons</i>				
693	12 bottles		<i>per lot</i>	HK\$22,000-35,000	
694	12 "				
	Follin Arbelet, Romanée-Saint-Vivant 2012				
	<i>Grand Cru, Côte de Nuits</i>				
	<i>In original carton</i>				
695	6 bottles		<i>per lot</i>	HK\$11,000-17,000	
	Follin Arbelet, Romanée-Saint-Vivant 2013				
	<i>Grand Cru, Côte de Nuits</i>				
	<i>In original carton</i>				
696	6 bottles		<i>per lot</i>	HK\$10,000-15,000	
	Domaine Fourrier, Gevrey-Chambertin Champeaux 2004				
	<i>1er Cru, Côte de Nuits</i>				
	<i>In original cartons</i>				
697	18 bottles		<i>per lot</i>	HK\$13,000-19,000	
	Mixed Domaine Fourrier				
	Morey-Saint-Denis Clos Sorbe 2011	(6)			
	Gevrey-Chambertin 2014	(12)			
	<i>In original cartons</i>				
698	18 bottles		<i>per lot</i>	HK\$9,000-14,000	
	François Lamarche, Echézeaux 2009				
	<i>Grand Cru, Côte de Nuits</i>				
	<i>In original wooden case</i>				
699	12 bottles		<i>per lot</i>	HK\$10,000-15,000	
	François Lamarche, La Grande Rue 2010				
	<i>Grand Cru, Côte de Nuits</i>				
	<i>In original wooden case</i>				
700	12 bottles		<i>per lot</i>	HK\$28,000-45,000	
	Mixed François Lamarche & Chantal Remy				
	François Lamarche, Vosne-Romanée Les Suchots 2011	(6)			
	Chantal Remy, Latricières-Chambertin 2013	(6)			
	<i>In original cartons</i>				
701	12 bottles		<i>per lot</i>	HK\$7,500-12,000	
	Georges Jayer, Nuits-Saint-Georges 2005				
	<i>Côte de Nuits</i>				
	<i>In original carton. Élevé et vinifié par E. Rouget</i>				
702	11 bottles		<i>per lot</i>	HK\$10,000-16,000	
	Mixed 2012 & 2013 Georges Lignier Bonnes Mares				
	2012	(6)			
	2013	(6)			
	<i>In original cartons</i>				
703	12 bottles		<i>per lot</i>	HK\$9,500-14,000	
	Mixed 2012 & 2013 Georges Lignier Clos de la Roche				
	2012	(6)			
	2013	(6)			
	<i>In original cartons</i>				
704	12 bottles		<i>per lot</i>	HK\$8,500-13,000	

	Mixed Georges Lignier	
	Clos-Saint-Denis 2012	(6)
	Clos-Saint-Denis 2013	(6)
	Gevrey Chambertin Les Combottes 2013	(6)
	Morey-Saint-Denis Clos des Ormes 2013	(6)
	<i>In original cartons</i>	
705	24 bottles	per lot HK\$10,000-16,000

Domaine Georges Roumier

In 1924 Georges Roumier took over the Domaine which had previously belonged to his wife's family in Chambolle Musigny. The Domaine was expanded with acquisitions such as, Le Clos de la Bussière in Morey St Denis in 1953 and in Musigny in 1978. Today the Domaine is run by Christophe Roumier who has been making the wines since 1982.

Domaine Georges Roumier owns approximately 13 hectares of vineyards spread over nine separate appellations. Their holdings include 0.1 hectares of Le Musigny, 1.39 hectares of Bonnes-Mares and 0.2 hectares of Corton Charlemagne. The vines are cultivated without using weed killers or fertilizers.

The grapes are hand-harvested before a rigorous sorting and partial destemming. Both pre and post-fermentation macerations are used, in order to allow the natural yeasts to develop with the former, and to encourage the development of fleshier tannins in the latter. The wines are aged in oak; the proportion of new oak varies from 15% to 50% depending on the wine and vintage.

Three Grand Cru wines are produced; Bonnes-Mares, Musigny and Corton-Charlemagne (Clos de Vougeot was last produced in 1996) as well as a number of Premier Cru wines, such as Chambolle-Musigny, Les Cras and Les Amoureuses and the Monopole in Morey-Saint-Denis, Clos de la Bussière. Their wines are well-structured and harmonious with significant ageing potential. Bonnes-Mares is in particularly high demand as it is one of the finest wines produced in Burgundy.

喬治·盧米耶酒莊

1924年喬治·盧米耶接管其妻子家族擁有的這個香波-木樺尼村的酒莊。酒莊規模不短擴大，於1953年購入了莫雷-聖但尼村的貝熙業園，於1978年購入特級田木樺尼園。酒莊目前由克利斯朵夫·盧米耶運營，他自1982年接手釀酒工作。

喬治·盧米耶酒莊目前擁有13公頃的土地，分布在9個不同的葡萄園中。最珍貴的，莫過於0.1公頃的木樺尼園、1.39公頃的波瑪園和0.2公頃的哥頓-查理曼園。酒莊完全不適用殺蟲劑或者化肥。

葡萄完全採用人工採摘，並且經過嚴格的揀選和部分除梗。發酵前後均進行浸漬，以促進發酵前酵母的增殖，以及發酵後丹寧的柔順。葡萄酒在橡木桶中陳釀，根據年份和葡萄園的不同，使用15-50%的新橡木桶。

酒莊一共有三片特級田：木樺尼園、波瑪園和哥頓-查理曼園（梧玖園最後一次釀造於1996年）。酒莊的一級田包括：香波-木樺尼村的格拉斯園和愛侶園，莫雷-聖但尼村的獨佔園貝熙業園。這些酒無一不結構完整、圓潤和諧，並且極具陳年潛力。波瑪園是其中的佼佼者，引起品質出眾而炙手可熱。

	Georges Roumier, Musigny 2012	
	<i>Grand Cru, Côte de Nuits</i>	
706	1 bottle	per lot HK\$35,000-50,000

	Georges Roumier, Musigny 2013	
	<i>Grand Cru, Côte de Nuits</i>	
	<i>In original wooden case</i>	
707	1 bottle	per lot HK\$32,000-48,000

	Mixed G. Roumier Bonnes Mares	
	2009	(1)
	2010	
	<i>Very slightly stained label</i>	(1)
708	2 bottles	per lot HK\$11,000-15,000

	Georges Roumier, Chambolle-Musigny Les Amoureuses 2012	
	<i>1er Cru, Côte de Nuits</i>	
	<i>In original carton</i>	
709	3 bottles	per lot HK\$30,000-45,000

	Georges Roumier, Chambolle-Musigny Les Amoureuses 2013	
	<i>1er Cru, Côte de Nuits</i>	
	<i>In original carton</i>	
710	3 bottles	per lot HK\$24,000-35,000

	Georges Roumier, Morey-Saint-Denis Clos de la Bussière 2009	
	<i>1er Cru, Côte de Nuits</i>	
	<i>In original carton</i>	
711	12 bottles	per lot HK\$11,000-16,000

	Mixed Georges Roumier	
	Morey-Saint-Denis Clos de la Bussière 2008	(6)
	Chambolle-Musigny 2008	(6)
	Chambolle-Musigny 2009	(6)
	<i>In original cartons</i>	
712	18 bottles	per lot HK\$17,000-26,000

	Georges Roumier, Chambolle-Musigny 2009	
	<i>Côte de Nuits</i>	
	<i>In original carton</i>	
713	12 bottles	per lot HK\$13,000-19,000

	Mixed 2010-2012 Georges Roumier Chambolle Musigny	
	2010	(6)
	2011	(6)
	2012	(6)
	<i>In original cartons</i>	
714	18 bottles	per lot HK\$15,000-24,000

	Mixed Gros Frère et Sœur, Clos Vougeot Musigni	
	2009	(3)
	2011	
	<i>In six-bottle original cartons</i>	(12)
715	15 bottles	per lot HK\$12,000-18,000



Mixed 2009 & 2011 Gros Frère et Sœur, Grands Echézeaux 2009 (3)
2011 (6)
In original carton (6)
 716 9 bottles per lot HK\$10,000-15,000

Domaine Henri Gouges, Nuits St. Georges Les St. Georges 2012
1er Cru, Côte de Nuits
In original carton
 717 12 bottles per lot HK\$9,000-14,000

Domaine Henri Gouges, Nuits St. Georges Les St. Georges 2013
1er Cru, Côte de Nuits
In original carton
 718 12 bottles per lot HK\$8,500-13,000

Domaine de Montille, Corton Pougets 2005
Grand Cru, Côte de Beaune
Twelve in original carton
 719 14 bottles per lot HK\$9,500-14,000

Mixed Domaine de Montille

Beaune 1er Cru Grèves 2005 (4)
Beaune 1er Cru Les Sizies 2005 (9)
Puligny Montrachet Les Caillerets 2005 (2)
Volnay Les Taillepieds 2010 (6)
In original carton (6)
 720 21 bottles per lot HK\$10,000-15,000

Mixed 2005 Domaine de Montille

Pommard Les Rugiens (2)
Pommard Les Pézerolles (2)
Volnay Champans (2)
Volnay Les Brouillards (2)
Volnay Les Taillepieds (2)
Volnay Les Mitans (2)
 721 12 bottles per lot HK\$7,500-11,000

Domaine Jacques-Frédéric Mugnier

Domaine Jacques-Frédéric Mugnier is a family owned Domaine founded in 1863 by Frédéric Mugnier with the purchase of the Château de Chambolle-Musigny from the Marey-Mong family and vines in Chambolle-Musigny and Nuits-Saint-Georges.

Today the Domaine, based in Chambolle-Musigny is run by Frédéric Mugnier. In 2004 Frédéric Mugnier took back the monopole Clos de la Maréchale in Nuits-St.-Georges which had been leased to Domaine Faiveley for the 50 previous years.

The Domaine owns 13.5 hectares of vineyards, including 1.13 hectares of Le Musigny and 0.35 hectares of Bonnes-Mares and the 10 hectares of Clos de la Maréchale in Nuits Saint Georges and 4 hectares in Chambolle-Musigny.

Frédéric Mugnier's approach to both viticulture and wine-making is aimed at preserving in the wines the purest expression of nature with minimal interference from technological practices. JF Mugnier is perhaps best known for their superlative Musigny, but they should also be praised for their Bonnes Mares, Chambolle-Musigny Premier Cru Les Amoureuses, Clos de la Maréchale and a range of other excellent wines from Chambolle and Nuits.

慕尼耶酒莊

弗德里克·慕尼耶於 1863 年買下 兩 - 蒙日家族的香波蜜思妮城堡，以及位於香波蜜思妮和夜聖喬治產品的葡萄園，創立家族經營的慕尼耶酒莊。

位於香波蜜思妮產區的酒莊現時由其後人弗德里克·慕尼耶打理。於 2004 年，弗德里克收回位於夜聖喬治區、出租予法 酒庄 50 年的瑪蕾莎一級園。

酒莊的葡萄園佔地 13.5 公頃，包括 1.13 公頃的蜜思妮葡萄園、0.35 公頃的邦馬爾葡萄園、位於夜聖喬治的 10 公頃瑪蕾莎一級園，以及 4 公頃的香波蜜思妮村葡萄園。

弗德里克在栽種葡萄及釀酒的過程中致力減少使用現代科技，務求保留葡萄酒最天然的風味。慕尼耶酒莊以頂級的蜜思妮佳釀聞名，而邦馬爾、香波蜜思妮一級園愛侶園、瑪蕾莎園，以及香波和夜丘區出品的其他佳釀，也同樣享負盛名。

Mixed 2009 & 2010 J.F. Mugnier Musigny 2009 (1)
2010 (1)
 722 2 bottles per lot HK\$18,000-28,000

J.F. Mugnier, Musigny 2012
Grand Cru, Côte de Nuits
In banded original carton
 723 3 bottles per lot HK\$28,000-42,000

J.F. Mugnier, Bonnes Mares 2005
Grand Cru, Côte de Nuits
One stained label
 724 5 bottles per lot HK\$26,000-38,000

Mixed 2009 & 2010 J.F. Mugnier, Chambolle-Musigny Les Amoureuses 2009 (1)
2010 (1)
 725 2 bottles per lot HK\$13,000-20,000

J.F. Mugnier, Chambolle-Musigny Les Amoureuses 2013
1er Cru, Côte de Nuits
In original carton
 726 6 bottles *per lot* HK\$26,000-40,000

J.F. Mugnier, Chambolle-Musigny 2009
Côte de Nuits
In six-bottle original wooden cases
 727 18 bottles *per lot* HK\$15,000-22,000

Mixed 2009 & 2010 J.F. Mugnier Chambolle-Musigny
Chambolle-Musigny Les Fuées 2009 (1)
Chambolle-Musigny Les Fuées 2010 (1)
Chambolle-Musigny 2010 (9)
Six in original wooden case
 728 11 bottles *per lot* HK\$11,000-17,000

Mixed 2011-2013 J.F. Mugnier Chambolle-Musigny
2011 (6)
2012 (6)
2013 (6)
In original cartons
 729 18 bottles *per lot* HK\$13,000-20,000

Mixed J.F. Mugnier Nuits St. Georges Clos de la Maréchale red & white
Nuits St. Georges Clos de la Maréchale 2005 (2)
Nuits St. Georges Clos de la Maréchale 2006 (2)
Nuits St. Georges Clos de la Maréchale 2007 (2)
Nuits St. Georges Clos de la Maréchale 2008 (2)
Nuits St. Georges Clos de la Maréchale 2009 (8)
Nuits St. Georges Clos de la Maréchale 2010 (5)
Nuits St. Georges Clos de la Maréchale Blanc 2007 (2)
Nuits St. Georges Clos de la Maréchale Blanc 2010 (1)
 730 24 bottles *per lot* HK\$14,000-22,000

Mixed 2010 J.F. Mugnier
Nuits-Saint-Georges Clos de la Maréchale magnum (1)
Musigny (2)
Chambolle Musigny Les Amoureuses (2)
Chambolle Musigny Les Fuées (2)
 731 1 magnum and 6 bottles *per lot* HK\$32,000-48,000

Jacques Prieur, Musigny 2007
Grand Cru, Côte de Nuits
In original carton
 732 6 bottles *per lot* HK\$13,000-20,000

Jacques Prieur, Musigny 2008
Grand Cru, Côte de Nuits
In original carton
 733 6 bottles *per lot* HK\$12,000-18,000

Jacques Prieur, Musigny 2009
Grand Cru, Côte de Nuits
In original carton
 734 6 bottles *per lot* HK\$15,000-22,000

Jean Grivot, Vosne-Romanée Les Beaumonts 2002
1er Cru, Côte de Nuits
In original carton
 735 12 bottles *per lot* HK\$12,000-18,000

Jean-Louis Trapet, Chambertin 2008
Grand Cru, Côte de Nuits
In six-bottle original cartons
 736 12 bottles *per lot* HK\$11,000-17,000



Lot 734

Jean-Pierre Mathieu, Charmes-Chambertin Aux Mazoyeres 2011

*Grand Cru, Côte de Nuits
In six-bottle original cartons*

737 12 bottles per lot HK\$28,000-42,000

Joseph Drouhin

With its 73 hectares, Domaine Joseph Drouhin is one of the largest estates in Burgundy. It owns vineyards throughout all of Burgundy: Chablis (38 hectares), Côte de Nuits and Côte de Beaune, (32 hectares), Côte Chalonnaise (3 hectares).

The Domaine was put together through the years, thanks to judicious purchases and agreements between families. Some vineyards are among the most famous in Burgundy, such as Clos des Mouches, Montrachet Marquis de Laguiche, Musigny, Clos de Vougeot, and Corton-Charlemagne to name a few.

The Domaine cherishes the ideal of elegance and perfection. The "Joseph Drouhin style" marries balance, harmony, finesse and character. This combination of riches provides infinite pleasure.

The wines are recognizable for their great purity of taste. Young, they possess fruity and enticing aromas; with age, wines from great vineyards and appellations acquire a sumptuous complexity.

Some wines are able to age forty years or more. They then become true masterpieces of harmony and excellence, graced by the most entrancing kaleidoscope of aromas.

Today, the House of Joseph Drouhin is run by Joseph's four grandchildren, born between 1961 and 1968. They grew up practically in the vineyards and cellars. They have acquired their knowledge with their father Robert Drouhin at their side. Each one has his or her role to play and each shares the same passion for vine and wine. From vintage to vintage, they perpetuate the tradition and do not shy away from innovation in their search for elegance and perfection, the hallmark of Maison Joseph Drouhin.

約瑟夫·杜魯安酒莊

約瑟夫·杜魯安酒莊是勃艮第規模最大的酒莊之一，佔地 73 公頃。酒莊的葡萄園遍佈勃艮第，包括佔地 38 公頃的夏布利、佔地 32 公頃的夜丘及伯恩丘，以及佔地 3 公頃的夏隆內丘。

多年來，杜魯安家族審慎收購不同的葡萄園，並與其他家族達成協議，成就今日的酒莊，當中不乏勃艮第的頂級葡萄園，例如蜂蜜園、蒙哈榭拉古奇侯爵園、慕西尼、梧玖及哥頓·查理曼葡萄園。

約瑟夫·杜魯安酒莊頌揚優雅完美的葡萄酒。「約瑟夫·杜魯安風格」講求葡萄酒的平衡、和諧、細膩與個性，締造令人難忘的享受。

約瑟夫·杜魯安酒莊的葡萄酒以酒味香醇聞名，新酒散發醉人果香，而源自頂級葡萄園及產區的陳釀更呈現豐富複雜的口感。

部份美釀可陳年逾 40 年，呈現出眾和諧的味道，並散發誘人香氣，堪稱傳世佳釀。

目前，酒莊由約瑟夫四個孫輩經營。他們在 1961 年至 1968 年出生，在葡萄園及酒窖中長大，從小跟隨父親羅伯特·杜魯安學習釀酒。他們各司其職，對葡萄酒及葡萄酒充滿熱誠，承傳釀酒傳統，同時勇於創新，銳意釀造優雅完美的佳釀，延續約瑟夫·杜魯安酒莊的釀酒傳奇。

Joseph Drouhin, Chablis Bougros 2005

*Chablis, Grand Cru
In original cartons*

738 24 bottles per lot HK\$7,500-11,000

Joseph Drouhin, Chablis Les Clos 2008

*Chablis, Grand Cru
In original cartons*

739 24 bottles per lot HK\$8,000-12,000

Joseph Drouhin, Montrachet Marquis de Laguiche 2011

*Grand Cru, Côte de Beaune
In original carton*

740 6 bottles per lot HK\$20,000-30,000

Joseph Drouhin, Montrachet Marquis de Laguiche 2011

*Grand Cru, Côte de Beaune
In original wooden case*

741 12 bottles per lot HK\$40,000-60,000

Joseph Drouhin, Montrachet Marquis de Laguiche 2012

*Grand Cru, Côte de Beaune
In original wooden case*

742 6 bottles per lot HK\$18,000-26,000

Joseph Drouhin, Montrachet Marquis de Laguiche 2013

*Grand Cru, Côte de Beaune
In original wooden cases*

743 6 bottles per lot HK\$17,000-24,000

744 6 "



Lots 740-745

Joseph Drouhin, Montrachet Marquis de Laguiche 2014
Grand Cru, Côte de Beaune
In original wooden case

745 6 bottles *per lot* HK\$19,000-28,000

Joseph Drouhin, Musigny 2004
Grand Cru, Côte de Nuits
In original wooden case

746 12 bottles *per lot* HK\$24,000-38,000

Mixed 2009 Joseph Drouhin Musigny 2009
In original wooden case magnum (1)
2009 (2)

747 1 magnum and 2 bottles *per lot* HK\$20,000-30,000

Joseph Drouhin, Musigny 2011
Grand Cru, Côte de Nuits

748 3 bottles *per lot* HK\$10,000-15,000

Joseph Drouhin, Musigny 2011
Grand Cru, Côte de Nuits
In original wooden case

749 6 bottles *per lot* HK\$20,000-30,000

Joseph Drouhin, Musigny 2012
Grand Cru, Côte de Nuits
In original wooden case

750 6 bottles *per lot* HK\$24,000-38,000

Joseph Drouhin, Chambertin Clos de Bèze 2006
Grand Cru, Côte de Nuits
In original wooden case

751 12 bottles *per lot* HK\$12,000-18,000

Joseph Drouhin, Chambertin Clos de Bèze 2007
Grand Cru, Côte de Nuits

752 12 bottles *per lot* HK\$12,000-18,000

Joseph Drouhin, Chambertin Clos de Bèze 2007
Grand Cru, Côte de Nuits
In original wooden case

753 12 bottles *per lot* HK\$12,000-18,000

Joseph Drouhin, Chambertin Clos de Bèze 2011
Grand Cru, Côte de Nuits
Twelve in original wooden case

754 15 bottles *per lot* HK\$22,000-35,000

Joseph Drouhin, Chambolle-Musigny Les Amoureuses 2008
1er Cru, Côte de Nuits
In original wooden case

755 12 bottles *per lot* HK\$22,000-32,000

Joseph Drouhin, Chambolle-Musigny Les Amoureuses 2009
1er Cru, Côte de Nuits

756 3 bottles *per lot* HK\$6,500-100,000

Mixed 2009 & 2011 Joseph Drouhin Grand Crus Red

Charmes-Chambertin 2009 (2)
Charmes-Chambertin 2011 (2)
Clos de Vougeot 2009 (4)
Clos de Vougeot 2011 (2)
Corton Bressandes 2009 (2)
Corton Bressandes 2011 (1)

757 13 bottles *per lot* HK\$11,000-16,000



Lot 752

Mixed Joseph Drouhin Echézeaux & Grands Echézeaux
Echézeaux 2009 (2)
Grands Echézeaux 2009 (4)
Grands Echézeaux 2011 (1)
758 7 bottles *per lot* HK\$12,000-19,000

Mixed Joseph Drouhin Chambertin Clos de Bèze & Chambolle-Musigny Les Amoureuses
2009 Joseph Drouhin Chambertin Clos de Bèze (2)
2011 Joseph Drouhin Chambertin Clos de Bèze (1)
2009 Joseph Drouhin Chambolle-Musigny Les Amoureuses (2)
2011 Joseph Drouhin Chambolle-Musigny Les Amoureuses (1)
759 6 bottles *per lot* HK\$10,000-15,000

Mixed Joseph Drouhin Grand Crus
Montrachet Marquis de Laguiche 1999 (1)
Griotte-Chambertin 2009 (2)
Clos de la Roche 2011 (2)
Bonnes Mares 2011 (1)
Musigny 2012 (1)
760 7 bottles *per lot* HK\$13,000-20,000

Mixed Joseph Drouhin
Chablis le Clos "Drouhin-Vaudon" 2009 (12)
Beaune Clos des Mouches 2011 (6)
Beaune Clos des Mouches Blanc 2011 (6)
761 24 bottles *per lot* HK\$9,000-14,000

Joseph Roty, Charmes Chambertin Cuvée Vieilles Vignes 2009
Grand Cru, Côte de Nuits
762 12 bottles *per lot* HK\$22,000-32,000

Maison Leroy, Meursault Genevrières 1964
1er Cru, Côte de Beaune
In twelve-bottle original wooden case. Recent release. Two slightly stained labels otherwise excellent appearance. Levels: one 1.5cms, three 2.5cms, two 3cms
763 6 bottles *per lot* HK\$19,000-28,000

Maison Leroy, Meursault Genevrières 1992
1er Cru, Côte de Beaune
Slightly stained labels. Levels 1cm or better
764 5 bottles *per lot* HK\$12,000-18,000

Maison Leroy, Gevrey Chambertin 1er Cru 1985
1er Cru, Côte de Nuits
Signs of old seepage. Slightly stained labels. Levels one 1cm, three 2cms, two 2.5cms
765 6 bottles *per lot* HK\$14,000-20,000

Domaine du Comte Liger-Belair

Domaine du Comte Liger-Belair is a Domaine created at the beginning of the year 2000 by Louis-Michel Liger-Belair, agricultural engineer and oenologist, with those few parcels of vineyards remaining in family hands. In reality, the Domaine is not at all recent; Louis-Michel is renewing two hundred years of family tradition dedicated to the vines and wines of Burgundy in general, and to Vosne-Romanée in particular.

The Liger-Belair family settled in Vosne when Louis Liger-Belair, Napoleonic general, acquired the Château of Vosne in 1815. When the Comte Louis-Charles died, the family's holdings covered more than sixty hectares principally in the Côte de Nuits.

The Comte Henri Liger-Belair, grandson of the Comte Louis-Charles, the eldest child of the family and great grandfather of Louis-Michel died in 1924. He left a wife and ten children in possession of twentyfour hectares of vines and the Château. The Domaine held together until the death of the Comtesse Liger-Belair in 1931. The ten children were still there but two were minors and the law of that era required that all children must be of age in order to distribute the inheritance or the estate must be sold. Three of the family members did not want to wait until the younger children reached legal adulthood and insisted that the entirety of the domaine be put up for sale. It was a sad day on August 31st 1933 at the town hall of Vosne Romanée when the vineyards were auctioned off. The children witnessed the departure from their patrimony of La Tache, Malconsorts, Brulée....However, two of the children, a priest and his brother, the Comte Michel, Louis-Michel's grandfather, banded together to buy back La Romanée, Reignots, and les Chaumes. The vineyards were entrusted to local vigneron, and the wines sold to Burgundian négociants. The Comte Michel died in 1941, during the war before he could redevelop the Domaine. His son, the Comte Henry, Louis Michel's father, enlisted in the army in 1949, pursued a brilliant career and rose to the rank of general following in the footsteps of his ancestor six generations earlier. He managed the Domaine leaving vineyard work to sharecroppers, and selling the finished wine to various shippers.

When he was eight years old Louis-Michel informed his parents that he intended to live in Vosne-Romanée when he grew up. His father informed Louis-Michel that he could not take charge of the domaine unless he became an engineer. Therefore, Louis-Michel majored in science, became a qualified agricultural engineer with a degree in commerce, and a diploma in oenology from the University of Dijon. He created his domaine in 2000 by taking back 1.5 hectares of vineyards (Vosne-Romanée La Colombière, Clos du Château, 1er Cru Les Chaumes), and in 2002 he recovered another 1.6 hectares (Vosne- Romanée 1er Cru Aux Reignots, La Romanée). In 2006, he rented 5.5 hectares more, including a large parcel of Echézeaux, Vosne-Romanée 1er Cru Les Suchots, Les Petits Monts and Les Brûlées, Nuits St. Georges 1er Cru Aux Cras, Vosne-Romanée and Nuits St. Georges. In 2012, he had the opportunity to buy a "Clos" Monopole in Nuits St. Georges Premier Cru, called Clos des Grandes Vignes. This addition of 2.2 hectares (5.2 acres) is mainly planted with Pinot Noir, to produce red wines, but has also a tiny part of Chardonnay, which will be the first white wine for Comte Liger-Belair.

With his wife, Constance, and their three children – Henry (2002), Brune (2003), and Pia (2006), he now manages 10.5 hectares of vines in Vosne-Romanée, Nuits St. Georges, and Flagey Echézeaux. The Domaine is run fully certified organically and biodynamically.

貝萊爾伯爵酒莊

農業工程師兼釀酒師路易士·米歇爾·利熱貝萊爾以家族僅餘的幾個葡萄園，於2000年初創立貝萊爾伯爵酒莊。事實上，貝萊爾伯爵酒莊並非新晉酒莊，而是復興家族已有兩百年種植葡萄和釀酒的傳統，家族主要釀造勃艮第葡萄酒，特別以沃恩·羅曼尼村的佳釀聞名。

於1815年，當時為拿破崙麾下將軍的路易士·利熱貝萊爾買下沃恩酒莊，利熱貝萊爾家族便在此定居。路易士·查理斯伯爵逝世時，家族擁有的葡萄園已超過60公頃，主要位於夜丘區。

亨利·利熱貝萊爾伯爵是路易士·查理斯的長孫，亦是路易士·米歇爾的曾祖父。他於1924年逝世，遺下妻子和十名子女，還有24公頃的葡萄園及酒莊。當裡格貝雷伯爵夫人於1931年逝世時，雖然十名子女仍然健在，但由於其中二人尚未成年，而當時的法律規定所有繼承人必須成年才可繼承遺產，否則必須賣掉財產。由於其中三位成員不想等待弟妹長大至法定年齡，堅持賣掉整個酒莊，因此在1933年8月31日於沃恩·羅曼尼市政廳舉行的拍賣會上，家族將祖傳的拉塔希園、馬康索園及布蕾園等——拍賣。不過，其中兩名家族成員朱斯特牧師和哥哥米歇爾伯爵聯手買回羅曼尼園、雷格諾園及修慕園，並將這些葡萄園交由當地的種植者打理，生產的葡萄酒則售予勃艮第的酒商。可惜米歇爾伯爵還未成功重振酒莊，便不幸於1941年戰爭期間逝世，他的兒子亨利伯爵（即路易士·米歇爾的父親）於1949年參軍，取得輝煌成就，與六代前的祖先一樣晉升至將軍。他將酒莊的葡萄園交給佃農打理，並將葡萄酒交由不同酒商銷售。

路易士·米歇爾八歲時，向父母表示長大後要在沃恩·羅曼尼定居，但父親說如果要接管酒莊，必須先成為工程師。因此，路易士·米歇爾在大學時主修科學，為合資格的農業工程師，並持有商業學位和第戎大學釀酒學文憑。他於2000年取回1.5公頃的葡萄園（沃恩·羅曼尼哥倫比爾園、城堡園及修慕一級園），創立自己的酒莊。2002年，他收回另一批1.6公頃的葡萄園（沃恩·羅曼尼雷格諾一級園及羅曼尼園）。2006年，他再租下5.5公頃葡萄園，包括一大幅依瑟索園、沃恩·羅曼尼蘇修一級園、小曼特園和布蕾園、夜聖喬治奧格拉斯一級園，以及沃恩·羅曼尼和夜聖喬治葡萄園。他於2012年買下夜聖喬治區一幅2.2公頃（5.2英畝）的一級獨佔園，命名為大維尼園，主要種

植釀造紅酒的黑皮諾葡萄，小部分園地則種植霞多麗，將會用於釀製酒莊的首批白酒。路易士·米歇爾與妻子康斯坦絲育有三名子女，分別為亨利（2002）、布魯內（2003）及皮婭（2006）。目前酒莊共有10.5公頃葡萄園，遍佈沃恩·羅曼尼、夜聖喬治區及法拉傑埃雪索村。酒莊以全有機及生物動力法種植葡萄，並獲得認證。

Domaine du Comte Liger-Belair, La Romanée 2013

Grand Cru, Côte de Nuits

In three-bottle original wooden cases

766 6 bottles per lot HK\$95,000-140,000

Domaine du Comte Liger-Belair, La Romanée 2014

Grand Cru, Côte de Nuits

In original wooden case

767 3 bottles per lot HK\$48,000-70,000

Domaine du Comte Liger-Belair, Nuits St. Georges Aux Lavières 2013

Côte de Nuits

In original wooden case

768 6 bottles per lot HK\$12,000-18,000

Domaine du Comte Liger-Belair, Nuits St. Georges Aux Lavières 2014

Côte de Nuits

In original wooden case

769 6 bottles per lot HK\$12,000-18,000

Domaine du Comte Liger-Belair, Vosne Romanée Aux Reignots 2005

1er Cru, Côte de Nuits

770 4 bottles per lot HK\$17,000-24,000

Domaine du Comte Liger-Belair, Vosne Romanée Clos du Château 2013

Côte de Nuits

In original wooden case

771 6 bottles per lot HK\$12,000-18,000

Domaine du Comte Liger-Belair, Vosne Romanée Clos du Château 2014

Côte de Nuits

In original wooden case

772 6 bottles per lot HK\$10,000-16,000

Domaine du Comte Liger-Belair, Vosne Romanée 2008

Côte de Nuits

Slightly stained labels

773 12 bottles per lot HK\$13,000-19,000



Lot 773

Louis Jadot, Chambertin Clos de Bèze 2007
Grand Cru, Côte de Nuits
In six-magnum original cartons

774 7 magnums *per lot* HK\$17,000-24,000

Louis Jadot, Musigny 2007
Grand Cru, Côte de Nuits
In six-bottle original wooden cases

775 18 bottles *per lot* HK\$42,000-65,000

Louis Jadot, Musigny 2008
Grand Cru, Côte de Nuits
In original wooden case

776 6 bottles *per lot* HK\$16,000-24,000

Mixed 2009 & 2010 Louis Jadot, Grands-Echézeaux
2009 (6)
2010 (6)
In original wooden cases

777 12 bottles *per lot* HK\$16,000-24,000

Mixed Louis Jadot
Gevrey Chambertin Les Cazetiers 1999
In twelve-bottle original wooden case (6)
Grands-Echézeaux 2005
US import slip labels (3)

778 9 bottles *per lot* HK\$9,500-14,000

Louis Remy, Chambertin 2005
Grand Cru, Côte de Nuits
In original carton

779 12 bottles *per lot* HK\$11,000-16,000

Louis Remy, Latricières-Chambertin 2005
Grand Cru, Côte de Nuits
In original carton

780 12 bottles *per lot* HK\$9,500-14,000

Louis Remy, Latricières-Chambertin 2006
Grand Cru, Côte de Nuits
In original cartons

781 24 bottles *per lot* HK\$16,000-24,000

Lucien Le Moine, Clos St. Denis 2008
Grand Cru, Côte de Nuits
In six-bottle original cartons

782 12 bottles *per lot* HK\$11,000-17,000

Lucien Le Moine, Clos St. Denis 2010
Grand Cru, Côte de Nuits
In six-bottle original cartons, one damaged

783 12 bottles *per lot* HK\$10,000-15,000

Mixed Lucien Le Moine
Clos de la Roche 2005
In original carton (6)
Clos St. Denis 2009
In damaged original carton (6)

784 12 bottles *per lot* HK\$15,000-22,000

Mixed Marius Delarche
Corton-Charlemagne 2004
In original carton (12)
Corton-Renardes 2005 (6)
Corton-Renardes 2006 (6)

785 24 bottles *per lot* HK\$11,000-16,000

Mixed 2005 & 2013 Marquis d'Angerville Volnay Champans
2005 (12)
2013 (6)
In original cartons

786 18 bottles *per lot* HK\$14,000-22,000

Mommessin, Clos de Tart 2005
Grand Cru, Côte de Nuits
In original wooden case

787 3 magnums *per lot* HK\$15,000-22,000

Mixed Méo-Camuzet & Nicolas Potel
Méo-Camuzet, Echézeaux 2002
Stained label. US import slip label (1)
Nicolas Potel, Bonnes Mares 2006
In original wooden case (6)

788 7 bottles *per lot* HK\$6,500-11,000

Mixed 2012 Olivier Bernstein Grand Crus
Bonnes Mares (6)
Charmes Chambertin (6)
Clos de la Roche (6)
In original wooden cases

789 18 bottles *per lot* HK\$26,000-40,000

Mixed Olivier Bernstein
Mazis Chambertin 2011 (6)
Chambolle-Musigny Les Lavrottes 2013 (6)
In original wooden cases

790 12 bottles *per lot* HK\$12,000-18,000

Mixed Olivier Bernstein Gevrey-Chambertin**Olivier Bernstein Gevrey-Chambertin 2011***In original carton* (6)**Gevrey-Chambertin Les Cazetiers 2012***In six-bottle original wooden cases* (12)**Gevrey Chambertin Les Champeaux 2013***In original wooden case* (6)791 24 bottles *per lot* HK\$16,000-24,000**Patrice Rion, Chambolle-Musigny Les Amoureuses 2006***1er Cru, Côte de Nuits**In original carton*792 12 bottles *per lot* HK\$13,000-19,000**Patrice Rion, Chambolle-Musigny Les Amoureuses 2009***1er Cru, Côte de Nuits**In six-bottle original cartons*793 12 bottles *per lot* HK\$15,000-22,000**Mixed 1999 & 2009 Pierre Damoy Chambertin****Pierre Damoy Chambertin 1999***In original carton* (12)**Pierre Damoy Chambertin 2009***In original carton* (6)794 18 bottles *per lot* HK\$19,000-28,000**Pierre Damoy, Chambertin 2010***Grand Cru, Côte de Nuits**In original carton*795 12 bottles *per lot* HK\$15,000-22,000**Pierre Damoy, Chambertin Clos de Bèze 2002***Grand Cru, Côte de Nuits*796 10 bottles *per lot* HK\$12,000-18,000**Mixed Pierre Damoy****Chambertin Clos de Bèze Reserve 2009***In original carton* (2)**Gevrey-Chambertin Clos Tamisot 2009***In original carton* (6)**Gevrey-Chambertin Clos Tamisot 2010***In original carton* (12)797 20 bottles *per lot* HK\$10,000-15,000**Domaine Ponsot**

The Ponsot family's involvement in Burgundy began in 1872 with the purchase of the Liébault Domaine in Morey-St.-Denis by William Ponsot. The vineyards acquired included the Clos des Monts-Luisants and a parcel of Clos de la Roche. William died without a son, but his nephew Hippolyte took over the Domaine in 1920 and was one of the pioneers in Burgundy to Domaine-bottle his production, beginning in 1932. Jean-Marie Ponsot, son of Hippolyte, began to work alongside his father in 1942, and from 1961 began to add to the Domaine by working as a sharecropper for parcels in Chambolle-Musigny, Chambertin and Latricières-Chambertin. This expansion continued when his wife Jacqueline Ponsot Livera, inherited parcels in Gevrey Chambertin and Chapelle Chambertin in 1972.

In 1981, Laurent Ponsot began to work alongside his father, and the Domaine was further expanded with agreements in Griotte Chambertin, Chambertin, Clos St Denis and Chambolle Charmes of Domaine des Chezeaux. This expansion continues even nowadays, with recent additions of Charmes Chambertin, Chambertin Clos de Bèze, Clos de Vougeot, Corton and Corton-Charlemagne, and Montrachet among others.

Domaine Ponsot has holdings in some of the finest vineyards of the Côte de Nuits and produce 12 of the 33 Grand Crus of Burgundy and is famous worldwide for its Clos de la Roche that is the flagship of its 20 appellations.

Ponsot is one of the finest Domaines on the Côte d'Or producing wines of great individuality and class. At their best these are opulent, highly concentrated and perfumed wines. This is one of the most interesting properties in Burgundy and a constant source of top wines that combine power and elegance.

彭壽莊

1872年，威廉·彭壽在莫雷聖但尼村購入雷寶莊，自始彭壽家族便開始在勃艮地發展。他們名下的葡萄園包括盧森丘及石頭園。威廉過世時，膝下無兒，但他的外甥依波萊特在1920年接管了酒莊，成為勃艮地的先驅人物之一，自1934年開始在酒莊內裝瓶。依波萊特的兒子讓·瑪麗·彭壽於1942年開始跟隨父親工作，1961年開始加入酒莊，以小佃農身份在香港木樨園、香貝田、拉特西-香貝田葡萄園種植。1972年，他與繼承了熱弗雷-香貝田和教堂-香貝田葡萄園的雅克琳·彭壽·麗薇拉結婚，令酒莊土地增加。

1981年，勞倫·彭壽開始跟隨父親工作，而酒莊繼續拓展土地，通過承租夏祖莊的格利特-香貝田、香貝田、聖丹尼園，以及香波木樨尼村的夏牧園大面。直至今日，土地拓展仍然繼續，新成員包括夏牧-香貝田、梧坎園、哥頓、歌頓查理曼，以及貝日園。

彭壽莊擁有夜丘部分最優質的葡萄園，而且在勃艮地33個特級葡萄園中，彭壽莊就在其中12個釀造葡萄酒，當中石頭園是酒莊所擁有的20個法定產區中的明星，享譽全球。

彭壽是金丘的頂級酒莊之一，其葡萄酒個性獨特，堪稱上品。葡萄酒達至最佳狀態時，豐郁、高度集中而且香氣四溢。它是勃艮地最有趣的酒莊之一，釀造的葡萄酒揉合力量 and 優雅。

自2009年起，彭壽莊每個年份只釀造十瓶6公升裝的老藤石頭園。該葡萄酒從未直接售予顧客。每年只會出售一瓶紐約的慈善拍賣會。其餘的葡萄酒在酒窖繼續陳釀。這五瓶6公升裝彌足珍貴。

Ponsot Assortment 2006**Chambertin**

(1)

Charmes-Chambertin

(1)

Chapelle-Chambertin

(2)

Clos de Vougeot

(2)

Clos de la Roche VV

(2)

Clos Saint Denis TVV

(2)

Griotte-Chambertin

(2)

*In original wooden case*798 12 bottles *per lot* HK\$17,000-24,000



Lots 801-802

DOMAINE PONSOT

Ponsot Assortment 2007					
	Chambertin	(1)			
	Charmes-Chambertin	(2)			
	Chapelle-Chambertin	(2)			
	Clos de Vogeo	(1)			
	Clos de la Roche VV	(2)			
	Clos Saint Denis TVV	(2)			
	Griotte-Chambertin	(2)			
	<i>In original wooden cases</i>				
799	12 bottles		<i>per lot</i>	HK\$17,000-24,000	
800	12 "				
Ponsot Assortment 2010					
	Corton-Charlemagne	(1)			
	Montrachet	(1)			
	Chambertin	(1)			
	Chambertin Clos de Bèze	(1)			
	Charmes-Chambertin Cuvée des Merles	(1)			
	Chapelle-Chambertin	(1)			
	Clos de la Roche VV	(1)			
	Clos Saint Denis TVV	(1)			
	Clos de Vogeo VV	(1)			
	Griotte Chambertin	(1)			
	Corton Cuvée du Bourdon	(1)			
	Corton Bressandes	(1)			
	<i>In original wooden cases</i>				
801	12 bottles		<i>per lot</i>	HK\$24,000-35,000	
802	12 "				
Mixed 2014 Domaine Ponsot Grand Cru White					
	Corton-Charlemagne	(3)			
	Montrachet	(1)			
803	4 bottles		<i>per lot</i>	HK\$17,000-26,000	
Domaine Ponsot, Clos de la Roche Vieilles Vignes 2011					
	<i>Grand Cru, Côte de Nuits</i>				
	<i>In six-bottle original wooden cases</i>				
804	12 bottles		<i>per lot</i>	HK\$28,000-42,000	
Domaine Ponsot, Clos de la Roche Vieilles Vignes 2014					
	<i>Grand Cru, Côte de Nuits</i>				
	<i>In original wooden case</i>				
805	6 bottles		<i>per lot</i>	HK\$15,000-22,000	
Mixed Domaine Ponsot, Clos St. Denis Cuvée Tres VV					
	2009	(1)			
	2010	(1)			
	2011	(3)			
806	5 bottles		<i>per lot</i>	HK\$18,000-28,000	
Domaine Ponsot, Clos St. Denis Cuvée Tres VV 2014					
	<i>Grand Cru, Côte de Nuits</i>				
807	3 bottles		<i>per lot</i>	HK\$11,000-16,000	
Mixed 2014 Domaine Ponsot					
	Chambolle-Musigny Les Charmes	(6)			
	Corton Cuvée du Bourdon	(6)			
	<i>In original wooden cases</i>				
808	12 bottles		<i>per lot</i>	HK\$10,000-15,000	
Mixed Domaine Ponsot					
	Griottes-Chambertin 2010	magnum (1)			
	Morey St. Denis Cuvée des Alouettes 2010	(4)			
	Morey St. Denis Cuvée des Alouettes 2014				
	<i>In original wooden case</i>	(6)			
809	1 magnum and 10 bottles		<i>per lot</i>	HK\$9,000-13,000	
Robert Cheillon, Nuits- Saint-Georges Les Saint-Georges 1999					
	<i>1er Cru, Côte de Nuits</i>				
	<i>In original carton</i>				
810	12 bottles		<i>per lot</i>	HK\$14,000-20,000	
Robert Cheillon, Nuits- Saint-Georges Les Saint-Georges 2005					
	<i>1er Cru, Côte de Nuits</i>				
	<i>In original cartons</i>				
811	12 bottles		<i>per lot</i>	HK\$17,000-24,000	
812	12 "				
Rossignol Trapet, Chambertin 2009					
	<i>Grand Cru, Côte de Nuits</i>				
	<i>In six-bottle original cartons</i>				
813	12 bottles		<i>per lot</i>	HK\$12,000-18,000	
Rossignol Trapet, Chambertin 2010					
	<i>Grand Cru, Côte de Nuits</i>				
	<i>In six-bottle original cartons</i>				
814	12 bottles		<i>per lot</i>	HK\$15,000-22,000	
Sylvain Cathiard, Vosne-Romanée Les Reignots 2003					
	<i>1er Cru, Côte de Nuits</i>				
	<i>In original carton</i>				
815	12 bottles		<i>per lot</i>	HK\$15,000-22,000	
Mixed Château de Beaucastel Châteauneuf-du-Pape					
	Châteauneuf-du-Pape Roussanne VV 2011				
	<i>In six-bottle original wooden cases</i>	(12)			
	Châteauneuf-du-Pape Hommage à Jacques Perrin 2014				
	<i>In banded three-bottle original wooden cases</i>	(6)			
816	18 bottles		<i>per lot</i>	HK\$16,000-24,000	
E. Guigal, Côte-Rôtie La Landonne 1990					
	<i>Rhône</i>				
	<i>Slightly damaged vintage neck labels and labels. Levels 1cm or better</i>				
817	6 bottles		<i>per lot</i>	HK\$24,000-38,000	

E. Guigal, Côte-Rôtie La Landonne 2005
Rhône
In six-bottle original wooden cases
 818 12 bottles *per lot* HK\$30,000-45,000

E. Guigal, Côte-Rôtie La Turquie 1989
Rhône
One sign of old seepage. Two stained vintage neck labels. Levels five 0.5cms, one 3cms
 819 6 bottles *per lot* HK\$22,000-35,000

Mixed 2009 Guigal
Côte-Rôtie La Landonne (3)
Côte-Rôtie La Mouline (3)
Côte-Rôtie La Turquie (3)
In original wooden cases
 820 9 bottles *per lot* HK\$19,000-28,000

Mixed E. Guigal
Hermitage Ex-Voto 2007 (6)
Condrieu la Doriane 2010 (24)
In original wooden cases
 821 30 bottles *per lot* HK\$17,000-26,000

Domaine du Pegau, Châteauneuf-du-Pape Cuvée da Capo 2007
Rhône
In original wooden cases
 822 6 magnums *per lot* HK\$28,000-42,000
 823 6 "

Domaine du Pegau, Châteauneuf-du-Pape Cuvée da Capo 2010
Rhône
In original wooden case
 824 3 magnums *per lot* HK\$12,000-18,000

Mixed Henri Bonneau
Châteauneuf-du-Pape 2007 (6)
Châteauneuf-du-Pape Cuvée Marie Beurrier 2005 (2)
Châteauneuf-du-Pape Cuvée Marie Beurrier 2008 (4)
Les Rouliers NV (6)
 825 18 bottles *per lot* HK\$10,000-16,000

Domaine Jamet, Côte-Rôtie 2001
Rhône
In original cartons
 826 24 bottles *per lot* HK\$28,000-42,000

Mixed Rene Rostaing
Côte-Rôtie Côte Blonde 2004 (3)
Côte-Rôtie Côte Blonde 2005 (4)
Côte-Rôtie La Landonne 2005 (4)
 827 11 bottles *per lot* HK\$7,000-10,000

Roger Sabon, Châteauneuf-du-Pape Cuvée Prestige 2000
Rhône
In original carton
 828 12 bottles *per lot* HK\$3,200-4,800

Mixed Azelia
Barolo San Rocco 1997 (6)
Barolo Bricco Fiasco 2004 (6)
 829 12 bottles *per lot* HK\$6,000-8,500

Mixed Bruno Giacosa
Barbaresco Asili 1997
Slightly stained and two slightly damaged labels (6)
Barolo Rocche del Falletto 2009
In original wooden case (6)
 830 12 bottles *per lot* HK\$9,500-15,000

Gaja, Conteisa 2007
Piedmont
In six-bottle original wooden cases
 831 24 bottles *per lot* HK\$15,000-22,000

Giacomo Conterno, Barolo Cascina Francia 2001
Piedmont
In twelve-bottle original carton
 832 6 bottles *per lot* HK\$7,000-11,000

Giacomo Conterno, Barolo Monfortino 2002
Piedmont
 833 7 bottles *per lot* HK\$26,000-40,000

Mixed Pio Cesare
Barolo 2004
In three-bottle original wooden cases (12)
Barbaresco Il Bricco 2007
In six-bottle original wooden cases (12)
 834 24 bottles *per lot* HK\$10,000-15,000

Mixed 2005 & 2007 Pio Cesare Barolo Ornato 2005 magnums (5)
Three in individual original wooden cases. Two in three-bottle original wooden cases
2007
In six-bottle original wooden cases (12)
 835 5 magnums and 12 bottles *per lot* HK\$12,000-19,000



2007

2007

Châteauneuf-du-Pape
Contrôle

DOMAINE
PEGAU



Châteauneuf-du-Pape

APPELLATION CHATEAUNEUF-DU-PAPE CONTRÔLÉE

Lots 822 & 823
Mise en Bouteille au Domaine
Paul FERAUD et Fille, Propriétaires Récoltants
à CHATEAUNEUF-DU-PAPE - Vse - FRANCE

alc. 13.5% by vol.

PRODUCT OF FRANCE

1500 ml

Antinori, Guado al Tasso 2009

Tuscany

In six-bottle original wooden cases

836 12 bottles per lot HK\$6,500-9,500

Mixed Antinori Tignanello & Solaia**Tignanello 2012**

In original carton

(6)

Solaia 2013

In original wooden case

(6)

837 12 bottles per lot HK\$8,500-13,000

Casanova di Neri, Brunello di Montalcino Tenuta Nuova 2006

Tuscany

In original cartons

838 24 bottles per lot HK\$16,000-24,000

Case Basse di Gianfranco Soldera 2009

Tuscany

839 12 bottles per lot HK\$20,000-30,000



Lot 839

Sassicaia 2006

Tuscany

In six-bottle original wooden cases

840 12 bottles per lot HK\$13,000-20,000

Tenuta di Trinoro, Palazzi 1997

Tuscany

In twelve-bottle original wooden case without lid

841 6 bottles per lot HK\$4,200-6,500

Tua Rita, Giusto di Notri 2007

Tuscany

In six-bottle original cartons

842 24 bottles per lot HK\$9,000-14,000

Tua Rita, Redigaffi 2006

Tuscany

In six-bottle original cartons

843 12 bottles per lot HK\$12,000-18,000

Tua Rita, Redigaffi 2010

Tuscany

Six in six-bottle original wooden case. Three in three-bottle original wooden case

844 9 bottles per lot HK\$9,000-14,000

Quintarelli, Recioto della Valpolicella 1997

Veneto

In six-bottle original cartons

845 12 bottles per lot HK\$24,000-38,000

Quintarelli, Amarone della Valpolicella 1998

Veneto

In six-bottle original cartons

846 12 bottles per lot HK\$24,000-38,000

Quintarelli, Amarone della Valpolicella 2003

Veneto

In original carton

847 6 bottles per lot HK\$13,000-19,000

Artadi Vina El Pison 2005

Rioja

In original wooden case

848 6 bottles per lot HK\$7,000-10,000

Artadi Vina El Pison 2013

Rioja

In six-bottle original wooden cases

849 12 bottles per lot HK\$11,000-17,000

Artadi Vina El Pison 2014

Rioja

In six-bottle original wooden cases

850 23 bottles per lot HK\$28,000-42,000

La Rioja Alta Gran Reserva 890 2001
 Rioja
In six-bottle original wooden cases
 851 24 bottles *per lot* HK\$16,000-24,000

La Rioja Alta Gran Reserva 904 1997
 Rioja
In three-bottle original wooden cases
 852 21 bottles *per lot* HK\$8,000-12,000

Mixed La Rioja Alta Gran Reserva 904
1982
In three-bottle original wooden case. Slightly stained labels. Levels one base of neck, three top shoulder, five upper shoulder (9)
1985
In original wooden case. Levels base of neck (3)
1994
In original wooden case. Levels two into neck, one base of neck (3)
 853 15 bottles *per lot* HK\$9,000-14,000

Flor de Pingus 2004
 Ribera del Duero
In original cartons
 854 24 bottles *per lot* HK\$20,000-32,000

Flor de Pingus 2006
 Ribera del Duero
In original carton
 855 12 bottles *per lot* HK\$8,000-12,000

Mixed Quinta do Noval Nacional
1996 (3)
1999 (3)
2004 (2)
In individual original cartons
 856 8 bottles *per lot* HK\$20,000-32,000

Mixed F.X. Pichler
Gruner Veltliner Smaragd Loibner Berg 2008
In original carton (12)
Gruner Veltliner Smaragd M 2010 (3)
Durnsteiner Kellerberg Riesling Smaragd 2007 (6)
Durnsteiner Kellerberg Riesling Smaragd 2008
In original carton (12)
Loibner Steinertal Riesling Smaragd 2007 (6)
 857 39 bottles *per lot* HK\$9,000-14,000

Colgin IX Estate Syrah 2006
 Napa Valley
In original carton
 858 12 bottles *per lot* HK\$11,000-16,000



Lot 855

Dominus Estate

Christian Moueix fell in love with the Napa Valley and its wines in the late 1960's, while attending the University of California at Davis. In 1981, he discovered the Napanook Vineyard, a site west of Yountville that had been the source of fruit for some of the finest Napa Valley wines of the 1940's and 1950's. The vineyard's history can be traced back to Napa Valley's beginnings, when George Yount planted some of the region's first vines there in 1838. Today, the historic vineyard produces two wines composed primarily of Cabernet Sauvignon: Dominus Estate and Napanook, a second wine made from the fruit of younger vines.

Christian Moueix chose the name 'Dominus' ('lord of the estate' in Latin) to underscore his longstanding commitment to the land. Rooted in values of quality, stewardship, tradition and innovation, the Dominus Estate team shares a vision of producing distinctive wines that are expressive of this singular terroir.

The vineyard is entirely dry-farmed, allowing the vines to draw deeply on the land's unique geology. The viticulture and winemaking are undertaken meticulously, with the objective of producing wines that are pure, balanced, and complex. Minimal intervention and restraint throughout the process of grape berry selection, fermentation and ageing preserve the character of the fruit. The resulting wines, with a tremendous potential for aging, convey the very personality of this historic vineyard.

多明納斯酒莊

克利斯蒂安·莫埃爾於1960年代在加州大學戴維斯分校讀書，從此愛上納帕穀及當地的葡萄酒。1981年，他在揚特維爾以西發現納帕谷克葡萄園，1940至50年代納帕穀頂級佳釀使用的葡萄皆出於此處。葡萄園歷史可追溯至1838年，喬治·楊特在當地種植首批葡萄。這座歷史悠久的葡萄園現時出產兩種主要以赤霞珠釀造的葡萄酒，包括多明納斯及以樹齡較淺的葡萄樹果實釀製的納帕谷克。

克利斯蒂安·莫埃爾將酒莊命名為「多明納斯」（在拉丁文中，意指「莊主」），彰顯他對酒莊的長遠承擔。多明納斯酒莊重視品質、管理、傳統與創新，團隊上下一心，銳意釀造出體現獨特風土的獨特珍釀。

葡萄園以旱地農耕方式種植，令葡萄樹充分吸收土地獨特的地質特性。種植葡萄及釀酒過程一絲不苟，致力釀造出醇香平衡、口感複雜的佳釀。酒莊盡量不干預及限制選擇葡萄、發酵及陳年的過程，以求保留葡萄原有的特質。成品皆非常適合陳年，展現這座古老莊園的獨特韻味。

	Dominus 2010		
	<i>Napa Valley</i>		
	<i>In six-bottle original wooden cases</i>		
859	12 bottles	<i>per lot</i>	HK\$22,000-32,000
	Dominus 2012		
	<i>Napa Valley</i>		
	<i>In six-bottle original wooden cases</i>		
860	12 bottles	<i>per lot</i>	HK\$14,000-22,000
861	12 "		
862	12 "		
	Dominus 2013		
	<i>Napa Valley</i>		
	<i>In six-bottle original wooden cases</i>		
863	12 bottles	<i>per lot</i>	HK\$24,000-35,000
	Dominus Napanook 2009		
	<i>Napa Valley</i>		
	<i>In original wooden case</i>		
864	12 bottles	<i>per lot</i>	HK\$3,800-5,500
	Harlan Estate 2012		
	<i>Napa Valley</i>		
	<i>In original wooden case</i>		
865	6 bottles	<i>per lot</i>	HK\$28,000-42,000
	Harlan The Maiden 2012		
	<i>Napa Valley</i>		
	<i>In original wooden case</i>		
866	6 bottles	<i>per lot</i>	HK\$8,500-13,000

Sine Qua Non, Next Of kyn Assortment 2008

2008 magnum (1)
2008 (3)

In original wooden case
867 1 magnum and 3 bottles *per lot* HK\$15,000-24,000

Mixed Sine Que Non

Body And Soul 2007 (1)

Grenache Upside Down 2009 (5)
868 6 bottles *per lot* HK\$8,500-12,000

Mixed 2001 Clarendon Hills

Hickinbotham Syrah (6)

Piggott Range Syrah (6)

Romas Grenache Old Vines (6)
869 18 bottles *per lot* HK\$6,500-9,500

Henschke, Mount Edelstone Shiraz 2005

Eden Valley
870 12 bottles *per lot* HK\$5,500-8,500

End of Sale
拍賣結束



Lots 860-862

Index by Vintage

WINE	Lot No.	WINE	Lot No.
CHAMPAGNE		2010	
1996		Carruades de Lafite-Rothschild	497
Jacquesson, Sillery	483	Château Pichon-Longueville, Baron	505
2002		2011	
Krug	484	Château Lafite-Rothschild	492-493
NV		Château Mouton-Rothschild	502
Jacques Selosse, Brut Initial	478	Le Pin	523
Jacques Selosse, Sous le Mont	479	2012	
Jacques Selosse, Substance	480	Château Lafite-Rothschild	494-496
Jacques Selosse, Rosé	481	Château Mouton-Rothschild	503
Jacques Selosse, Rosé	482	Château Haut-Brion	513-514
Jacquesson, Sillery	483	Le Pin	524
Krug Rosé	485	Château Ausone	529
MIXED		2014	
Mixed Henri Giraud	477	Château La Mission-Haut-Brion	516
Mixed 2000 Philipponnat & Veuve Clicquot Rosé	486	MIXED	
Mixed Champagne	487	Mixed Château Batailley & Château Pichon Lalande	507
BORDEAUX WHITE		Mixed 2011 Château Pontet-Canet & Château Ducru-Beaucaillou	509
1999		Mixed 2006 & 2010 Château Gruaud-Larose	510
Château d'Yquem	536	Mixed Château Kirwan & Château Giscours	517
2009		Mixed Château Chasse Spleen & Château Haut Bailly	518
Liquid Gold Assortment	538	Mixed 2011 Château Clinet & Vieux-Château-Certan	520
MIXED		Mixed Château Canon-La-Gaffelière & Château Quinault L'Enclos	535
Mixed 2003 & 2005 Château Rieussec	537	BURGUNDY WHITE	
BORDEAUX RED		1964	
1982		Maison Leroy, Meursault Genevrières	763
Château Calon-Ségur	488	1992	
Château Pichon-Longueville, Lalande	506	Maison Leroy, Meursault Genevrières	764
Vieux-Château-Certan	521	1996	
1983		Labouré-Roi, Montrachet	550
Château Palmer	511	1999	
1986		Domaine Leflaive, Puligny-Montrachet Les Pucelles	558
Château Latour	498	2001	
1989		Domaine Leflaive, Chevalier-Montrachet	552
Château Palmer	512	2004	
1990		Domaine des Comtes Lafon, Meursault-Perrières	541
Château Lafite-Rothschild	491	2005	
Château Latour	499	Domaine Leflaive, Bâtard-Montrachet	551
1995		Domaine Leflaive, Puligny-Montrachet Clavoillon	556
Château Cos d'Estournel	489	2006	
1998		Vincent Girardin, Chevalier-Montrachet	567
Château Cheval-Blanc	530	2007	
2000		Henri Boillot, Criots Bâtard-Montrachet	549
Château Léoville-Poyferré	508	2008	
Château L'Eglise Clinet	525	Domaine de la Romanée-Conti, Montrachet	643
Château Valandraud	534	Joseph Drouhin, Chablis Les Clos	739
2001		2009	
Château Cheval-Blanc	531	Guy Amiot, Montrachet	548
2005		Domaine Leflaive, Bienvenues-Bâtard-Montrachet	554
Château Pichon-Longueville, Baron	504	Marc Colin, Montrachet	563
Château Le Tertre-Roteboeuf	532-533	Vincent Girardin, Bienvenues-Bâtard-Montrachet	568
2006		2011	
Château Mouton-Rothschild	500-501	Joseph Drouhin, Montrachet Marquis de Laguiche	740-741
Château Ausone	527	2012	
2007		Joseph Drouhin, Montrachet Marquis de Laguiche	742
Château Ausone	528	2013	
2008		Domaine Ramonet Assortment	565
Château La Violette	522	Joseph Drouhin, Montrachet Marquis de Laguiche	743-744
2009		2014	
Château Cos d'Estournel	490	Joseph Drouhin, Montrachet Marquis de Laguiche	745
Château La Mission-Haut-Brion	515	2015	
Château Clinet	519	François Mikulski, Meursault Genevrières	547
Château Trotanoy	526	MIXED	
		Mixed 2011-2013 Coche Dury, Meursault	539
		Mixed 2011-2013 Domaine des Comtes Lafon, Montrachet	540

Index by Vintage

WINE	Lot No.	WINE	Lot No.
Mixed 2008 & 2009 Domaine des Comtes Lafon	542	Louis Remy, Latricières-Chambertin	781
Domaine des Comtes Lafon Assortment 2011 & 2012	543	Patrice Rion, Chambolle-Musigny Les Amoureuses	792
Mixed Domaine Leflaive Grand Crus	544	Ponsot Assortment	798
Mixed 2010 Domaine des Héritiers du Comte Lafon	545	2007	
Mixed François Mikulski	546	Jacques Prieur, Musigny	732
Mixed 2005 & 2009 Domaine Leflaive, Chevalier-Montrachet	553	Joseph Drouhin, Chambertin Clos de Bèze	752-723
Mixed Domaine Leflaive Grand Crus	555	Louis Jadot, Chambertin Clos de Bèze	774
Mixed Domaine Leflaive, Puligny Montrachet 1er Crus	557	Louis Jadot, Musigny	775
Mixed Domaine Leflaive, Puligny-Montrachet Les Pucelles	559	Ponsot Assortment	799-800
Mixed Domaine Leflaive, Puligny-Montrachet	560	2008	
Mixed Domaine Leflaive, Burgogne Blanc	561	Domaine de la Romanée-Conti, Romanée-Conti	644
Mixed 2010 Domaine Leflaive	562	Domaine de la Romanée-Conti,	
Mixed 1994 Domaine Ramonet	564	Vosne-Romanée Cuvée Duvault-Blochot	668
Mixed 2014 Jean Claude Ramonet	566	Jacques Prieur, Musigny	733
Mixed 2006 Vincent Girardin	569	Jean-Louis Trapet, Chambertin	736
Mixed William Fèvre 2008	570	Joseph Drouhin, Chambolle-Musigny Les Amoureuses	755
		Domaine du Comte Liger-Belair, Vosne Romanée	773
		Louis Jadot, Musigny	776
		Lucien Le Moine, Clos St. Denis	782
		2009	
		Armand Rousseau, Chambertin Clos de Bèze	584
		Domaine Bachelet, Gevrey-Chambertin Vieilles Vignes	605
		Cecile Tremblay, Chambolle-Musigny Les Cabottes	608
		Cecile Tremblay, Vosne-Romanée Les Beaumonts	611
		Cecile Tremblay, Vosne-Romanée Les Rouges du Dessus	612
		Comte Georges de Vogüé, Musigny Vieilles Vignes	615
		Comte Georges de Vogüé, Bonnes Mares	622
		Domaine de la Vougeraie, Bonnes Mares	636
		Domaine de la Vougeraie, Musigny	637
		Domaine de la Romanée-Conti, Richebourg	651
		Domaine de la Romanée-Conti, Romanée-Saint-Vivant	655
		Domaine de la Romanée-Conti,	
		Vosne-Romanée Cuvée Duvault-Blochot	669
		Domaine d'Eugenie, Clos de Vougeot	670
		Domaine Duroche, Chambertin Clos de Bèze	673
		Emmanuel Rouget, Vosne-Romanée Les Beaumonts	680
		François Lamarche, Echézeaux	699
		Georges Roumier, Morey-Saint-Denis Clos de la Bussière	711
		Georges Roumier, Chambolle-Musigny	713
		J.F. Mugnier, Chambolle-Musigny	727
		Jacques Prieur, Musigny	734
		Joseph Drouhin, Chambolle-Musigny Les Amoureuses	756
		Joseph Roty, Charmes Chambertin Cuvée Vieilles Vignes	762
		Patrice Rion, Chambolle-Musigny Les Amoureuses	793
		Rossignol Trapet, Chambertin	813
		2010	
		Alain Burguet, Chambertin Clos de Bèze	571
		Armand Rousseau, Chambertin	579
		Armand Rousseau, Ruchottes-Chambertin Clos des Ruchottes	595
		Armand Rousseau, Gevrey-Chambertin Clos Saint Jacques	599
		Domaine Arnoux-Lachaux, Romanée-Saint-Vivant	604
		Comte Georges de Vogüé, Musigny Vieilles Vignes	616
		Domaine de la Romanée-Conti, Echézeaux	660
		Domaine Faiveley, Chambertin Clos de Bèze	683
		François Lamarche, La Grande Rue	700
		Lucien Le Moine, Clos St. Denis	783
		Pierre Damoy, Chambertin	795
		Ponsot Assortment	801-802
		Rossignol Trapet, Chambertin	814
		2011	
		Armand Rousseau, Chambertin	580
		Armand Rousseau, Chambertin Clos de Bèze	585
		Cecile Tremblay, Chambolle-Musigny Les Cabottes	609
		Comte Georges de Vogüé, Musigny Vieilles Vignes	617
		Domaine de la Vougeraie, Musigny	638
		Domaine de la Romanée-Conti, La Tâche	647
BURGUNDY RED			
1984			
Comte Georges de Vogüé, Chambolle-Musigny	629		
1985			
Maison Leroy, Gevrey Chambertin 1er Cru	765		
1997			
Emmanuel Rouget, Echézeaux	678		
Emmanuel Rouget, Vosne-Romanée Cros Parantoux	679		
1999			
Anne-Françoise Gros, Richebourg	573		
Domaine de la Romanée-Conti, Echézeaux	659		
Robert Chevillon, Nuits- Saint-Georges Les Saint-Georges	810		
2002			
Albert Bichot, Chambertin	572		
Maison Roche de Bellen, Clos de la Roche Collection Bellenum	606		
Domaine de la Romanée-Conti, Grands-Echézeaux	664		
Joseph Faiveley, Chambertin Clos de Bèze	682		
Jean Grivot, Vosne-Romanée Les Beaumonts	735		
Pierre Damoy, Chambertin Clos de Bèze	796		
2003			
Domaine de la Romanée-Conti, Richebourg	650		
Sylvain Cathiard, Vosne-Romanée Les Reignots	815		
2004			
Domaine Fourrier, Gevrey-Chambertin Champeaux	697		
Joseph Drouhin, Musigny	746		
2005			
Armand Rousseau, Chambertin	578		
Armand Rousseau, Charmes-Chambertin	589		
Armand Rousseau, Clos de la Roche	592		
Armand Rousseau, Ruchottes-Chambertin Clos des Ruchottes	594		
Armand Rousseau, Gevrey-Chambertin Lavaux Saint-Jacques	603		
Château de Puligny-Montrachet, Pommard Pézerolles	613		
Comte Georges de Vogüé, Bonnes Mares	621		
Comte Georges de Vogüé, Chambolle-Musigny Les Amoureuses	624		
Comte Georges de Vogüé, Chambolle-Musigny 1er Cru	627		
Comte Georges de Vogüé, Chambolle-Musigny	630		
Follin Arbelet, Romanée-Saint-Vivant	693-694		
Georges Jayet, Nuits-Saint-Georges	702		
Domaine de Montille, Corton Pougets	719		
J.F. Mugnier, Bonnes Mares	724		
Joseph Drouhin, Chablis Bougros	738		
Domaine du Comte Liger-Belair, Vosne Romanée Aux Reignots	770		
Louis Remy, Chambertin	779		
Louis Remy, Latricières-Chambertin	780		
Mommessin, Clos de Tart	787		
Robert Chevillon, Nuits- Saint-Georges Les Saint-Georges	811-812		
2006			
Comte Georges de Vogüé, Chambolle-Musigny Les Amoureuses	625		
Joseph Drouhin, Chambertin Clos de Bèze	751		

Index by Vintage

WINE	Lot No.	WINE	Lot No.
Domaine de la Romanée-Conti, Richebourg	652	Mixed Domaine Anne Gros	576
Domaine de la Romanée-Conti, Romanée-Saint-Vivant	656	Mixed 2013 Domaine Anne Gros	577
Domaine de la Romanée-Conti, Echézeaux	661	Mixed 2013 & 2014 Armand Rousseau, Charmes-Chambertin	590
Domaine de la Romanée-Conti, Grands-Echézeaux	665	Mixed Armand Rousseau Clos de la Roche & Charmes-Chambertin	591
Domaine Faiveley, Chambertin Clos de Bèze Ouvrées Rodin	685	Mixed 2009 & 2011 Armand Rousseau Clos de la Roche	593
Domaine Faiveley Musigny	690	Mixed 2011 & 2012 A. Rousseau,	
Jean-Pierre Mathieu, Charmes-Chambertin Aux Mazoyeres	737	Ruchottes-Chambertin Clos des Ruchottes	596
Joseph Drouhin, Musigny	748-749	Mixed A. Rousseau Gevrey-Chambertin Clos Saint Jacques	600
Joseph Drouhin, Chambertin Clos de Bèze	754	Mixed 2011 & 2012 Cecile Tremblay Chapelle-Chambertin	607
Domaine Ponsot, Clos de la Roche Vieilles Vignes	804	Mixed 2012 & 2013 Cecile Tremblay,	
2012		Chambolle-Musigny Les Cabottes	610
Armand Rousseau, Chambertin	581	Mixed 2005 Claude Dugat	614
Armand Rousseau, Chambertin Clos de Bèze	586	Mixed 2012 Comte Georges de Vogüé	620
Comte Georges de Vogüé, Musigny Vieilles Vignes	618	Mixed 2011 & 2014 Comte de Vogue Chambolle Musigny 1er Cru	628
Domaine de la Romanée-Conti, Romanée-Conti	645	Mixed Comte Georges de Vogüé, Chambolle-Musigny	631
Domaine de la Romanée-Conti, La Tâche	648	Mixed Comte Georges de Vogüé 2013	632-634
Domaine de la Romanée-Conti, Richebourg	653	Mixed Comte Georges de Vogüé 2014	635
Domaine de la Romanée-Conti, Romanée-Saint-Vivant	657	Mixed 2012 & 2013 Domaine de la Vougeraie Musigny	639
Domaine de la Romanée-Conti, Echézeaux	662	Mixed 2013 Domaine de l'Arlot	640-641
Domaine de la Romanée-Conti, Grands-Echézeaux	666	DRC Assortment 2008	642
Drouhin Laroze, Chambertin Clos de Bèze	674	Mixed 2009 & 2010 Domaine d'Eugenie, Grands-Echézeaux	671
Follin Arbelet, Romanée-Saint-Vivant	695	Mixed Domaine d'Eugenie	672
Georges Roumier, Musigny	706	Mixed Domaine Drouhin-Laroze & Joseph Drouhin 2010	676
Georges Roumier, Chambolle-Musigny Les Amoureuses	709	Mixed 2009 Domaine Dujac	677
Domaine Henri Gouges, Nuits St. Georges Les St. Georges	717	Mixed Faiveley White	681
J.F. Mugnier, Musigny	723	Mixed Domaine Faiveley Chambertin Clos de Bèze Ouvrées Rodin	687
Joseph Drouhin, Musigny	750	Mixed 1999 & 2013 Faiveley, Mazis Chambertin	688
2013		Mixed 2010 & 2011 Domaine Faiveley, Mazis Chambertin	689
Armand Rousseau, Chambertin	582	Mixed 2014 Domaine Faiveley	691-692
Armand Rousseau, Chambertin Clos de Bèze	587	Mixed Domaine Fourrier	698
Armand Rousseau, Ruchottes-Chambertin Clos des Ruchottes	597	Mixed François Lamarche & Chantal Remy	701
Armand Rousseau, Gevrey-Chambertin Clos Saint Jacques	601	Mixed 2012 & 2013 Georges Lignier Bonnes Mares	703
Domaine de la Romanée-Conti, Romanée-Conti	646	Mixed 2012 & 2013 Georges Lignier Clos de la Roche	704
Domaine de la Romanée-Conti, La Tâche	649	Mixed Georges Lignier	705
Domaine de la Romanée-Conti, Richebourg	654	Mixed G. Roumier Bonnes Mares	708
Domaine de la Romanée-Conti, Romanée-Saint-Vivant	658	Mixed Georges Roumier	712
Domaine de la Romanée-Conti, Echézeaux	663	Mixed 2010-2012 Georges Roumier Chambolle Musigny	714
Domaine de la Romanée-Conti, Grands-Echézeaux	667	Mixed Gros Frère et Sœur, Clos Vougeot Musigni	715
Drouhin Laroze, Chambertin Clos de Bèze	675	Mixed 2009 & 2011 Gros Frère et Sœur, Grands Echézeaux	716
Domaine Faiveley, Chambertin Clos de Bèze Ouvrées Rodin	686	Mixed Domaine de Montille	720
Follin Arbelet, Romanée-Saint-Vivant	696	Mixed 2005 Domaine de Montille	721
Georges Roumier, Musigny	707	Mixed 2009 & 2010 J.F. Mugnier Musigny	722
Georges Roumier, Chambolle-Musigny Les Amoureuses	710	Mixed 2009 & 2010 J.F. Mugnier,	
Domaine Henri Gouges, Nuits St. Georges Les St. Georges	718	Chambolle-Musigny Les Amoureuses	725
J.F. Mugnier, Chambolle-Musigny Les Amoureuses	726	Mixed 2009 & 2010 J.F. Mugnier Chambolle-Musigny	728
Domaine du Comte Liger-Belair, La Romanée	766	Mixed 2011-2013 J.F. Mugnier Chambolle-Musigny	729
Domaine du Comte Liger-Belair, Nuits St. Georges Aux Lavières	768	Mixed J.F. Mugnier Nuits St. Georges Clos de la Maréchale red & white	730
Domaine du Comte Liger-Belair, Vosne Romanée Clos du Château	771	Mixed 2010 J.F. Mugnier	731
2014		Mixed 2009 Joseph Drouhin Musigny	747
Armand Rousseau, Chambertin	583	Mixed 2009 & 2011 Joseph Drouhin Grand Crus Red	757
Armand Rousseau, Chambertin Clos de Bèze	588	Mixed Joseph Drouhin Echézeaux & Grands Echézeaux	758
Armand Rousseau, Ruchottes-Chambertin Clos des Ruchottes	598	Mixed Joseph Drouhin Chambertin Clos de Bèze &	
Armand Rousseau, Gevrey-Chambertin Clos Saint Jacques	602	Chambolle-Musigny Les Amoureuses	759
Mixed 2014 Comte Georges de Vogüé, Musigny Vieilles Vignes	619	Mixed Joseph Drouhin Grand Crus	760
Comte Georges de Vogüé, Bonnes Mares	623	Mixed Joseph Drouhin	761
Mixed 2014 de Vogüé, Bonnes Mares & Chambolle-Musigny Les		Mixed 2009 & 2010 Louis Jadot, Grands-Echézeaux	777
Amoureuses	626	Mixed Louis Jadot	778
Domaine Faiveley, Chambertin Clos de Bèze	684	Mixed Lucien Le Moine	784
Domaine du Comte Liger-Belair, La Romanée	767	Mixed Marius Delarche	785
Domaine du Comte Liger-Belair, Nuits St. Georges Aux Lavières	769	Mixed 2005 & 2013 Marquis d'Angerville Volnay Champans	786
Domaine du Comte Liger-Belair, Vosne Romanée Clos du Château	772	Mixed Méo-Camuzet & Nicolas Potel	788
Domaine Ponsot, Clos de la Roche Vieilles Vignes	805	Mixed 2012 Olivier Bernstein Grand Crus	789
Domaine Ponsot, Clos St Denis Cuvée Tres VV	807	Mixed Olivier Bernstein	790
MIXED		Mixed Olivier Bernstein Gevrey-Chambertin	791
Mixed 2012 Anne-Françoise Gros	574	Mixed 1999 & 2009 Pierre Damoy Chambertin	794
Mixed Domaine Anne Gros, Richebourg	575	Mixed Pierre Damoy	797

Index by Vintage

WINE	Lot No.	WINE	Lot No.
Mixed 2014 Domaine Ponsot Grand Cru White	803	2005	
Mixed Domaine Ponsot, Clos St Denis Cuvée Tres VV	806	Artadi Vina El Pison	848
Mixed 2014 Domaine Ponsot	808	2006	
Mixed Domaine Ponsot	809	Flor de Pingus	855
RHÔNE		2013	
1989		Artadi Vina El Pison	849
E. Guigal, Côte-Rôtie La Turque	819	2014	
1990		Artadi Vina El Pison	850
E. Guigal, Côte-Rôtie La Landonne	817	MIXED	
2000		Mixed La Rioja Alta Gran Reserva 904	853
Roger Sabon, Châteauneuf-du-Pape Cuvée Prestige	828	PORTUGAL	
2001		MIXED	
Domaine Jamet, Côte-Rôtie	826	Mixed Quinta do Noval Nacional	856
2005		AUSTRIA	
E. Guigal, Côte-Rôtie La Landonne	818	MIXED	
2007		Mixed F.X. Pichler	857
Domaine du Pegau, Châteauneuf-du-Pape Cuvée da Capo	822-823	USA	
2010		2006	
Domaine du Pegau, Châteauneuf-du-Pape Cuvée da Capo	824	Colgin IX Estate Syrah	858
MIXED		2008	
Mixed Château de Beaucastel Châteauneuf-du-Pape	816	Sine Qua Non, Next Of kyn Assortment	867
Mixed 2009 Guigal	820	2009	
Mixed E. Guigal	821	Dominus Napanook	864
Mixed Henri Bonneau	825	2010	
Mixed Rene Rostaing	827	Dominus	859
ITALY		2012	
1997		Harlan Estate	865
Tenuta di Trinoro, Palazzi	841	Harlan The Maiden	866
Quintarelli, Recioto della Valpolicella	845	Dominus	860-862
1998		2013	
Quintarelli, Amarone della Valpolicella	846	Dominus	863
2001		MIXED	
Giacomo Conterno, Barolo Cascina Francia	832	Mixed Sine Que Non	868
2002		AUSTRALIA	
Giacomo Conterno, Barolo Monfortino	833	2005	
2003		Henschke, Mount Edelstone Shiraz	870
Quintarelli, Amarone della Valpolicella	847	MIXED	
2006		Mixed 2001 Clarendon Hills	869
Casanova di Neri, Brunello di Montalcino Tenuta Nuova	838		
Sassicaia	840		
Tua Rita, Redigaffi	843		
2007			
Gaja, Conteisa	831		
Tua Rita, Giusto di Notri	842		
2009			
Antinori, Guado al Tasso	836		
Case Basse di Gianfranco Soldera	839		
2010			
Tua Rita, Redigaffi	844		
MIXED			
Mixed Azelia	829		
Mixed Bruno Giacosa	830		
Mixed Pio Cesare	834		
Mixed 2005 & 2007 Pio Cesare Barolo Ornato	835		
Mixed Antinori Tignanello & Solaia	837		
SPAIN			
1997			
La Rioja Alta Gran Reserva 904	852		
2001			
La Rioja Alta Gran Reserva 890	851		
2004			
Flor de Pingus	854		



**Immerse yourself
in the art world,
*wherever you are.***

This October, Christie's Education will launch online learning programmes in English, Mandarin and Arabic.

Learn the way you want to.

Find out more

christies.com/christies-education-online

**讓你無論身在何處，
都能全情投入藝術世界。**

佳士得美術學院將於十月推出網上課程，
並將以英語、普通話和阿拉伯語授課，
讓你自選理想進修方式。

詳情

christies.com/christies-education-online

CHRISTIE'S
EDUCATION 佳士得美術學院

DEGREE PROGRAMMES • CONTINUING EDUCATION • ONLINE COURSES

學位課程 • 持續進修課程 • 網上課程



Short Courses in Hong Kong

Autumn 2017

Art, Law and Ethics

4-6 September

Crossroads: Chinese Contemporary Art

Thursday Evenings, 12 October-23 November

**Fundamentals of Western Art:
European Art before World War II**

23-24 November | Mandarin

25-26 November | English

佳士得美術學院 香港短期課程

2017年秋季

藝術、法律與倫理

9月4 - 6日 | 英語

十字路口的中國當代藝術

10月12日 - 11月23日 | 周四晚間 | 英語

西方藝術史基礎：二戰前的歐洲藝術

11月23 - 24日 | 普通話

11月25 - 26日 | 英語

CHRISTIE'S

EDUCATION 佳士得美術學院

CONDITIONS OF SALE • BUYING AT CHRISTIE'S

CONDITIONS OF SALE

These Conditions of Sale and the Important Notices and Explanation of Cataloguing Practice set out the terms on which we offer the **lots** listed in this catalogue for sale. By registering to bid and/or by bidding at auction you agree to these terms, so you should read them carefully before doing so. You will find a glossary at the end explaining the meaning of the words and expressions coloured in **bold**.

Unless we own a **lot** (▲ symbol), Christie's acts as agent for the seller.

A BEFORE THE SALE

1 DESCRIPTION OF LOTS

(a) Certain words used in the catalogue description have special meanings. You can find details of these on the page headed "Important Notices and Explanation of Cataloguing Practice" which forms part of these terms. You can find a key to the Symbols found next to certain catalogue entries under the section of the catalogue called "Symbols Used in This Catalogue".

(b) Our description of any **lot** in the catalogue, any **condition** report and any other statement made by us (whether orally or in writing) about any **lot**, including about its nature or **condition**, artist, period, materials, approximate dimensions or **provenance** are our opinion and not to be relied upon as a statement of fact. We do not carry out in-depth research of the sort carried out by professional historians and scholars. All dimensions and weights are approximate only.

2 OUR RESPONSIBILITY FOR OUR DESCRIPTION OF LOTS

We do not provide any guarantee in relation to the nature of a **lot** apart from our **authenticity warranty** contained in paragraph E2 and to the extent provided in paragraph I below.

3 CONDITION

(a) The **condition** of **lots** sold in our auctions can vary widely due to factors such as age, previous damage, restoration, repair and wear and tear. Their nature means that they will rarely be in perfect **condition**. **Lots** are sold "as is" in the **condition** they are in at the time of the sale, without any representation or warranty or assumption of liability of any kind as to **condition** by Christie's or by the seller.

(b) Any reference to **condition** in a catalogue entry or in a **condition** report will not amount to a full description of **condition**, and images may not show a **lot** clearly. Colours and shades may look different in print or on screen to how they look on physical inspection. **Condition** reports may be available to help you evaluate the **condition** of a **lot**. **Condition** reports are provided free of charge as a convenience to our buyers and are for guidance only. They offer our opinion but they may not refer to all faults, inherent defects, restoration, alteration or adaptation because our staff are not professional restorers or conservators. For that reason they are not an alternative to examining a **lot** in person or taking your own professional advice. It is your responsibility to ensure that you have requested, received and considered any **condition** report.

4 VIEWING LOTS PRE-AUCTION

(a) If you are planning to bid on a **lot**, you should inspect it personally or through a knowledgeable representative before you make a bid to make sure that you accept the description and its **condition**. We recommend you get

your own advice from a restorer or other professional adviser.

(b) Pre-auction viewings are open to the public free of charge. Our specialists may be available to answer questions at pre-auction viewings or by appointment.

5 ESTIMATES

Estimates are based on the **condition**, rarity, quality and **provenance** of the **lots** and on prices recently paid at auction for similar property. **Estimates** can change. Neither you, nor anyone else, may rely on any **estimates** as a prediction or guarantee of the actual selling price of a **lot** or its value for any other purpose. **Estimates** do not include the **buyer's premium** or any applicable taxes. **Estimates** may be shown in different currencies from that of the saleroom for guidance only. The rate of exchange used in our printed catalogues is fixed at the latest practical date prior to the printing of the catalogue and may have changed by the time of our sale.

6 WITHDRAWAL

Christie's may, at its option, withdraw any **lot** at any time prior to or during the sale of the **lot**. Christie's has no liability to you for any decision to withdraw.

7 JEWELLERY

(a) Coloured gemstones (such as rubies, sapphires and emeralds) may have been treated to improve their look, through methods such as heating and oiling. These methods are accepted by the international jewellery trade but may make the gemstone less strong and/or require special care over time.

(b) All types of gemstones may have been improved by some method. You may request a gemmological report for any item which does not have a report if the request is made to us at least three weeks before the date of the auction and you pay the fee for the report.

(c) We do not obtain a gemmological report for every gemstone sold in our auctions. Where we do get gemmological reports from internationally accepted gemmological laboratories, such reports will be described in the catalogue. Reports from American gemmological laboratories will describe any improvement or treatment to the gemstone. Reports from European gemmological laboratories will describe any improvement or treatment only if we request that they do so, but will confirm when no improvement or treatment has been made. Because of differences in approach and technology, laboratories may not agree whether a particular gemstone has been treated, the amount of treatment or whether treatment is permanent. The gemmological laboratories will only report on the improvements or treatments known to the laboratories at the date of the report.

(d) For jewellery sales, **estimates** are based on the information in any gemmological report or, if no report is available, assume that the gemstones may have been treated or enhanced.

8 WATCHES & CLOCKS

(a) Almost all clocks and watches are repaired in their lifetime and may include parts which are not original. We do not give a **warranty** that any individual component part of any watch or clock is **authentic**. Watchbands described as "associated" are not part of the original watch and may not be **authentic**. Clocks may be sold without pendulums, weights or keys.

(b) As collectors' watches and clocks often have very fine and complex mechanisms, a general service, change of battery or further repair work may be necessary, for

which you are responsible. We do not give a **warranty** that any watch or clock is in good working order. Certificates are not available unless described in the catalogue.

(c) Most watches have been opened to find out the type and quality of movement. For that reason, watches with water resistant cases may not be waterproof and we recommend you have them checked by a competent watchmaker before use.

Important information about the sale, transport and shipping of watches and watchbands can be found in paragraph H2(g).

B REGISTERING TO BID

1 NEW BIDDERS

(a) If this is your first time bidding at Christie's or you are a returning bidder who has not bought anything from any of our salerooms within the last two years you must register at least 48 hours before an auction to give us enough time to process and approve your registration. We may, at our option, decline to permit you to register as a bidder. You will be asked for the following:

(i) for individuals: Photo identification (driving licence, national identity card or passport) and, if not shown on the ID document, proof of your current address (for example, a current utility bill or bank statement);

(ii) for corporate clients: Your Certificate of Incorporation or equivalent document(s) showing your name and registered address together with documentary proof of directors and beneficial owners; and

(iii) for trusts, partnerships, offshore companies and other business structures, please contact us in advance to discuss our requirements.

(b) We may also ask you to give us a financial reference and/or a deposit as a condition of allowing you to bid. For help, please contact our Client Services Department on +852 2760 1766.

2 RETURNING BIDDERS

We may at our option ask you for current identification as described in paragraph B1(a) above, a financial reference or a deposit as a condition of allowing you to bid. If you have not bought anything from any of our salerooms in the last two years or if you want to spend more than on previous occasions, please contact our Bids Department on +852 2978 9910 or email to bidsasia@christies.com.

3 IF YOU FAIL TO PROVIDE THE RIGHT DOCUMENTS

If in our opinion you do not satisfy our bidder identification and registration procedures including, but not limited to completing any anti-money laundering and/or anti-terrorism financing checks we may require to our satisfaction, we may refuse to register you to bid, and if you make a successful bid, we may cancel the contract for sale between you and the seller.

4 BIDDING ON BEHALF OF ANOTHER PERSON

(a) **As authorised bidder:** If you are bidding on behalf of another person, that person will need to complete the registration requirements above before you can bid, and supply a signed letter authorising you to bid for him/her.

(b) **As agent for an undisclosed principal:** If you are bidding as an agent for an undisclosed principal (the ultimate buyer(s)), you accept personal liability to pay the **purchase price** and all other sums due. Further, you warrant that:

(i) you have conducted appropriate customer due diligence on the ultimate buyer(s) of the **lot(s)** in accordance with any and all applicable anti-money

laundering and sanctions laws, consent to us relying on this due diligence, and you will retain for a period of not less than 5 years the documentation and records evidencing the due diligence;

(ii) you will make such documentation and records evidencing your due diligence promptly available for immediate inspection by an independent third-party auditor upon our written request to do so. We will not disclose such documentation and records to any third-parties unless (1) it is already in the public domain, (2) it is required to be disclosed by law, or (3) it is in accordance with anti-money laundering laws;

(iii) the arrangements between you and the ultimate buyer(s) are not designed to facilitate tax crimes;

(iv) you do not know, and have no reason to suspect, that the funds used for settlement are connected with, the proceeds of any criminal activity or that the ultimate buyer(s) are under investigation, charged with or convicted of money laundering, terrorist activities or other money laundering predicate crimes.

A bidder accepts personal liability to pay the **purchase price** and all other sums due unless it has been agreed in writing with Christie's before commencement of the auction that the bidder is acting as an agent on behalf of a named third party acceptable to Christie's and that Christie's will only seek payment from the named third party.

5 BIDDING IN PERSON

If you wish to bid in the saleroom you must register for a numbered bidding paddle at least 30 minutes before the auction. For help, please contact the Client Services Department on +852 2760 1766.

6 BIDDING SERVICES

The bidding services described below are a free service offered as a convenience to our clients and Christie's is not responsible for any error (human or otherwise), omission or breakdown in providing these services.

(A) PHONE BIDS

Your request for this service must be made no later than 24 hours prior to the auction. We will accept bids by telephone for **lots** only if our staff are available to take the bids. Telephone bids cannot be accepted for lots estimated below HK\$30,000. If you need to bid in a language other than in English, you must arrange this well before the auction. We may record telephone bids. By bidding on the telephone, you are agreeing to us recording your conversations. You also agree that your telephone bids are governed by these Conditions of Sale.

(B) INTERNET BIDS ON CHRISTIE'S LIVE™

For certain auctions we will accept bids over the Internet. Please visit www.christies.com/livebidding and click on the 'Bid Live' icon to see details of how to watch, hear and bid at the auction from your computer. As well as these Conditions of Sale, internet bids are governed by the Christie's LIVE™ terms of use which are available on www.christies.com.

(C) WRITTEN BIDS

You can find a Written Bid Form at the back of our catalogues, at any Christie's office or by choosing the sale and viewing the **lots** online at www.christies.com. We must receive your completed Written Bid Form at least 24 hours before the auction. Bids must be placed in the currency of the saleroom. The auctioneer will take reasonable steps to carry out written bids at the lowest possible price, taking into account the **reserve**. If you make a written bid on a **lot** which does not have a **reserve** and there is no higher bid than yours, we will bid on your behalf at around 50% of the **low estimate** or, if lower, the amount of your bid. If we receive written bids on a **lot** for identical amounts, and at the auction these are the highest bids on the **lot**, we will sell the **lot** to the bidder whose written bid we received first.

C AT THE SALE

1 WHO CAN ENTER THE AUCTION

We may, at our option, refuse admission to our premises or decline to permit participation in any auction or to reject any bid.

2 RESERVES

Unless otherwise indicated, all **lots** are subject to a **reserve**. We identify **lots** that are offered without **reserve** with the symbol **r** next to the **lot** number. The **reserve** cannot be more than the **lot's low estimate**.

3 AUCTIONEER'S DISCRETION

The auctioneer can at his sole option:

- refuse any bid;
- move the bidding backwards or forwards in any way he or she may decide, or change the order of the **lots**;
- withdraw any **lot**;
- divide any **lot** or combine any two or more **lots**;
- reopen or continue the bidding even after the hammer has fallen; and
- in the case of error or dispute and whether during or after the auction, to continue the bidding, determine the successful bidder, cancel the sale of the **lot**, or reoffer and resell any **lot**. If any dispute relating to bidding arises during or after the auction, the auctioneer's decision in exercise of this option is final.

4 BIDDING

The auctioneer accepts bids from:

- bidders in the saleroom;
- telephone bidders, and internet bidders through 'Christie's LIVE™' (as shown above in Section B6); and
- written bids (also known as absentee bids or commission bids) left with us by a bidder before the auction.

5 BIDDING ON BEHALF OF THE SELLER

The auctioneer may, at his or her sole option, bid on behalf of the seller up to but not including the amount of the **reserve** either by making consecutive bids or by making bids in response to other bidders. The auctioneer will not identify these as bids made on behalf of the seller and will not make any bid on behalf of the seller at or above the **reserve**. If **lots** are offered without **reserve**, the auctioneer will generally decide to open the bidding at 50% of the **low estimate** for the **lot**. If no bid is made at that level, the auctioneer may decide to go backwards at his or her sole option until a bid is made, and then continue up from that amount. In the event that there are no bids on a **lot**, the auctioneer may deem such **lot** unsold.

6 BID INCREMENTS

Bidding generally starts below the **low estimate** and increases in steps (bid increments). The auctioneer will decide at his or her sole option where the bidding should start and the bid increments. The usual bid increments are shown for guidance only on the Written Bid Form at the back of this catalogue.

7 CURRENCY CONVERTER

The saleroom video screens, Christie's LIVE™ and Christie's website may show bids in some other major currencies from that of the saleroom. Any conversion is for guidance only and we cannot be bound by any rate of exchange used by Christie's. Christie's is not responsible for any error (human or otherwise), omission or breakdown in providing these services.

8 SUCCESSFUL BIDS

Unless the auctioneer decides to use his or her discretion as set out in paragraph C3 above, when the auctioneer's hammer strikes, we have accepted the last bid. This means a contract for sale has been formed between the seller and the successful bidder. We will issue an invoice

only to the registered bidder who made the successful bid. While we send out invoices by post and/or email after the auction, we do not accept responsibility for telling you whether or not your bid was successful. If you have bid by written bid, you should contact us by telephone or in person as soon as possible after the auction to get details of the outcome of your bid to avoid having to pay unnecessary storage charges.

9 LOCAL BIDDING LAWS

You agree that when bidding in any of our sales that you will strictly comply with all local laws and regulations in force at the time of the sale for the relevant sale site.

D THE BUYER'S PREMIUM, TAXES

1 THE BUYER'S PREMIUM

In addition to the **hammer price**, the successful bidder agrees to pay us a **buyer's premium** on the **hammer price** of each **lot** sold. On all **lots** we charge 25% of the **hammer price** up to and including HK\$1,200,000, 20% on that part of the **hammer price** over HK\$1,200,000 and up to and including HK\$20,000,000, and 12% of that part of the **hammer price** above HK\$20,000,000.

For wine there is a flat rate of 22.5% of the **hammer price** of each lot sold.

2 TAXES

The successful bidder is responsible for any applicable tax including any VAT, sales or compensating use tax or equivalent tax wherever such taxes may arise on the **hammer price** and the **buyer's premium**. It is the buyer's responsibility to ascertain and pay all taxes due. In all circumstances Hong Kong law takes precedence. Christie's recommends you obtain your own independent tax advice.

For **lots** Christie's ships to the United States, a state sales or use tax may be due on the **hammer price**, **buyer's premium** and shipping costs on the **lot**, regardless of the nationality or citizenship of the purchaser. Christie's is currently required to collect sales tax for lots it ships to the following states: New York. The applicable sales tax rate will be determined based upon the state, county, or locale to which the **lot** will be shipped. Successful bidders claiming an exemption from sales tax must provide appropriate documentation to Christie's prior to the release of the **lot**. For shipments to those states for which Christie's is not required to collect sales tax, a successful bidder may be required to remit use tax to that state's taxing authorities. Christie's recommends you obtain your own independent tax advice with further questions.

E WARRANTIES

1 SELLER'S WARRANTIES

For each **lot**, the seller gives a **warranty** that the seller:

- is the owner of the **lot** or a joint owner of the **lot** acting with the permission of the other co-owners or, if the seller is not the owner or a joint owner of the **lot**, has the permission of the owner to sell the **lot**, or the right to do so in law; and
 - has the right to transfer ownership of the **lot** to the buyer without any restrictions or claims by anyone else.
- If either of the above **warranties** are incorrect, the seller shall not have to pay more than the **purchase price** (as defined in paragraph F1(a) below) paid by you to us. The seller will not be responsible to you for any reason for loss of profits or business, expected savings, loss of opportunity or interest, costs, damages, **other damages** or expenses. The seller gives no **warranty** in relation to any **lot** other than as set out above and, as far as the seller is allowed by law, all **warranties** from the seller to you, and all other obligations upon the seller which may be added to this agreement by law, are excluded.

2 OUR AUTHENTICITY WARRANTY

We warrant, subject to the terms below, that the **lots** in our sales are **authentic** (our "authenticity warranty"). If, within 5 years of the date of the auction, you satisfy us that your **lot** is not **authentic**, subject to the terms below, we will refund the **purchase price** paid by you. The meaning of **authentic** can be found in the glossary at the end of these Conditions of Sale. The terms of the **authenticity warranty** are as follows:

(a) It will be honoured for a period of 5 years from the date of the auction. After such time, we will not be obligated to honour the **authenticity warranty**.

(b) It is given only for information shown in **UPPERCASE type** in the first line of the **catalogue description** (the "**Heading**"). It does not apply to any information other than in the **Heading** even if shown in **UPPERCASE type**.

(c) The **authenticity warranty** does not apply to any **Heading** or part of a **Heading** which is **qualified**. **Qualified** means limited by a clarification in a **lot's catalogue description** or by the use in a **Heading** of one of the terms listed in the section titled **Qualified Headings** on the page of the catalogue headed "Important Notices and Explanation of Cataloguing Practice". For example, use of the term "ATTRIBUTED TO..." in a **Heading** means that the **lot** is in Christie's opinion probably a work by the named artist but no **warranty** is provided that the **lot** is the work of the named artist. Please read the full list of **Qualified Headings** and a **lot's full catalogue description** before bidding.

(d) The **authenticity warranty** applies to the **Heading** as amended by any **Saleroom Notice**.

(e) The **authenticity warranty** does not apply where scholarship has developed since the auction leading to a change in generally accepted opinion. Further, it does not apply if the **Heading** either matched the generally accepted opinion of experts at the date of the sale or drew attention to any conflict of opinion.

(f) The **authenticity warranty** does not apply if the **lot** can only be shown not to be **authentic** by a scientific process which, on the date we published the catalogue, was not available or generally accepted for use, or which was unreasonably expensive or impractical, or which was likely to have damaged the **lot**.

(g) The benefit of the **authenticity warranty** is only available to the original buyer shown on the invoice for the **lot** issued at the time of the sale and only if the original buyer has owned the **lot** continuously between the date of the auction and the date of claim. It may not be transferred to anyone else.

(h) In order to claim under the **authenticity warranty** you must:

(i) give us written details, including full supporting evidence, of any claim within 5 years of the date of the auction;

(ii) at Christie's option, we may require you to provide the written opinions of two recognised experts in the field of the **lot** mutually agreed by you and us in advance confirming that the **lot** is not **authentic**. If we have any doubts, we reserve the right to obtain additional opinions at our expense; and

(iii) return the **lot** at your expense to the saleroom from which you bought it in the **condition** it was in at the time of sale.

(i) Your only right under this **authenticity warranty** is to cancel the sale and receive a refund of the **purchase price** paid by you to us. We will not, in any circumstances, be required to pay you more than the **purchase price** nor will we be liable for any loss of profits or business, loss of opportunity or value, expected savings or interest, costs, damages, **other damages** or expenses.

(j) **Books**. Where the **lot** is a book, we give an additional **warranty** for 14 days from the date of the sale that if on collation any **lot** is defective in text or

illustration, we will refund your **purchase price**, subject to the following terms:

(a) This additional **warranty** does not apply to:

(i) the absence of blanks, half titles, tissue guards or advertisements, damage in respect of bindings, stains, spotting, marginal tears or other defects not affecting completeness of the text or illustration;

(ii) drawings, autographs, letters or manuscripts, signed photographs, music, atlases, maps or periodicals;

(iii) books not identified by title;

(iv) **lots** sold without a printed **estimate**;

(v) books which are described in the catalogue as sold not subject to return; or

(vi) defects stated in any **condition report** or announced at the time of sale.

(b) To make a claim under this paragraph you must give written details of the defect and return the **lot** to the sale room at which you bought it in the same **condition** as at the time of sale, within 14 days of the date of the sale.

(k) **South East Asian Modern and Contemporary Art and Chinese Calligraphy and Painting**.

In these categories, the **authenticity warranty** does not apply because current scholarship does not permit the making of definitive statements. Christie's does, however, agree to cancel a sale in either of these two categories of art where it has been proven the **lot** is a forgery. Christie's will refund to the original buyer the **purchase price** in accordance with the terms of Christie's **authenticity warranty**, provided that the original buyer notifies us with full supporting evidence documenting the forgery claim within twelve (12) months of the date of the auction. Such evidence must be satisfactory to us that the **lot** is a forgery in accordance with paragraph E2(h)(ii) above and the **lot** must be returned to us in accordance with E2h(iii) above. Paragraphs E2(b), (c), (d), (e), (f) and (g) and (i) also apply to a claim under these categories.

(l) **GUARANTEE IN RELATION TO WINES AND SPIRITS**

(a) Subject to the obligations accepted by Christie's, none of the seller, Christie's, its employees or agents is responsible for the correctness of any statement as to the authorship, origin, date, age, attribution, genuineness or provenance of any **lot**, for any other error of description of for any fault or defect in any **lot** and no warranty whatsoever is given by the seller, Christie's, its employees or agents in respect of any **lot** and any express or implied condition or warranty is hereby excluded;

(b) If, (1) within twenty-one days of the date of the auction, Christie's has received notice in writing from the buyer of any **lot** that in his view the **lot** was at the date of the auction short or ullaged or that any statement of opinion in the catalogue was not well founded, (2) within fourteen days of such notice, Christie's has the **lots** in its possession in the same condition as at the date of the auction and (3) within a reasonable time thereafter, the buyer satisfies Christie's that the **lot** was as notified in writing by the buyer (as above) and that the buyer is able to transfer a good and marketable title to the **lot** free from any lien or encumbrance, Christie's will set aside the sale and refund to the buyer any amount paid by the buyer in respect of the **lot** provided that the buyer shall have no rights under this Condition if:

(i) the defect is mentioned in the catalogue; or

(ii) the catalogue description at the date of the auction was in accordance with the then generally accepted opinion of scholars or experts or fairly indicated there to be a conflict of such opinion; or

(iii) it can be established that the **lot** was as notified in writing by the buyer (as above) only by means of a scientific process not generally accepted for use until after the publication of the catalogue or by means of a process which at the date of the auction was unreasonably expensive or impracticable or likely to have caused damage to the **lot**. (See also notes on ullages and corks);

(c) the buyer shall not be entitled to claim under this Condition for more than the amount paid by him for the **lot** and in particular shall have no claim for any loss, consequential loss or damage whether direct or indirect suffered by him;

(d) the benefit of this guarantee shall not be assignable and shall rest solely and exclusively in the buyer who shall be the person to whom the original invoice was made out by Christie's in respect of the **lot** when sold and who has since the sale retained uninterrupted, unencumbered ownership thereof.

F PAYMENT

1 HOW TO PAY

(a) Immediately following the auction, you must pay the **purchase price** being:

(i) the **hammer price**; and

(ii) the **buyer's premium**; and

(iii) any duties, goods, sales, use, compensating or service tax.

Payment is due no later than by the end of the 7th calendar day following the date of the auction (the "**due date**").

(b) We will only accept payment from the registered bidder. Once issued, we cannot change the buyer's name on an invoice or re-issue the invoice in a different name. You must pay immediately even if you want to export the **lot** and you need an export licence.

(c) You must pay for **lots** bought at Christie's in Hong Kong in the currency stated on the invoice in one of the following ways:

(i) Christie's is pleased to offer clients the option of viewing invoices, paying and arranging shipping online through MyChristie's. To log in, or if you have yet to create an online account, please go to: www.christies.com/MyChristies. While this service is available for most lots, payment and shipping must be arranged offline for some items. Please contact Post-Sale Services directly to coordinate.

(ii) Wire transfer

You must make payments to:

HSBC

Head Office

1 Queen's Road, Central, Hong Kong

Bank code: 004

Account No. 062-305438-001

Account Name: Christie's Hong Kong Limited

SWIFT: HSBCHKHKKH

(iii) Credit Card.

We accept most major credit cards subject to certain conditions. We accept payments in person by credit card up to HK\$1,000,000 per auction sale although conditions and restrictions apply. China Union Pay is accepted with no limits on amounts. To make a "cardholder not present" (CNP) payment, we accept payment up to HK\$500,000 per auction sale. CNP payments cannot be accepted by all salerooms and are subject to certain restrictions. Details of the conditions and restrictions applicable to credit card payments are available from our Post-Sale Services Department, whose details are set out in paragraph (d) below.

(iv) Cash

We accept cash subject to a maximum of HKD80,000 per buyer per year at our Post-Sale Services Department only (subject to conditions).

(v) Banker's draft

You must make these payable to Christie's Hong Kong Limited and there may be conditions.

(vi) Cheque

You must make cheques payable to Christie's Hong Kong Limited. Cheques must be from accounts in Hong Kong dollar from a Hong Kong bank.

(d) You must quote the sale number, your invoice number and client number when making a payment. All

payments sent by post must be sent to: Christie's, Post-Sale Services Department, 22nd Floor Alexandra House, 18 Chater Road, Central, Hong Kong.

(e) For more information please contact our Post-Sale Services Department by phone on +852 2760 1766 or email to postsaleasia@christies.com.

2 TRANSFERRING OWNERSHIP TO YOU

You will not own the **lot** and ownership of the **lot** will not pass to you until we have received full and clear payment of the **purchase price**, even in circumstances where we have released the **lot** to the buyer.

3 TRANSFERRING RISK TO YOU

The risk in and responsibility for the **lot** will transfer to you from whichever is the earlier of the following:

- (a) When you collect the **lot**; or
- (b) At the end of the 35th day following the date of the auction or, if earlier, the date the lot is taken into care by a third party warehouse as set out on the page headed "Christie's Hong Kong Wine Storage and Collection" unless we have agreed otherwise with you in writing.

4 WHAT HAPPENS IF YOU DO NOT PAY

(a) If you fail to pay us the **purchase price** in full by the **due date**, we will be entitled to do one or more of the following (as well as enforce our rights under paragraph F5 and any other rights or remedies we have by law):

- (i) to charge interest from the due date at a rate of 7% a year above the 3-month HIBOR rate from time to time on the unpaid amount due;
 - (ii) we can cancel the sale of the **lot**. If we do this, we may sell the **lot** again, publically or privately on such terms we shall think necessary or appropriate, in which case you must pay us any shortfall between the **purchase price** and the proceeds from the resale. You must also pay all costs, expenses, losses, damages and legal fees we have to pay or may suffer and any shortfall in the seller's commission on the resale;
 - (iii) we can pay the seller an amount up to the net proceeds payable in respect of the amount bid by your default in which case you acknowledge and understand that Christie's will have all of the rights of the seller to pursue you for such amounts;
 - (iv) we can hold you legally responsible for the **purchase price** and may begin legal proceedings to recover it together with other losses, interest, legal fees and costs as far as we are allowed by law;
 - (v) we can take what you owe us from any amounts which we or any company in the **Christie's Group** may owe you (including any deposit or other part-payment which you have paid to us);
 - (vi) we can, at our option, reveal your identity and contact details to the seller;
 - (vii) we can reject at any future auction any bids made by you or on your behalf or to obtain a deposit from you before accepting any bids;
 - (viii) to exercise all the rights and remedies of a person holding security over any property in our possession owned by you, whether by way of pledge, security interest or in any other way as permitted by the law of the place where such property is located. You will be deemed to have granted such security to us and we may retain such property as collateral security for your obligations to us; and
 - (ix) we can take any other action we see necessary or appropriate.
- (b) If you owe money to us or to another **Christie's Group** company, we can use any amount you do pay, including any deposit or other part-payment you have made to us, or which we owe you, to pay off any amount you owe to us or another **Christie's Group** company for any transaction.
- (c) If you make payment in full after the **due date**, and we choose to accept such payment we may charge you storage and transport costs from the date that is

36 calendar days following the auction in accordance with paragraphs G(d)(i) and (ii). In such circumstances paragraph G(d)(iv) shall apply.

5 KEEPING YOUR PROPERTY

If you owe money to us or to another **Christie's Group** company, as well as the rights set out in F4 above, we can use or deal with any of your property we hold or which is held by another **Christie's Group** company in any way we are allowed to by law. We will only release your property to you after you pay us or the relevant **Christie's Group** company in full for what you owe. However, if we choose, we can also sell your property in any way we think appropriate. We will use the proceeds of the sale against any amounts you owe us and we will pay any amount left from that sale to you. If there is a shortfall, you must pay us any difference between the amount we have received from the sale and the amount you owe us.

G WINE COLLECTION AND STORAGE

- (a) We ask that you collect purchased **lots** promptly following the auction (**but note that you may not collect any lot until you have made full and clear payment of all amounts due to us**).
- (b) Information on collecting **lots** is set out on the Christie's Hong Kong Wine Storage and Collection page.
- (c) If you do not collect any **lot** promptly following the auction we can, at our option, remove the lot to another Christie's location or an affiliate or third party warehouse.
- (d) If you do not collect a **lot** by the end of the 35th day following the date of the auction, unless otherwise agreed in writing:
- (i) we will charge you storage costs from that date.
 - (ii) we can, at our option, move the **lot** to or within an affiliate or third party warehouse and charge you transport costs and handling fees for doing so.
 - (iii) we may sell the **lot** in any commercially reasonable way we think appropriate.
 - (iv) the storage terms which can be found at www.christies.com/storage shall apply.
 - (v) Nothing in this paragraph is intended to limit our rights under paragraph F4.

H TRANSPORT AND SHIPPING

1 TRANSPORT AND SHIPPING

We will enclose a transport and shipping form with each invoice sent to you. You must make all transport and shipping arrangements. However, we can arrange to pack, transport and ship your property if you ask us to and pay the costs of doing so. We recommend that you ask us for an **estimate**, especially for any large items or items of high value that need professional packing before you bid. We may also suggest other handlers, packers, transporters or experts if you ask us to do so. For more information, please contact Post-Sale Services Department on +852 2760 1766 or email to postsaleasia@christies.com. We will take reasonable care when we are handling, packing, transporting and shipping a **lot**. However, if we recommend another company for any of these purposes, we are not responsible for their acts, failure to act or neglect.

2 EXPORT AND IMPORT

Any **lot** sold at auction may be affected by laws on exports from the country in which it is sold and the import restrictions of other countries. Many countries require a declaration of export for property leaving the country and/or an import declaration on entry of property into the country. Local laws may prevent you from importing a **lot** or may prevent you selling a **lot** in the country you import it into.

(a) You alone are responsible for getting advice about and meeting the requirements of any laws or regulations which apply to exporting or importing any **lot** prior to bidding. If you are refused a licence or there is a delay

in getting one, you must still pay us in full for the **lot**. We may be able to help you apply for the appropriate licences if you ask us to and pay our fee for doing so. However, we cannot guarantee that you will get one. For more information, please contact Post-Sale Services Department on +852 2760 1766 or email to postsaleasia@christies.com.

(b) Lots made of protected species

Lots made of or including (regardless of the percentage) endangered and other protected species of wildlife are marked with the symbol - in the catalogue. This material includes, among other things, ivory, tortoiseshell, crocodile skin, rhinoceros horn, whalebone certain species of coral, and rosewood. You should check the relevant customs laws and regulations before bidding on any **lot** containing wildlife material if you plan to import the **lot** into another country. Several countries refuse to allow you to import property containing these materials, and some other countries require a licence from the relevant regulatory agencies in the countries of exportation as well as importation. In some cases, the **lot** can only be shipped with an independent scientific confirmation of species and/or age and you will need to obtain these at your own cost. If a **lot** contains elephant ivory, or any other wildlife material that could be confused with elephant ivory, (for example, mammoth ivory, walrus ivory, helmeted hornbill ivory) please see further important information in paragraph (c) if you are proposing to import the **lot** into the USA. We will not be obliged to cancel your purchase and refund the **purchase price** if your **lot** may not be exported, imported or it is seized for any reason by a government authority. It is your responsibility to determine and satisfy the requirements of any applicable laws or regulations relating to the export or import of property containing such protected or regulated material.

(c) US import ban on African elephant ivory

The USA prohibits the import of ivory from the African elephant. Any **lot** containing elephant ivory or other wildlife material that could be easily confused with elephant ivory (for example, mammoth ivory, walrus ivory, helmeted hornbill ivory) can only be imported into the US with results of a rigorous scientific test acceptable to Fish & Wildlife, which confirms that the material is not African elephant ivory. Where we have conducted such rigorous scientific testing on a **lot** prior to sale, we will make this clear in the lot description. In all other cases, we cannot confirm whether a **lot** contains African elephant ivory, and you will buy that **lot** at your own risk and be responsible for any scientific test or other reports required for import into the USA at your own cost. If such scientific test is inconclusive or confirms the material is from the African elephant, we will not be obliged to cancel your purchase and refund the **purchase price**.

(d) Lots of Iranian origin

Some countries prohibit or restrict the purchase and/or import of Iranian-origin "works of conventional craftsmanship" (works that are not by a recognized artist and/or that have a function, for example: carpets, bowls, ewers, tiles, ornamental boxes). For example, the USA prohibits the import of this type of property and its purchase by US persons (wherever located). Other countries, such as Canada, only permit the import of this property in certain circumstances. As a convenience to buyers, Christie's indicates under the title of a **lot** if the **lot** originates from Iran (Persia). It is your responsibility to ensure you do not bid on or import a **lot** in contravention of the sanctions or trade embargoes that apply to you.

(e) Gold

Gold of less than 18ct does not qualify in all countries as 'gold' and may be refused import into those countries as 'gold'.

(f) **Watches**

Many of the watches offered for sale in this catalogue are pictured with straps made of endangered or protected animal materials such as alligator or crocodile. These **lots** are marked with the symbol Ψ in the catalogue. These endangered species straps are shown for display purposes only and are not for sale. Christie's will remove and retain the strap prior to shipment from the sale site. At some sale sites, Christie's may, at its discretion, make the displayed endangered species strap available to the buyer of the **lot** free of charge if collected in person from the sale site within 1 year of the date of the sale. Please check with the department for details on a particular **lot**.

For all symbols and other markings referred to in paragraph H2, please note that **lots** are marked as a convenience to you, but we do not accept liability for errors or for failing to mark **lots**.

I OUR LIABILITY TO YOU

(a) We give no **warranty** in relation to any statement made, or information given, by us or our representatives or employees, about any **lot** other than as set out in the **authenticity warranty** and, as far as we are allowed by law, all **warranties** and other terms which may be added to this agreement by law are excluded. The seller's **warranties** contained in paragraph E1 are their own and we do not have any liability to you in relation to those **warranties**.

(b) (i) We are not responsible to you for any reason (whether for breaking this agreement or any other matter relating to your purchase of, or bid for, any **lot**) other than in the event of fraud or fraudulent misrepresentation by us or other than as expressly set out in these conditions of sale; and

(ii) We do not give any representation, warranty or guarantee or assume any liability of any kind in respect of any **lot** with regard to merchantability, fitness for a particular purpose, description, size, quality, condition, attribution, authenticity, rarity, importance, medium, provenance, exhibition history, literature, or historical relevance. Except as required by local law, any warranty of any kind is excluded by this paragraph.

(c) In particular, please be aware that our written and telephone bidding services, Christie's LIVE™, **condition** reports, currency converter and saleroom video screens are free services and we are not responsible to you for any error (human or otherwise), omission, breakdown, or delay, unavailability, suspension or termination of any of these services.

(d) We have no **responsibility** to any person other than a buyer in connection with the purchase of any **lot**.

(e) If, in spite of the terms in paragraphs (a) to (d) or E2(i) above, we are found to be liable to you for any reason, we shall not have to pay more than the **purchase price** paid by you to us. We will not be responsible to you for any reason for loss of profits or business, loss of opportunity or value, expected savings or interest, costs, damages, or expenses.

J OTHER TERMS

1 OUR ABILITY TO CANCEL

In addition to the other rights of cancellation contained in this agreement, we can cancel a sale of a **lot** if we reasonably believe that completing the transaction is, or may be, unlawful or that the sale places us or the seller under any liability to anyone else or may damage our reputation.

2 RECORDINGS

We may videotape and record proceedings at any auction. We will keep any personal information confidential, except to the extent disclosure is required by law. However, we may, through this process, use or share these recordings with another **Christie's**

Group company and marketing partners to analyse our customers and to help us to tailor our services for buyers. If you do not want to be videotaped, you may make arrangements to make a telephone or written bid or bid on Christie's LIVE™ instead. Unless we agree otherwise in writing, you may not videotape or record proceedings at any auction.

3 COPYRIGHT

We own the copyright in all images, illustrations and written material produced by or for us relating to a **lot** (including the contents of our catalogues unless otherwise noted in the catalogue). You cannot use them without our prior written permission. We do not offer any guarantee that you will gain any copyright or other reproduction rights to the **lot**.

4 ENFORCING THIS AGREEMENT

If a court finds that any part of this agreement is not valid or is illegal or impossible to enforce, that part of the agreement will be treated as being deleted and the rest of this agreement will not be affected.

5 TRANSFERRING YOUR RIGHTS AND RESPONSIBILITIES

You may not grant a security over or transfer your rights or responsibilities under these terms on the contract of sale with the buyer unless we have given our written permission. This agreement will be binding on your successors or estate and anyone who takes over your rights and responsibilities.

6 TRANSLATIONS

If we have provided a translation of this agreement, we will use the English version in deciding any issues or disputes which arise under this agreement.

7 PERSONAL INFORMATION

We will hold and process your personal information and may pass it to another **Christie's Group** company for use as described in, and in line with, our privacy policy at www.christies.com.

8 WAIVER

No failure or delay to exercise any right or remedy provided under these Conditions of Sale shall constitute a waiver of that or any other right or remedy, nor shall it prevent or restrict the further exercise of that or any other right or remedy. No single or partial exercise of such right or remedy shall prevent or restrict the further exercise of that or any other right or remedy.

9 LAW AND DISPUTES

The rights and obligations of the parties with respect to these Conditions of Sale, the conduct of the auction and any matters connected with any of the foregoing shall be governed and interpreted by the Hong Kong laws. By bidding at auction, whether present in person or by agent, by written bid, telephone or other means, the buyer shall be deemed to have accepted these Conditions and submitted, for the benefit of Christie's, to the exclusive jurisdiction of the Hong Kong courts, and also accepted that Christie's also has the right to pursue remedies in any other jurisdiction in order to recover any outstanding sums due from the buyer.

10 REPORTING ON WWW.CHRISTIES.COM

Details of all **lots** sold by us, including **catalogue descriptions** and prices, may be reported on www.christies.com. Sales totals are **hammer price** plus **buyer's premium** and do not reflect costs, financing fees, or application of buyer's or seller's credits. We regret that we cannot agree to requests to remove these details from www.christies.com.

K GLOSSARY

authentic : a genuine example, rather than a copy or forgery of:

(i) the work of a particular artist, author or manufacturer, if the **lot** is described in the **Heading** as the work of that artist, author or manufacturer;

(ii) a work created within a particular period or culture, if the **lot** is described in the **Heading** as a work created during that period or culture;

(iii) a work for a particular origin source if the **lot** is described in the **Heading** as being of that origin or source; or

(iv) in the case of gems, a work which is made of a particular material, if the **lot** is described in the **Heading** as being made of that material.

authenticity warranty : the guarantee we give in this agreement that a **lot** is **authentic** as set out in section E2 of this agreement.

buyer's premium : the charge the buyer pays us along with the **hammer price**.

catalogue description : the description of a **lot** in the catalogue for the auction, as amended by any saleroom notice.

Christie's Group : Christie's International Plc, its subsidiaries and other companies within its corporate group.

condition : the physical **condition** of a **lot**.

due date : has the meaning given to it paragraph F1(a).

estimate : the price range included in the catalogue or any saleroom notice within which we believe a **lot** may sell. **Low estimate** means the lower figure in the range and **high estimate** means the higher figure. The **mid estimate** is the midpoint between the two.

hammer price : the amount of the highest bid the auctioneer accepts for the sale of a **lot**.

Heading : has the meaning given to it in paragraph E2.

lot : an item to be offered at auction (or two or more items to be offered at auction as a group).

other damages : any special, consequential, incidental or indirect damages of any kind or any damages which fall within the meaning of 'special', 'incidental' or 'consequential' under local law.

purchase price : has the meaning given to it in paragraph F1(a).

provenance : the ownership history of a **lot**.

qualified : has the meaning given to it in paragraph E2 and **Qualified Headings** means the section headed **Qualified Headings** on the page of the catalogue headed 'Important Notices and Explanation of Cataloguing Practice'.

reserve : the confidential amount below which we will not sell a **lot**.

saleroom notice : a written notice posted next to the **lot** in the saleroom and on www.christies.com, which is also read to prospective telephone bidders and notified to clients who have left commission bids, or an announcement made by the auctioneer either at the beginning of the sale, or before a particular **lot** is auctioned.

UPPER CASE type : means having all capital letters.

warranty : a statement or representation in which the person making it guarantees that the facts set out in it are correct.

業務規定 · 買方須知

業務規定

業務規定和重要通知及目錄編列方法之說明列明佳士得拍賣刊載在本目錄中**拍賣品**的條款。通過登記競投和/或在拍賣會中競投即表示您同意接受這些條款，因此，您須在競投之前仔細閱讀這些條款。下述粗體字體詞語的解釋在尾部詞匯表列明。

除非佳士得擁有**拍賣品**所有權（以 Δ 標示），佳士得為賣方的代理人。

A. 拍賣之前

1. 拍賣品描述

- 目錄描述部分使用的某些詞匯有特殊意義。詳情請見構成條款部分的重要通知及目錄編列方法之說明。對目錄內的標識的解釋，請見本目錄內“本目錄中使用的各類標識”。
- 本公司在本目錄中對任何**拍賣品**的描述，**拍賣品狀況**報告及其它陳述（不管是口頭還是書面），包括**拍賣品性質**或**狀況**、藝術家、時期、材料、概略尺寸或來源均屬我們意見之表述，而不應被作為事實之陳述。我們不像專業的歷史學家及學者那樣進行深入的研究。所有的尺寸及重量僅為粗略估計。

2. 對於**拍賣品**描述佳士得所負的責任

我們不對**拍賣品**的性質提供任何保證，除了下述第 E2 段的**真品保證**以及第 I 段另有約定。

3. 狀況

- 在我們拍賣會上拍賣的**拍賣品狀況**可因年代、先前損壞、修復、修理及損耗等因素而差異甚大。其性質即意味著幾乎不可能處於完美的**狀況**。**拍賣品**是按照其在拍賣之時的情況以“現狀”出售，而且不包括佳士得或賣方的任何陳述或保證或對於**狀況**的任何形式的責任承擔。
- 在本目錄條目或**狀況**報告中提及**狀況**不同於對**狀況**的完整描述，圖片可能不會清晰展示出**拍賣品**。**拍賣品**的色彩和暗暗度在印刷品或螢幕上看起來可能會與實體檢查時的情況不同。**狀況**報告可協助您評估**拍賣品**的**狀況**。為方便賣方，**狀況**報告為免費提供，僅作為指引。**狀況**報告提供了我們的意見，但是可能未指出所有的缺陷、內在瑕疵、修復、更改及改造，因為我們的僱員不是專業修復或維護人員。出於這個原因，他們不能替代您親自檢查**拍賣品**或您自己尋求的專業意見。賣方有責任確保自己已經要求提供、收悉及考慮了任何**狀況**報告。

4. 拍賣之前檢查**拍賣品**

- 如果您計劃競投一件**拍賣品**，應親自或通過具有專業知識之代表檢視，以確保您接受**拍賣品**描述及**狀況**。我們建議您從專業修復人員或其它專業顧問那裏索取意見。
- 拍賣之前的檢視免費向公眾開放。在拍賣之前的檢視或通過預約，我們的專家可在場內回答問題。

5. 估價

估價是基於**拍賣品**的**狀況**、稀有程度、質量、來源及類似物品的近期拍賣決定。**估價**可能會改變。您或任何其他人在任何情況下都不可能依賴**估價**，將其作為**拍賣品**的實際售價的預測或保證。**估價**不包括買方酬金或任何適用的稅費。**估價**可能以拍賣場當地貨幣以外的貨幣顯示並僅作指引。本目錄使用的貨幣兌換率是根據最近目錄印時的兌換率設定，所以可能與拍賣當日兌換率有差別。

6. 撤回

佳士得有權單方面決定在**拍賣品**拍賣過程中或拍賣之前的任何時間將**拍賣品**撤回。佳士得無須就任何撤回決定向您承擔責任。

7. 珠寶

- 有色寶石（如紅寶石、藍寶石及綠寶石）可能經過處理以改良外觀，包括加熱及上油等方法。這些方法都被國際珠寶行業認可，但是經處理的寶石的硬度可能會降低及/或在日後需要特殊的保養。
- 所有類型的寶石均可能經過某些改良處理。如果某件**拍賣品**沒有報告，您可以在拍賣日之前至少提前三周向我們要求寶石鑒定報告，報告的費用由您支付。
- 我們不會為每件拍賣的寶石索取鑒定報告。若我們有從國際認可的寶石鑒定實驗室取得鑒定報告，我們會在目錄中提及。從美國寶石鑒定實驗室發出的鑒定報告會描述對寶石的改良或處理。歐洲寶石鑒定實驗室的報告僅在我們要求的時候，才會提及對寶石的改良及處理，但是該報告會確認該寶石沒有被改良或處理。因各實驗室

使用方法和技術的差異，對某寶石是否處理過、處理的程度或處理是否為永久性，都可能持不同意見。寶石鑒定實驗室僅對報告作出日之前實驗室所知悉的改進及處理進行報告。

- 對於珠寶銷售來說，**估價**是以寶石鑒定報告中的信息為基礎，如果沒有報告，就會認為寶石可能已經被處理或提升過。

8. 鐘錶

- 幾乎所有的鐘錶在使用期內都被修理過，可能都含有非原裝零部件。我們不能保證任何鐘錶的任何個別零部件都是原裝。被陳述為“關聯”字樣的錶帶不是原裝錶的部分，可能不是**真品**。拍賣的鐘可能跟隨沒有鐘繩、鐘錘或鑰匙出售。
- 收藏家等級的鐘錶經常有非常精細複雜的機械構造，可能需要一般保養服務、更換電池或進一步的修理工作，而這些都由買方負責。我們不保證每一隻鐘錶都是在良好運作狀態。除非目錄中有提及，我們不提供證書。
- 大多數的錶帶被打開過查看機芯的型號及質量。因為這個原因，帶有防水錶殼的錶可能不能防水，在使用之前我們建議您讓專業鐘錶師事先檢驗。手錶及錶帶的拍賣及運送方面的重要信息，請見第 H2(g) 段。

B. 登記競投

1. 新競投人

- 如果您這是您第一次在佳士得競投，或者您曾參與我們的拍賣，但在過去兩年內未曾從任何佳士得拍賣場成功競投過任何東西，您必須在拍賣之前至少 48 個小時登記，以給我們足夠的時間來處理及批准您的登記。我們有權單方面不允許您登記成為競投人。您需提供以下資料：
 - 個人客戶：帶有照片的身份證明（駕照執照、國民身份證或護照），如果身份證明文件上沒有顯示，您當前的住址證明（如：當前的公共事業費賬單或銀行對賬單）。
 - 公司客戶：顯示名稱及注册地址的公司註冊證明或類似文件，以及董事和受益股東的文件證明。
 - 信託、合夥、離岸公司及其它業務結構，請提前聯繫我們商談要求。
- 我們可能要求您向我們提供財務證明及/或押金作為許可您競投的條件。如需幫助，請聯繫我們的客戶服務部：+852 2760 1766。

2. 再次參與競投的客人

我們可選擇要求您提供以上 B1(a) 段所提及的現時身份證明，財務證明及/或押金作為許可您競投的條件。如果您過去兩年中沒有從我們的拍賣會成功投得**拍賣品**，或者您本次擬出價金額高於過往，請聯繫我們的投標部：+852 2978 9910 或電郵至 bidsasia@christies.com。

3. 如果您未能提供正確的文件

如果我們認為，您未能滿足我們對競投者身份及登記手續的要求，包括但不限於完成及滿足本公司可能要求進行的所有反洗黑錢和/或反恐怖主義財政審查，我們可能會不允許您登記競投，而如果您成功投得**拍賣品**，我們可能撤銷您與賣方之間的買賣合約。

4. 代表他人競投

- 作為授權競投人**：如果您代表他人競投，在競投前，委託人需要完成以上的登記手續及提供已簽署的授權書，授權您代表其競投。
- 作為隱名委托人的代理人**：如果您以代理人身份為隱名委托人（最終的買方）進行競投，您同意承擔支付**購買款項**和其他應付款項的個人責任。並且，您保證：
 - 您已經根據所有適用的反洗黑錢及制裁法律對**拍賣品**的最終的買方進行必要的客戶盡職調查，同意我們依賴該盡職調查。並且，您將在不少於 5 年的期間裏保存證明盡職調查的文件和記錄。
 - 您在收到我們書面要求後可以將證明盡職調查的文件和記錄立即提供給獨立第三方審計人員即時查閱。我們不會向任何第三方披露上述文件和記錄，除非 (1) 它已經在公共領域存在，(2) 根據法律要求須被披露，(3) 符合反洗黑錢法律規定。
 - 您和最終的買方之間的安排不是為了便於任何涉稅犯罪。
 - 您不知曉並且沒有理由懷疑用於結算的資金和任何犯罪收入有關或最終的買方因洗黑錢、恐怖活動或其他基於洗黑錢的犯罪而被調查，被起訴或被定罪。

除非競投人和佳士得在拍賣開始前書面同意競投人僅作為佳士得認可並指定的第三方的代理參與競投並且佳士得只會向

該指定第三方收取付款，競投人同意就繳付**購買款項**和所有其他應付款項負上個人法律責任。

5. 親自出席競投

如果您希望在拍賣現場競投，必須在拍賣舉行前至少 30 分鐘辦理登記手續，並索取競投號碼牌。如需協助，請聯繫客戶服務部：+852 2760 1766。

6. 競投服務

下述的競投服務是為方便客戶而設，如果在提供該服務出現任何錯誤（人為或其它），遺漏或故障，佳士得均不負上任何責任。

(A) 電話競投

您必須在拍賣開始前至少 24 小時辦理申請電話競投。佳士得只會能夠安排人員協助電話競投的情況下接受電話競投。估價低於港幣 30,000 元之**拍賣品**將不接受電話競投。若需要以英語外的其他語言進行競投，須儘早在拍賣之前預先安排。電話競投將可被錄音。以電話競投即代表您同意其對話被錄音。您同意電話競投受業務規定管限。

(B) 在 Christie's s LIVE™ 網絡競投

在某些拍賣，我們會接受網絡競投。請登入 www.christies.com/livebidding，點擊“現場競投”圖標，瞭解如何從電腦聆聽及觀看拍賣及參與競投。網絡競投受業務規定及 Christie's Live™ 使用條款的管限，詳情請見 www.christies.com 網站。

(C) 書面競投

您可於本目錄，任何佳士得辦公室或通過 www.christies.com 選擇拍賣並查看**拍賣品**取得書面競投表格。您必須在拍賣開始前至少 24 小時提交已經填妥的書面競投表格。投標必須是以拍賣會當地的貨幣為單位。拍賣官將在參考**底價**後，合理地履行書面競投務求以可能的最低價行使書面標。如果您以書面競投一件沒有**底價**的**拍賣品**，而且沒有其他更高叫價，我們會為您以**低價**的 50% 進行競投；或如果您的書面標比上述更低，則以您的書面標的價格進行競投。如佳士得收到多個競投價相等的書面競投，而在拍賣時此等競投價乃該**拍賣品**之最高出價，則該**拍賣品**售給最先達達其書面競投書給本公司之競投人。

C. 拍賣之時

1. 進入拍賣現場

我們有權不允許任何人進入拍賣場地，參與拍賣，亦可拒絕接受任何競投。

2. 底價

除非另外列明，所有**拍賣品**均有**底價**。不定有**底價**的**拍賣品**，在**拍賣品**號碼旁邊用標記。**底價**不會高於**拍賣品**的**低價**估價。

3. 拍賣官之酌情權

- 拍賣官可以酌情選擇：
- 拒絕接受任何競投；
 - 以其決定方式將競投提前或拖後，或改變**拍賣品**的順序；
 - 撤回任何**拍賣品**；
 - 將任何**拍賣品**分開拍賣或將兩件或多件**拍賣品**合併拍賣；
 - 重開或繼續競投，即便已經下槌；
 - 如果有出錯或爭議，無論是在拍賣時或拍賣後，選擇繼續拍賣、決定誰是成功競投人、取消**拍賣品**的拍賣或將**拍賣品**重新拍賣或出售。在拍賣之時或後對競投有任何爭議，拍賣官有最終決定權。

4. 競投

- 拍賣官接受以下競投：
- 拍賣會場參與競投的競投人；
 - 從電話競投人，通過 Christie's Live™（如第 B6 部分所示）透過網絡競投的競投人；
 - 拍賣之前提交佳士得的書面競投（也稱為不在場競投或委託競投）。

5. 代表賣方競投

拍賣官可選擇代表賣方競投的方式連續競投或以回應其他競投者的投標而競投的方式，直至達到**底價**以下。拍賣官不會特別指明此乃代表賣方的競投。拍賣官不會代表賣方作出相等或高於**底價**之出價。就不設**底價**的**拍賣品**，拍賣官通常會以**低價**的 50% 開始拍賣。如果在此價位沒有人競投，拍賣官可以自行斟酌將價格下降繼續拍賣，直至有人競投，然後從該價位上拍賣。如果無人競投該**拍賣品**，拍賣官可視該**拍賣品**為流拍**拍賣品**。

6. 競投價遞增幅度

競投通常從低於**低價**估計開始，然後逐步增加（競投價遞增

幅度)。拍賣官會自行決定競投開始價位及遞增幅度。本目錄內的書面競投表格上顯示的是一般遞增幅度，僅供閣下參考。

7. 貨幣兌換

拍賣會的顯示板，Christie's Live™ 和佳士得網站，可能會以拍賣場地貨幣外的主要貨幣來展示競投。任何佳士得使用的兌換率僅作指引，佳士得並不受其約束。對於在提供該服務出現的任何錯誤（人為或其它），遺漏或故障，佳士得並不負責。

8. 成功競投

除非拍賣官決定使用以上 C3 段中的酌情權，拍賣官下槌即表示對最終競投價之接受。這代表賣方和成功競投人之間的買賣合約之訂立。我們僅向已登記的成功競投人開具發票。拍賣後我們會以郵寄及/或電子郵件方式發送發票，但我們並不負責通知閣下競投是否成功。如果您以書面競投，拍賣後您應儘快以電話聯繫我們或親臨本公司查詢競投結果，以避免產生不必要的倉儲費用。

9. 競投地法律

當您在我們的拍賣中競投時，您同意您會嚴格遵守所有在拍賣時生效並適用於相關拍賣場所的當地法律及法規。

D. 買方酬金及稅款

1. 買方酬金

成功競投人除支付**成交價**外，亦同意支付本公司以該**拍賣品成交價**計算的**買方酬金**。酬金率按每件**拍賣品成交價**首港幣 1,200,000 元之 25%；加逾港幣 1,200,000 元以上至港幣 20,000,000 元部分之 20%；加逾港幣 20,000,000 元以上之 12% 計算。名酒的**買方酬金**是按每件**拍賣品成交價**之 22.5%。

2. 稅費

成功競投者將負責所有適用**拍賣品**稅費，包括增值稅，銷售或補償使用稅費或者所有基於**成交價**和**買方酬金**而產生的該等稅費。買方有責任查明並支付所有應付稅費。在任何情況下香港法律先次適用。佳士得建議您徵詢獨立稅務意見。有關佳士得運送至美國的**拍賣品**，不論買方國籍或公民身份，均可須預先支付基於**成交價**，**買方酬金**和運費而產生的州銷售稅或使用稅費。佳士得現時須將其運送至紐約州的**拍賣品**收取銷售稅。適用銷售稅率由**拍賣品**將運送到的州分，縣，地點而定。要求豁免銷售稅的成功競投人必須在提取**拍賣品**之前向佳士得提供適當文件。佳士得不須收取競投者的州分，成功競投人可能須繳付稅費予該州分的稅務機構。佳士得建議您徵詢獨立稅務意見。

E. 保證

1. 賣方保證

對於每件**拍賣品**，賣方保證其：

- 為**拍賣品**的所有人，或**拍賣品**的共有人之一並獲得其他共有人的許可；或者，如果賣方不是**拍賣品**的所有人或共有人之一，其已獲得所有人的授權出售**拍賣品**或其任法律上有權這麼做；
- 有權利將**拍賣品**的所有權轉讓給買方，且該權利不負擔任何限制或任何其他人的索賠責任。

如果以上任何**保證**不確實，賣方不必支付超過您已向我們支付的**購買款項**（詳見以下第 F1(a) 段定義）的金額。賣方不會就閣下利潤上或經營的損失、預期存款、商機喪失或利息的損失、成本、賠償金、**其他賠償**或支出承擔責任。賣方不就任何**拍賣品**提供任何以上列舉之外的**保證**；只要法律許可，所有賣方對您做出**保證**及法律要求加入本協議的所有其它賣方責任均被免除。

2. 真品保證

在不抵觸以下條款的情況下，本公司保證我們拍賣的**拍賣品**都是**真品**（我們的“**真品保證**”）。如果在拍賣日後的五年內，您使我們滿意您的**拍賣品**不是**真品**，在符合以下條款規定之下，我們將把您支付的**購買款項**退還給您。業務規定的詞彙表裏有對“**真品**”一詞做出解釋。**真品保證**條款如下：

- 我們在拍賣日後的 5 年內提供**真品保證**。此期限過後，我們不再提供**真品保證**。
- 我們只會對本目錄描述第一行（“**標題**”）以大階字體注明資料作出**真品保證**。除了**標題**中顯示的資料，我們不對任何**標題**以外的資料（包括**標題**以外的大階字體注明）作出任何**保證**。
- 真品保證**不適用於有**保留標題**或有**保留**的部分**標題**。有**保留**是指受限於**拍賣品目錄**描述內的解釋，或者**標題**中有“重要通告及目錄編列方法之說明”內有**保留標題**的某些字眼。例如：**標題**中對“認為是...之作品”的使用指佳士得認為**拍賣品**可能是某位藝術家的作品，但是佳士得不**保證**該作品一定是該藝術家的作品。在競投前，請閱華“**有保留標題**”列表及**拍賣品**的**目錄**描述。
- 真品保證**適用於被**拍賣會通告**修訂後的**標題**。
- 真品保證**不適用於在拍賣之後，學術發展導致被普遍接受

的學者或專家意見有所改變。此保證亦不適用於在拍賣日時，**標題**字合被普遍接受的學者或專家的意見，或**標題**指出意見衝突的地方。

- 如果**拍賣品**只有通過科學鑒定方法才能鑒定出不是**真品**，而在我們出版目錄之日，該科學方法還未存在或未被普遍接受，或價格太昂貴或不實際，或者可能損壞**拍賣品**，則**真品保證**不適用。
- 真品保證**僅適用於**拍賣品**在拍賣時由佳士得發出之發票之原本**買方**，且僅在原本買方在拍賣日與申索之日持續擁有該**拍賣品**才適用。保證中的利益不可以轉讓。
- 要申索**真品保證**下的權利，您必須：
 - 在拍賣日後 5 年內，向我們提供書面的申索通知並提供詳情，包括完整的佐證證據；
 - 佳士得有權要求您提供為佳士得及您均事先同意的在此**拍賣品**領域被認可的兩位專家的書面意見，確認該**拍賣品**不是**真品**。如果您有任何疑問，我們保留自己支付費用獲取更多意見的權利；及
 - 自費交回與拍賣時**狀況**相同的**拍賣品**給佳士得拍賣場。
- 您在本**真品保證**下唯一的權利就是取消該項拍賣及取回已付的**購買款項**。在任何情況下我們不須支付您超過您已向我們支付的**購買款項**的金額，同時我們也無須對任何利潤或經營損失、商機或價值喪失、預期存款或利息、成本、賠償金或**其他賠償**或支出承擔責任。
- 書籍**。如果**拍賣品**為書籍，我們提供額外自拍賣日起為期 14 天的**保證**，如經校對後，**拍賣品**的文本或圖樣存有瑕疵；以下條款規限下，我們將退回已付的**購買款項**：
 - 此類外**保證**不適用於：
 - 缺少空白頁、扉頁、保護頁、廣告、及書籍鑄邊的破損、污漬、邊緣磨損或其它不影響文本及圖樣完整性的瑕疵；
 - 繪圖、簽名、書信或手稿；帶有簽名的照片、音樂唱片、地圖冊、地圖或期刊；
 - 沒有標題的書籍；
 - 沒有標明**估價**的已售**拍賣品**；
 - 目錄中表明售出後不可退貨的書籍；
 - 狀況**報告中或拍賣時公告的瑕疵。
 - 要根據本條規定申索權利，您必須在拍賣後的 14 天內就有關瑕疵提交書面通知，並交回與拍賣時**狀況**相同的**拍賣品**給當時進行拍賣的佳士得拍賣行。
- 東南亞現代及當代藝術以及中國書畫。**真品保證**並不適用於此類別**拍賣品**。目前學術界不容許對此類別作出確實之說明，但佳士得同意取消被證實為贗品之東南亞現代及當代藝術以及中國書畫**拍賣品**之交易。已付之**購買款項**則根據佳士得**真品保證**的條款退還予原本買方，但買方必須在拍賣日起 12 個月內以書面通知本公司有關**拍賣品**為贗品並能按以上 E2(h)(ii) 的規定提供令佳士得滿意的證據，證實該**拍賣品**為贗品，及須按照以上 E2(h)(iii) 規定交回**拍賣品**給我們。E2(b), (c), (d), (e), (f), (g) 和 (i) 適用於此類別之申索。
- 有關名酒及烈酒的**保證**
 - 佳士得受所接受的責任所限，賣方、佳士得、其員工或代理人均無須對有關任何貨批的任何聲明的出處、來源、日期、年份、屬性、真實性或出處之正確性負責，並對任何其他錯誤說明及**拍賣品**的缺陷或損毀亦無須負責。而賣方、佳士得、其員工或代理人均不會對任何**拍賣品**作出**保證**，並在此排除任何明示或默示的**狀況**或**保證**。
 - 如果：(i) 在拍賣日期的二十一日內，佳士得觀察到買方對任何**拍賣品**的書面通知，在競投當日買方觀察到**拍賣品**的水位不足或有自然耗損或目錄中任何意見的聲明並未良好事實基礎。(2) 在收到有關通知的十四日內，佳士得擁有之**拍賣品**與競投當日的**狀況**相同。及(3) 在期後的一段合理時間內，買方令佳士得確信有關**拍賣品**如上述買方的書面通知的情況，而買方能夠在無任何保留置權及妨礙下轉讓有關**拍賣品**的擁有權，佳士得將會撤銷買賣並向買方退還買方支付有關**拍賣品**的所有款項。如出現以下情況，買方將無本條款所載之權利：
 - 該損毀已在目錄中提及；或
 - 在競投當日目錄的說明已符合學者或專家作出之一般被採納的意見，或該說明已公正地顯示有關意見會有分歧；或
 - 您只應在目錄印行前仍通常不被採納採用的科學程序之方法，或採用在競投當日是不合理地昂貴或不可行的程序之方法、或可能損毀**拍賣品**的方法，才可證實**拍賣品**當時的情況如上述買方的書面通知的情況。（請參閱耗損及酒塞的說明）；
 - 買方不可根據此條件索償高於就該**拍賣品**所支付的金額，也不得就任何其直接或間接遭受之損失、附帶損失或損壞作出索償；
 - 此項**保證**之利益不得轉讓，由**拍賣品**出售時佳士得向其發出原有提貨單之買方全權及絕對擁有，買方於出售後一直維持擁有權，買方的擁有權從來未曾中斷或被用作抵押或擔保用途。

F. 付款

1. 付款方式

- 拍賣後，您必須立即支付以下**購買款項**：
 - 成交價**；和
 - 買方酬金**；和
 - 任何關稅、有關貨物、銷售、使用、補償或服務稅項。所有款項須於拍賣後 7 個日曆天內悉數付清（“**到期付款日**”）。
- 我們只接受登記競投人付款。發票一旦開具，發票上買方的姓名不能更換，我們亦不能以不同姓名重新開具發票。即使您欲將**拍賣品**出口且需要出口許可證，您也必須立即支付以上款項。
- 在香港佳士得購買的**拍賣品**，您必須按照發票上顯示的貨幣以下列方式支付：
 - 佳士得通過“MyChristie's”網上賬戶為客人提供查看發票、付款及運送服務。您可直接登錄查詢（如您還未註冊線上賬戶，請登錄 www.christies.com/MyChristies 進行註冊）。本服務適用於大多數**拍賣品**，但仍有少數**拍賣品**的付款和運送安排不能通過網上進行。如需協助，請與售後服務部聯絡。
 - 電匯至：
香港上海匯豐銀行總行
香港中環皇后大道中 1 號
銀行編號：004
賬號：062-305438-001
賬名：Christie's Hong Kong Limited
收款銀行代號：HSBCHKHHKHKH
 - 信用卡
在符合我們的規定下，我們接受各種主要信用卡付款。本公司每次拍賣接受總數不超過港幣 1,000,000 元之現場信用卡付款，但有關係款及限制適用。以中國銀聯支付方式之支付有金額限制。如要以“持卡人不在場”(CNP)的方式支付，本公司每次拍賣接受總數不超過港幣 500,000 元之付款。CNP 付款不適用於所有佳士得拍賣場，並受某些限制。適用於信用卡付款的條款和限制可從佳士得的售後服務部獲取，詳情列於以下 (d) 段：
 - 現金
本公司每年只接受每位買方總數不超過港幣 80,000 元之現金付款（須受有關條件約束）；
 - 銀行匯票
抬頭請註明「佳士得香港有限公司」（須受有關條件約束）
 - 支票
抬頭請註明「佳士得香港有限公司」。支票必須於香港銀行承兌並以港幣支付。
 - 支付時請註明拍賣號碼、發票號碼及客戶號碼；以郵寄方式支付必須發送到：佳士得香港有限公司，售後服務部（地址：香港中環遮打道 18 號歷山大廈 22 樓）。
 - 如要瞭解更多信息，請聯繫售後服務部。電話 +852 2760 1766 或發電郵至 postsaleasia@christies.com。

2. 所有權轉移

只有我們自您處收到全額且清算**購買款項**後，您才擁有**拍賣品**及**拍賣品**的所有權，即使本公司已將**拍賣品**交給您。

3. 風險轉移

拍賣品的風險和責任自以下日期起將轉移給您（以較早者為準）：

- 買方提貨日；
 - 自拍賣日起 35 日後，如較早，則**拍賣品**根據“香港佳士得名酒倉儲與提取”頁由第三方倉庫保管之日起；除非另行協議。
- 不付款之補救辦法
 - 如果到**到期付款日**，您未能全數支付**購買款項**，我們將有權行使以下一項或多項（及執行我們在 F5 段的權利以及法律賦予我們的其它權利或補救辦法）：
 - 自**到期付款日**起，按照尚欠款項，收取高於香港金融管理局不時公布的三個月銀行同業拆息加 7% 的利息；
 - 取消交易並按照我們認為合適的條件對**拍賣品**公開重新拍賣或私下重新售賣。您必須向我們支付原來您應支付的**購買款項**與再次轉賣收益之間的差額。您也必須支付我們必須支付或可能蒙受的一切成本、費用、損失、賠償、法律費用及任何賣方酬金的差額；
 - 代不履行政任的買方支付賣方應付的拍賣淨價金額。您承認佳士得有賣方之所有權利向您提出追討；
 - 您必須承擔尚欠之**購買款項**，我們可就取回此金額而向您提出法律訴訟程序及在法律許可下向您索回之其他損失、利息、法律費用及其他費用；
 - 將我們或**佳士得集團**任何公司欠下您之款項（包括您已付給我們之任何保證金或部分付款）用以抵銷您未付之款項；
 - 我們可以選擇將您的身份及聯繫方式披露給買方；

SYMBOLS USED IN THIS CATALOGUE

The meaning of words coloured in **bold** in this section can be found at the end of the section of the catalogue headed 'Conditions of Sale - Buying at Christie's'

◦ Christie's has a direct financial interest in the **lot**. See Important Notices and Explanation of Cataloguing Practice.

△ Owned by Christie's or another **Christie's Group** company in whole or part. See Important Notices and Explanation of Cataloguing Practice.

◆ Christie's has a direct financial interest in the **lot** and has funded all or part of our interest with the help of someone else. See Important Notices and Explanation of Cataloguing Practice.

• **Lot** offered without **reserve** which will be sold to the highest bidder regardless of the pre-sale estimate in the catalogue.

~ **Lot** incorporates material from endangered species which could result in export restrictions. See Section H2(b) of the Conditions of Sale - Buying at Christie's.

Ψ **Lot** incorporates material from endangered species that is not for sale and is shown for display purposes only.

Please note that **lots** are marked as a convenience to you and we shall not be liable for any errors in, or failure to, mark a **lot**.

本目錄中使用的各類標識

本部份粗體字體詞語的涵義載於本目錄中題為“業務規定·買方須知”一章的最後一頁。

◦ 佳士得對該**拍賣品**擁有直接經濟利益。請參閱重要通知及目錄編列方法之說明。

△ 全部或部分由佳士得或其他**佳士得集團**公司持有。請參閱重要通知及目錄編列方法之說明。

◆ 佳士得對該**拍賣品**擁有直接經濟利益，佳士得的全部或部分利益通過第三方融資。請參閱重要通知及目錄編列方法之說明。

• 不設底價的**拍賣品**，不論其在本目錄中的售前估價，該**拍賣品**將售賣給出價最高的競投人。

~ **拍賣品**含有瀕危物種的材料，可能受出口限制。請參閱業務規定·買方須知第 H2(b) 段。

Ψ **拍賣品**含有瀕危物種的材料，只用作展示用途，並不作銷售。

請注意對藏品的標記僅為您提供方便，本公司不承擔任何因標示錯誤或遺漏標記的責任。

IMPORTANT NOTICES AND EXPLANATION OF CATALOGUING PRACTICE

IMPORTANT NOTICES

CHRISTIE'S INTEREST IN PROPERTY CONSIGNED FOR AUCTION

△: Property Owned in part or in full by Christie's

From time to time, Christie's may offer a lot which it owns in whole or in part. Such property is identified in the catalogue with the symbol △ next to its lot number.

◦ Minimum Price Guarantees:

On occasion, Christie's has a direct financial interest in the outcome of the sale of certain lots consigned for sale. This will usually be where it has guaranteed to the Seller that whatever the outcome of the auction, the Seller will receive a minimum sale price for the work. This is known as a minimum price guarantee. Where Christie's holds such financial interest we identify such lots with the symbol ◦ next to the lot number.

◦◆ Third Party Guarantees/Irrevocable bids

Where Christie's has provided a Minimum Price Guarantee it is at risk of making a loss, which can be significant, if the lot fails to sell. Christie's therefore sometimes chooses to share that risk with a third party. In such cases the third party agrees prior to the auction to place an irrevocable written bid on the lot. The third party is therefore committed to bidding on the lot and, even if there are no other bids, buying the lot at the level of the written bid unless there are any higher bids. In doing so, the third party takes on all or part of the risk of the lot not being sold. If the lot is not sold, the third party may incur a loss. Lots which are subject to a third party guarantee arrangement are identified in the catalogue with the symbol ◦◆.

Christie's compensates the third party in exchange for accepting this risk provided that the third party is not the successful bidder. The remuneration to the third party may either be based on a fixed fee or an amount calculated against the final hammer price. The third party may also bid for the lot above the written bid. Where the third party is the successful bidder, the third party is required to pay the hammer price and the buyer's premium in full.

Third party guarantors are required by us to disclose to anyone they are advising their financial interest in any lots they are guaranteeing. However, for the avoidance of any doubt, if you are advised by or bidding through an agent on a lot identified as being subject to a third party guarantee you should always ask your agent to confirm whether or not he or she has a financial interest in relation to the lot.

Other Arrangements

Christie's may enter into other arrangements not involving bids. These include arrangements where Christie's has given the Seller an Advance on the proceeds of sale of the lot or where Christie's has shared the risk of a guarantee with a partner without the partner being required to place an irrevocable written bid or otherwise participating in the bidding on the lot. Because such arrangements are unrelated to the bidding process they are not marked with a symbol in the catalogue.

Bidding by parties with an interest

In any case where a party has a financial interest in a lot and intends to bid on it we will make a saleroom announcement to ensure that all bidders are aware

of this. Such financial interests can include where beneficiaries of an Estate have reserved the right to bid on a lot consigned by the Estate or where a partner in a risk-sharing arrangement has reserved the right to bid on a lot and/or notified us of their intention to bid.

Please see <http://www.christies.com/financial-interest/> for a more detailed explanation of minimum price guarantees and third party financing arrangements.

Where Christie's has an ownership or financial interest in every lot in the catalogue, Christie's will not designate each lot with a symbol, but will state its interest in the front of the catalogue.

FOR PICTURES, DRAWINGS, PRINTS AND MINIATURES, SCULPTURES, INSTALLATION, VIDEO, CALLIGRAPHY AND PAINTED CERAMIC

Terms used in this catalogue have the meanings ascribed to them below. Please note that all statements in this catalogue as to authorship are made subject to the provisions of the Conditions of Sale and authenticity warranty. Buyers are advised to inspect the property themselves. Written condition reports are usually available on request.

QUALIFIED HEADINGS

In Christie's opinion a work by the artist.

**Attributed to ..."

In Christie's qualified opinion probably a work by the artist in whole or in part.

**Studio of ..."/ "Workshop of ..."

In Christie's qualified opinion a work executed in the studio or workshop of the artist, possibly under his supervision.

“Circle of ...”
In Christie’s qualified opinion a work of the period of the artist and showing his influence.
**Follower of ...”
In Christie’s qualified opinion a work executed in the artist’s style but not necessarily by a pupil.
**Manner of ...”
In Christie’s qualified opinion a work executed in the artist’s style but of a later date.
**After ...”
In Christie’s qualified opinion a copy (of any date) of a work of the artist.
**Signed ...”/“Dated ...”/
“Inscribed ...”
In Christie’s qualified opinion the work has been signed/dated/inscribed by the artist.
**With signature ...”/“With date ...”/
“With inscription ...”
In Christie’s qualified opinion the signature/date/inscription appears to be by a hand other than that of the artist.

The date given for Old Master, Modern and Contemporary Prints is the date (or approximate date when prefixed with ‘circa’) on which the matrix was worked and not

necessarily the date when the impression was printed or published.

*This term and its definition in this Explanation of Cataloguing Practice are a qualified statement as to authorship. While the use of this term is based upon careful study and represents the opinion of specialists, Christie’s and the consignor assume no risk, liability and responsibility for the authenticity of authorship of any lot in this catalogue described by this term, and the Authenticity Warranty shall not be available with respect to lots described using this term.

OPTIONS TO BUY PARCELS

A parcel consists of several lots of the same wine of identical lot size, bottle size and description. Bidding will start on the first lot of the parcel and the successful buyer of that lot is entitled to take some or all of the remaining lots in the parcel at the same hammer price. If the buyer of the first lot does not take further lots, the remaining lots of the parcel will be offered in a similar fashion. We recommend that a bid on a parcel lot be placed on the first lot of the parcel. If the bid is superseded, Christie’s will automatically move your bid to the next identical lot and so on. In all

instances, such bids will be handled at the auctioneer’s discretion.

CLASSIFICATIONS

Bordeaux Classifications in the text are for identification purposes only and are based on the official 1855 classification of the Médoc and other standard sources. All wines are Château-bottled unless stated otherwise.

ULLAGES AND CORKS OF OLD WINES

Wines are described in this catalogue as correctly as can be ascertained at time of going to press, but buyers of old wines must make appropriate allowances for natural variations of ullages, conditions of cases, labels, corks and wine. No returns will be accepted.

ULLAGE

The amount by which the level of wine is short of being full: these levels may vary according to age of the wines and, as far as can be ascertained by inspection prior to the sale, are described in the catalogue. A chart explaining level and ullage descriptions and interpretations, together with a visual presentation, appears in this catalogue. We hope you will find this helpful.

重要通知及目錄編列方法之說明

重要通告

佳士得在受委託拍賣品中的權益

▲: 部分或全部歸佳士得擁有的拍賣品

佳士得可能會不時提供佳士得集團旗下公司全部或部分擁有之拍賣品。該等拍賣品在目錄中於拍賣編號旁註有 ▲ 符號以資識別。

◦ 保證最低出售價

佳士得有時就某些受委託出售的拍賣品的拍賣成果持有直接的經濟利益。通常為其向賣方保證無論拍賣的結果如何，賣方將就拍賣品的出售獲得最低出售價。這被稱為保證最低出售價。該等拍賣品在目錄中於拍賣編號旁註有 ◦ 符號以資識別。

◦ ◆ 第三方保證 / 不可撤銷的競投

在佳士得已經提供最低出售價保證，如果拍賣品未能出售，佳士得將承擔遭受重大損失的風險。因此，佳士得有時選擇與第三方分擔該風險。在這種情況下，第三方同意在拍賣之前該拍賣品提交一份不可撤銷的書面競投。第三方因此承諾競投該拍賣品，如果沒有其它競投，等三方將以書面競投價格購買該拍賣品，除非有其它更高的競價。第三方因此承擔拍賣品未能出售的所有或部分風險。如果拍賣品未能出售，第三方可能承擔損失。該等拍賣品在目錄中註以符號 ◦ ◆ 以資識別。

第三方需要承擔風險，在自身不是成功競投人的情況下，佳士得將給予酬金給第三方。第三方的酬金可以是固定金額或基於成交價計算的酬金。第三方亦可以就該拍賣品以超過書面競投的價格進行競投。如果第三方成功競投，第三方必須全額支付成交價及買方酬金。

我們要求第三方保證人向其客戶披露在給予保證的拍賣品持有的經濟利益。如果您通過顧問意見或委託代理人競投一件標示為有第三方融資的拍賣品，我們建議您應當要求您的代理人確認他 / 她是否在拍賣品持有經濟利益。

其他安排

佳士得可能訂立與競投無關的協議。這些協議包括佳士得向賣方就拍賣品銷售所得預付金額或者佳士得與第三方分擔保證風險，但並不要求第三方提供不可撤銷的書面競投或參與拍賣品的競投。因為上述協議與競投過程無關，我們不會在目錄中註以符號。

利益方的競投

如果競投人在拍賣品持有經濟利益並欲競投該拍賣品，我們將以拍賣場通知的方式知會所有競投者。該經濟利益可包括遺產受益人保留權利參與競投，遺產委託拍賣的拍賣品或者風險共擔安排下的合作方保留權利參與競投拍賣品和 / 或通知我們其競投該拍賣品的意願。

請登錄 <http://www.christies.com/financial-interest/> 瞭解更多關於最低出售價保證以及第三方融資安排的說明。

如果佳士得在目錄中每一項拍賣品中均有所有權或經濟利益，佳士得將不會於每一項拍賣品旁附註符號，但會於正文首頁聲明其權益。

有關繪畫、素描、版畫、小型畫、雕塑、裝置、錄像、書法及手繪瓷器

下列詞語於本目錄中具有以下意義。請注意本目錄中有關作者身份的所有聲明均按照本公司之業務規定及真品保證的條款而作出。

買方應親自檢視各拍賣品的狀況，亦可向佳士得要求提供書面狀況報告。

有保留的標頭

佳士得認是屬於該藝術家之作品

* 「傳」、「認為是...之作品」

指以佳士得有保留之意見認為，某作品大概全部或部份是藝術家之創作。

* 「...之創作室」及「...之工作室」

指以佳士得有保留之意見認為，某作品在某藝術家之創作室或工作室完成，可能在他監督下完成。

* 「...時期」

指以佳士得有保留之意見認為，某作品屬於該藝術家時期之創作，並且反映出該藝術家之影響。

* 「跟隨...風格」

指以佳士得有保留之意見認為，某作品具有某藝術家之風格，但未必是該藝術家門生之作品。

* 「具有...創作手法」

指以佳士得有保留之意見認為，某作品具有某藝術家之風格，但於較後時期完成。

* 「...複製品」

指以佳士得有保留之意見認為，某作品是某藝術家作品之複製品（任何日期）。

* 「簽名...」、「日期...」、「題寫...」

指以佳士得有保留之意見認為，某作品由某藝術家簽名 / 寫上日期 / 題詞。

* 「附有...簽名」、「附有...之日期」、「附有...之題詞」、「款」

指以佳士得有保留之意見認為某簽名 / 某日期 / 題詞應不是某藝術家所為。

古代、近現代印刷品之日期是指製造作品之日期 [或大概日期] 而不一定是作品印刷或出版之日。

* 於本目錄編列方法之說明中此詞語及其定義為對作者身份而言之有規限說明。雖然本詞語之使用，乃基於審慎研究及代表專家之意見，佳士得及委託人於目錄內使用此詞語及其所描述之拍賣品及其作者身份之真確及可信性，並不承擔及接受任何風險、義務或責任，而真品保證條款，亦不適用於以此詞語所描述的拍賣品。

購買一系列貨批的選擇權

一組貨批內含多批相同批量、瓶容量及種類的名酒。競投將會由一系列貨批之中的第一貨批開始，成功競投的買家有權以相同的成交價購入系列中部分或全部貨批。若果第一貨批的買家未有進一步購入，該系列貨批的餘下貨批將會相似的方式開放競投。佳士得建議對貨批的出價應在該系列貨批的第一貨批之上。如果出價被取代，佳士得將會自動把買家的出價置在下一相同貨批，如此類推。在所有情況下，有關出價均全權由拍賣官處理。

分類

內容中的波爾多分類標準僅作識別之用，並且根據 Médoc 1855 年正式的分類標準及其他標準來源。除註明外，所有名酒均在莊園內裝瓶。

舊酒的自然耗損及酒塞

在本目錄內列明的名酒均在印刷前確定內容正確，惟舊酒買家必須對自然程度的耗損、酒箱狀況、標籤、酒塞及名酒的差異作出包容。恕不接受退貨。

耗損

名酒水位未能達至滿的水位之差距，有關差距會根據名酒之年期而有所不同，而在銷售前能通過檢驗確定的，均會在目錄中註明。本目錄以圖表的形式詳細說明水位與損耗量形容及解釋以方便閣下參考。

LEVEL/ULLAGE DESCRIPTIONS AND INTERPRETATIONS

(see notes below)

BORDEAUX

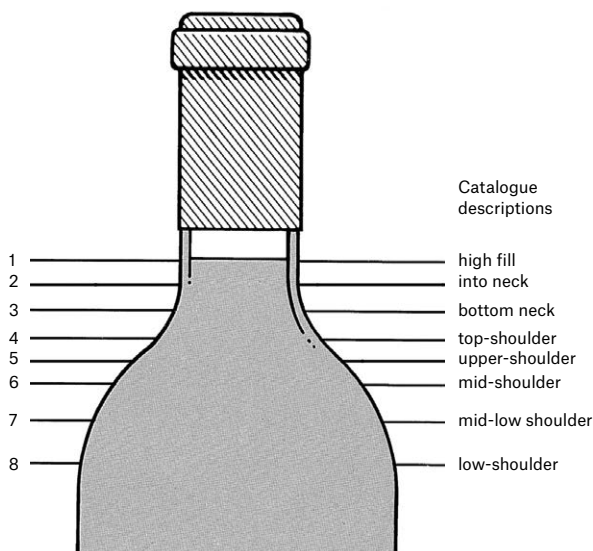

BURGUNDY

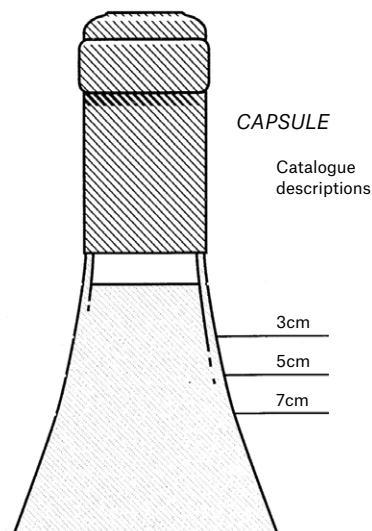

- 1 into neck: Level of young wines. Exceptionally good in wines over 10 years old.
- 2 bottom neck: Perfectly good for any age of wine. Outstandingly good for a wine of 20 years in bottle, or longer.
- 3 very top-shoulder
- 4 top-shoulder: Normal for any claret 15 years old or older.
- 5 upper-shoulder: Slight natural reduction through the easing of the cork and evaporation through cork and capsule. Usually no problem. Acceptable for any wine over 20 years old. Exceptional for pre-1950 wines.

- 6 mid-shoulder: Probably some weakening of the cork and some risk. Not abnormal for wines 30/40 years of age. Estimates usually take this into account.
- 7 mid-low-shoulder: Some risk. Low estimates.
- 8 low-shoulder: Risky and usually only accepted for sale if wine or label exceptionally rare or interesting. Always offered with low estimate.

Because of the slope of shoulder it is impractical to describe levels as mid-shoulder, etc. Wherever appropriate the level between cork and wine will be measured and catalogued in centimetres.

The condition and drinkability of burgundy is less affected by ullage than its equivalent from Bordeaux. For example, a 5 to 7 cm. ullage in a 30-year-old burgundy can be considered normal, indeed good for age, 3.5 to 4 cm. excellent for age, even 7cm. rarely a risk.

BOTTLE SIZES

- magnum = two regular bottles (1.5L)
- marie-jeanne = three regular bottles (2.5L)
- double-magnum = four regular bottles (3L)
- jeroboam = four regular bottles (3L)
(Burgundy, Champagne)
- jeroboam = six regular bottles (5L)
(Bordeaux)
- impériale = eight regular bottles (6L)
(Bordeaux)
- methuselah = eight regular bottles (6L)
(Burgundy)
- balthazar = sixteen regular bottles (12L)
- nebuchadnezzar = twenty regular bottles (15L)
- melchior = twenty-four regular bottles (18L)

SPECIAL NOTICE

Though every effort is made to describe or measure the levels of older vintages, corks over 20 years old begin to lose their elasticity and levels can change between cataloguing and sale. Old corks have also been known to fail during or after shipment. **We therefore repeat that there is always a risk of cork failure with old wines and due allowance must be made for this. Under no circumstances can an adjustment of price or credit be made after delivery except under the terms stated in Paragraph I of the Conditions of Sale - Buying at Christie's. Unless otherwise stated, Bordeaux are château bottled and all wines are bottled in the country of production.**

Important note regarding opening of cases and listing of levels: Christie's general policy is to open all wood cases and to describe levels. Bidders must make allowances for reasonable variations in ullage which may be encountered in cases older than twenty years. Additionally, all wine younger than twenty years have levels bottom neck or better unless otherwise noted.

狀況 / 損耗量形容及解釋

(請細閱以下)

波爾多

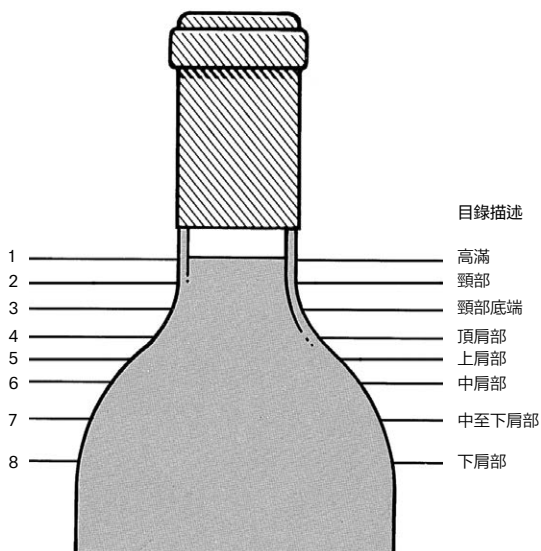

- 1 頸部：
新酒的正常水位。若酒齡超過 10 年的酒還保持這水位，是非常好的。
- 2 頸部底端：
對任何酒齡的酒來說，都是很好的，尤其是如酒齡是超過 20 年的酒。
- 3 最頂肩部
- 4 頂肩部：
正常的如酒齡是 15 年或以上。
- 5 上肩部：
因酒塞鬆懈及蒸發以至有少許自然的退減，一般是沒有問題的。可接受如酒齡超過 20 年。

勃根地

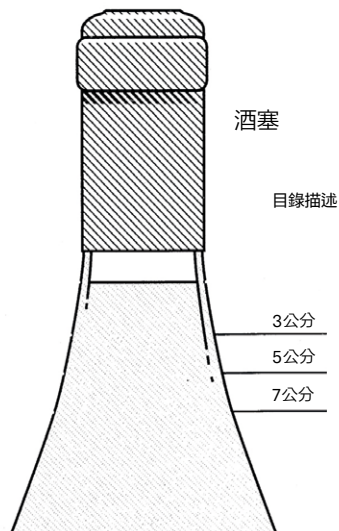

- 6 中肩部：
酒塞可能有一些削弱，有一些風險，不是異常的如酒齡到達 30/40 年。估值通常會把此計算在內。
- 7 中至低肩部：
有些風險，低估值。
- 8 低肩部：
高風險及一般只會售賣當酒或招紙是很稀有或珍貴。常常也是低估值。

由於肩部的斜度並不能夠形容中肩等的水位，在可能的情況下酒塞及名酒之間的距離將會以厘米量度及收錄。
勃根地酒的狀況及可飲用程度，較之於波爾多酒，較少受自然耗損影響。例如酒齡為三十年的勃根地酒有 5 至 7 厘米的自然耗損可視為正常。酒齡良好的，會有 3.5 至 4 厘米的自然耗損，酒齡超卓的甚至會有 7 厘米的自然耗損，很少具有風險。

酒瓶大小

magnum	= 2 個標準瓶 (1.5 公升)
marie-jeanne	= 3 個標準瓶 (2.5 公升)
double-magnum	= 4 個標準瓶 (3 公升)
jeroboam (Burgundy, Champagne)	= 4 個標準瓶 (3 公升)
jeroboam (Bordeaux)	= 6 個標準瓶 (5 公升) (或 5 升)
impériale (Bordeaux)	= 8 個標準瓶 (6 公升)
methuselah (Burgundy)	= 8 個標準瓶 (6 公升)
balthazar	= 16 個標準瓶 (12 公升)
nebuchadnezzar	= 20 個標準瓶 (15 公升)
melchior	= 24 個標準瓶 (18 公升)

特別通告

儘管已盡一切辦法去形容或量度較舊名酒的水位，超過 20 年的酒塞亦會開始失去其彈性，水位可能在收錄目錄及銷售期間改變。舊酒塞亦已知可能在運送或運抵後失效。佳士得因此重申舊酒的酒塞經常有損壞的風險，必須對此有適當的寬容。除出現在業務規定·買方須知第 1 段的情況，在任何情況下，在運送後均不可調整價格或退款。除註明外，所有波爾多酒均於莊園裝瓶，所有名酒均在生產國裝瓶。

有關打開酒箱及列明水位的重要註釋：佳士得一般的政策是打開所有木酒箱，並說明水位。按標者必須對酒齡 20 年及以上的名酒可能出現的自然耗損的合理差異有所寬容。此外，除另有註明，所有酒齡 20 年以下的名酒均有頸部底端或更佳的水位。

WORLDWIDE SALEROOMS AND OFFICES AND SERVICES

**ARGENTINA
BUENOS AIRES**
+54 11 43 93 42 22
Cristina Carlisle

**AUSTRALIA
SYDNEY**
+61 (0)2 9326 1422
Ronan Sulich

**AUSTRIA
VIENNA**
+43 (0)1 533 881214
Angela Baillou

**BELGIUM
BRUSSELS**
+32 (0)2 512 88 30
Roland de Lathuy

**BERMUDA
BERMUDA**
+1 401 849 9222
Betsy Ray

**BRAZIL
SÃO PAULO**
+5511 3061 2576
Nathalie Lenci

**CHILE
SANTIAGO**
+56 2 2 2631642
Denise Ratnoff
de Lira

**COLOMBIA
BOGOTÁ**
+571 635 54 00
Juanita Madrinan

**DENMARK
COPENHAGEN**
+45 3962 2377
Birgitta Hillingsø
(Consultant)
+ 45 2612 0092
Rikke Juel Brandt
(Consultant)

**FINLAND AND
THE BALTIC STATES
HELSINKI**
+358 40 5837945
Barbro Schauman
(Consultant)

**FRANCE
BRITTANY AND
THE LOIRE VALLEY**
+33 (0)6 09 44 90 78
Virginie Greggory
(Consultant)

**GREATER
EASTERN FRANCE**
+33 (0)6 07 16 34 25
Jean-Louis Janin Daviet
(Consultant)

NORD-PAS DE CALAIS
+33 (0)6 09 63 21 02
Jean-Louis Brémilts
(Consultant)

•PARIS
+33 (0)1 40 76 85 85

**POITOU-CHARENTE
AQUITAINE**
+33 (0)5 56 81 65 47
Marie-Cécile Moueix

**PROVENCE -
ALPES CÔTE D'AZUR**
+33 (0)6 71 99 97 67
Fabienne Albertini-
Cohen

RHÔNE ALPES
+33 (0)6 61 81 82 53
Dominique Pierron
(Consultant)

**GERMANY
DÜSSELDORF**
+49 (0)21 14 91 59 352
Arno Verkade

FRANKFURT
+49 (0)173 317 3975
Anja Schaller
(Consultant)

HAMBURG
+49 (0)40 27 94 073
Christiane Gräfin
zu Rantzau

MUNICH
+49 (0)89 24 20 96 80
Marie Christine Gräfin
Huyn

STUTTGART
+49 (0)71 12 26 96 99
Eva Susanne
Schweizer

**INDIA
•MUMBAI**
+91 (22) 2280 7905
Sonal Singh

**INDONESIA
JAKARTA**
+62 (0)21 7278 6268
Charmie Hamami

**ISRAEL
TEL AVIV**
+972 (0)3 695 0695
Roni Gilat-Baharaff

**ITALY
•MILAN**
+39 02 303 2831

ROME
+39 06 686 3333
Marina Cicogna

NORTH ITALY
+39 348 3131 021
Paola Gradi
(Consultant)

TURIN
+39 347 2211 541
Chiara Massimello
(Consultant)

VENICE
+39 041 277 0086
Bianca Arrivabene
Valenti Gonzaga
(Consultant)

BOLOGNA
+39 051 265 154
Benedetta Possati Vittori
Venenti (Consultant)

GENOA
+39 010 245 3747
Rachele Guicciardi
(Consultant)

FLORENCE
+39 055 219 012
Alessandra Niccolini di
Camugliano (Consultant)

**CENTRAL &
SOUTHERN ITALY**
+39 348 520 2974
Alessandra Allaria
(Consultant)

**JAPAN
TOKYO**
+81 (0)3 6267 1766
Chie Banta

**MALAYSIA
KUALA LUMPUR**
+65 3 6735 1766
Nicole Tee

**MEXICO
MEXICO CITY**
+52 55 5281 5546
Gabriela Lobo

MONACO
+377 97 97 11 00
Nancy Dotta

**THE NETHERLANDS
•AMSTERDAM**
+31 (0)20 57 55 255

**NORWAY
OSLO**
+47 975 800 78
Katinka Traaseth
(Consultant)

**PEOPLES REPUBLIC
OF CHINA
BEIJING**
+86 (0)10 8583 1766

•HONG KONG
+852 2760 1766

•SHANGHAI
+86 (0)21 6355 1766

**PORTUGAL
LISBON**
+351 919 317 233
Mafalda Pereira Coutinho
(Consultant)

**RUSSIA
MOSCOW**
+7 495 937 6364
+44 20 7389 2318
Katya Vinokurova

**SINGAPORE
SINGAPORE**
+65 6735 1766
Nicole Tee

**SOUTH AFRICA
CAPE TOWN**
+27 (21) 761 2676
Juliet Lomborg
(Independent
Consultant)

**DURBAN &
JOHANNESBURG**
+27 (31) 207 8247
Gillian Scott-Berning
(Independent
Consultant)

WESTERN CAPE
+27 (44) 533 5178
Annabelle Conyngham
(Independent
Consultant)

**SOUTH KOREA
SEOUL**
+82 2 720 5266
Jun Lee

**SPAIN
MADRID**
+34 (0)91 532 6626
Juan Varez
Dalia Padilla

**SWEDEN
STOCKHOLM**
+46 (0)73 645 2891
Claire Ahman
(Consultant)
+46 (0)70 9369 201
Louise Dyhlén
(Consultant)

**SWITZERLAND
•GENEVA**
+41 (0)22 319 1766
Eveline de Proyart

•ZÜRICH
+41 (0)44 268 1010
Dr. Bertold Mueller

**TAIWAN
TAIPEI**
+886 2 2736 3356
Ada Ong

**THAILAND
BANGKOK**
+66 (0)2 652 1097
Satima Tanabe

**TURKEY
ISTANBUL**
+90 (532) 558 7514
Eda Kehale Argün
(Consultant)

**UNITED ARAB
EMIRATES
•DUBAI**
+971 (0)4 425 5647

**UNITED KINGDOM
•LONDON,
KING STREET**
+44 (0)20 7839 9060

**NORTH AND
NORTHEAST**
+44 (0)20 3219 6010
Thomas Scott

**NORTHWEST
AND WALES**
+44 (0)20 7752 3033
Jane Blood

SOUTH
+44 (0)1730 814 300
Mark Wrey

SCOTLAND
+44 (0)131 225 4756
Bernard Williams
Robert Lagneau
David Bowes-Lyon
(Consultant)

ISLE OF MAN
+44 (0)20 7389 2032

CHANNEL ISLANDS
+44 (0)20 7389 2032

IRELAND
+353 (0)87 638 0996
Christine Ryall
(Consultant)

**UNITED STATES
CHICAGO**
+1 312 787 2765
Lisa Cavanaugh

DALLAS
+1 214 599 0735
Caperia Ryan

HOUSTON
+1 713 802 0191
Jessica Phifer

LOS ANGELES
+1 310 385 2600

MIAMI
+1 305 445 1487
Jessica Katz

NEWPORT
+1 401 849 9222
Betsy D. Ray

•NEW YORK
+1 212 636 2000

SAN FRANCISCO
+1 415 982 0982
Ellanor Notides

AUCTION AND OTHER SERVICES PRIVATE SALES

HK: +852 2978 6871
Fax: +852 2760 1767
Email: privatesaleservicecentre@christies.com

CHRISTIE'S EDUCATION

New York
Tel: +1 212 355 1501
Fax: +1 212 355 7370
Email: newyork@christies.edu

Hong Kong
Tel: +852 2978 6768
Fax: +852 2525 3856
Email: hongkong@christies.edu

London
Tel: +44 (0)20 7665 4350
Fax: +44 (0)20 7665 4351
Email: london@christies.edu

CHRISTIE'S INTERNATIONAL REAL ESTATE

New York
Tel: +1 212 468 7182
Fax: +1 212 468 7141
Email: info@christiesrealestate.com

London
Tel: +44 (0)20 7389 2551
Fax: +44 (0)20 7389 2168
Email: info@christiesrealestate.com

Hong Kong
Tel: +852 2978 6788
Fax: +852 2760 1767
Email: info@christiesrealestate.com

CHRISTIE'S FINE ART STORAGE SERVICES

New York
Tel: +1 212 974 4579
Email: newyork@cfass.com

Singapore
Tel: +65 6543 5252
Email: singapore@cfass.com

• DENOTES SALEROOM

ENQUIRIES — Call the Saleroom or Office
For a complete salerooms & offices listing go to christies.com

EMAIL — info@christies.com

CHRISTIE'S HONG KONG WINE STORAGE AND COLLECTION

All wines offered for auction in this catalogue are lying in Christie's appointed cellar, Crown Wine Cellars.

Buyers wishing to collect from the storage facility directly may do so by prior arrangement. Crown Wine Cellars will only release the lots upon your signature of a Christie's Collection Order. Request for deliveries can be made after receipt of cleared funds and must be at least 2 business days prior to date of delivery. All shipping charges, local delivery charges, transit insurance and packing will be at the expense of the buyers. All charges will have to be prepaid to Christie's before shipment can be effected. All breakages or missing bottles must be reported to Christie's within three days of collection or delivery of the wine lots. To arrange the pick-up or delivery of your purchase, please contact Mr. Kelvin Pun or Ms. Angel Lam of Crown Wine Cellars at +852 2453 3530.

If lots are not collected within thirty-five calendar days following the sale, Crown Wine Cellars Limited will charge you and you will have to pay all storage charges incurred from the thirty-sixth calendar day following the sale for the period while the lot(s) are stored at Crown Wine Cellars Limited's storage facility. Crown Wine Cellars Limited will invoice the buyers directly. Buyers agree that Christie's will provide the buyers' contact details to Crown Wine Cellars Limited for the purposes of invoicing and collection of storage fees.

Local Delivery Charges for normal orders (All prices are subject to change)

Urgent, express orders and other areas not mentioned below will be quoted separately.

Delivery/Collection			
Bottle	Hong Kong Island	Kowloon & New Territories	Lantau Island & Ma Wan
1-6	HKD300	HKD210	HKD330
7-12	HKD350	HKD260	HKD380
13-48	HKD450	HKD360	HKD480
49-240	HKD620	HKD530	HKD650

* For 241 bottles and above, please contact Crown Wine Cellars at Tel: +852 2453 3530.

** Delivery Charges include insurance.

Delivery Schedule: Monday to Friday 11:00-17:00
Saturday before 12:00

The storage facility information is listed below:

Storage Facility (Tuen Mun)

Contact: Mr. Kelvin Pun (kpun@crownww.com)
Ms. Angel Lam (angellam@crownww.com)
Tel: +852 2453 3530
Address: 2/F, Crown Data Centre 1,
6 Kin Fung Circuit, Tuen Mun, N.T.

Office Hours: Monday to Friday 10:00-12:30 and 14:00-17:30
Saturday 10:00-12:30

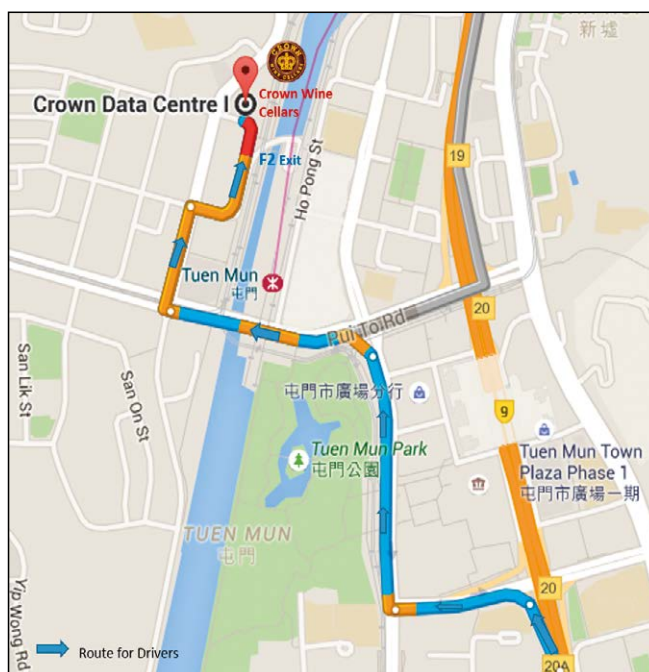

Overseas Delivery

For designated countries, Christie's will be pleased to assist with making arrangements for the packing, shipping and transit insurance of the purchased lots at the buyer's request and expense upon receipt of all outstanding payment in cleared funds. Christie's will obtain quotes at the buyer's request. All shipping charges have to be agreed and pre-paid before shipment can be effected. Christie's charges a 10% administrative fee on the shipping quote for managing your shipment. Please be reminded that all shipping quotes are exclusive of any tax and/or duties imposed by government authorities. It is the Buyer's sole responsibility to obtain any required export or import licenses.

Please contact our Post-Sale Services Department +852 2760 1766 or postsaleasia@christies.com for further information.

香港佳士得名酒倉儲與提取

所有在此拍賣的名酒現儲存於佳士得委任的酒窖 - Crown Wine Cellars Limited。

買家如欲直接從儲存設施提貨，請作提前通知以作安排。買家需要簽署由佳士得發出的提貨通知單，以便 Crown Wine Cellars Limited 發放拍賣品。買家支付所有費用後可提出貨品付運的要求，但有關要求必需於付運日期前的兩個工作天提出。買家須負責提取或安排本地送遞及／或運送。所有運費、本地送遞、運輸保險及包裝的費用將由買家負責。所有費用要在運送前預先繳付予佳士得，才會進行付運。所有破損或遺漏瓶數，必須在收到拍賣品後的三天內向佳士得報告。有關安排運送及提取事宜，請聯絡 Crown Wine Cellars Limited 潘先生或林小姐，電話為 +852 2453 3530。

如果已購買的名酒在拍賣日後三十五個日曆天內仍未提取，即表示授權 Crown Wine Cellars Limited 儲存該名酒，有關儲存費用會由買家支付，直至該名酒被提取為止。Crown Wine Cellars Limited 將會向買家收取儲存費用並直接向買家發出發票。買家同意佳士得向 Crown Wine Cellars Limited 提供買家之資料，作為發出發票和收取儲存費之用途。

本地普通運單付運費用（價格或有更改）

加急運單及其他不在運輸範圍內區域的運單，請向佳士得名酒部查詢。

送貨 / 收貨			
數量	香港島	九龍及新界	大嶼山及馬灣
1-6 瓶	港幣 300	港幣 210	港幣 330
7-12 瓶	港幣 350	港幣 260	港幣 380
13-48 瓶	港幣 450	港幣 360	港幣 480
49-240 瓶	港幣 620	港幣 530	港幣 650

* 241 瓶及以上，請向 Crown Wine Cellars 查詢 +852 2453 3530。

** 送貨收費包括保險費。

送貨時間：星期一至五 上午十一時至下午五時
星期六 正午十二時前

有關儲存設施資料列舉如下：

儲存設施（屯門）

聯絡人：潘先生（kpun@crownww.com）
林小姐（angellam@crownww.com）
辦公室電話：+852 2453 3530
地址：新界屯門建豐街 6 號
嘉柏中心 1 期 2 樓

酒窖辦公時間：星期一至五 上午十時正至下午十二時三十分及
下午二時正至下午五時三十分
星期六 上午十時正至下午十二時三十分

海外付運

若付運到其他指定國家，在買方以清算現金全數付清所有欠款後，佳士得可依照買家之要求，代為安排包裝、付運及運輸保險事宜，買家須繳付有關收費。佳士得會根據買家要求，提供報價給買家。所有付運須於買家同意該運費及繳付後方作安排。佳士得會收取付運報價的 10% 以作行政費用。請注意所有付運報價不包括任何稅項及 / 或出入口稅項。買家須負責取得所有相關的進出口牌照。

詳情請向香港佳士得售後服務部 +852 2760 1766 或 postsaleasia@christies.com 查詢。

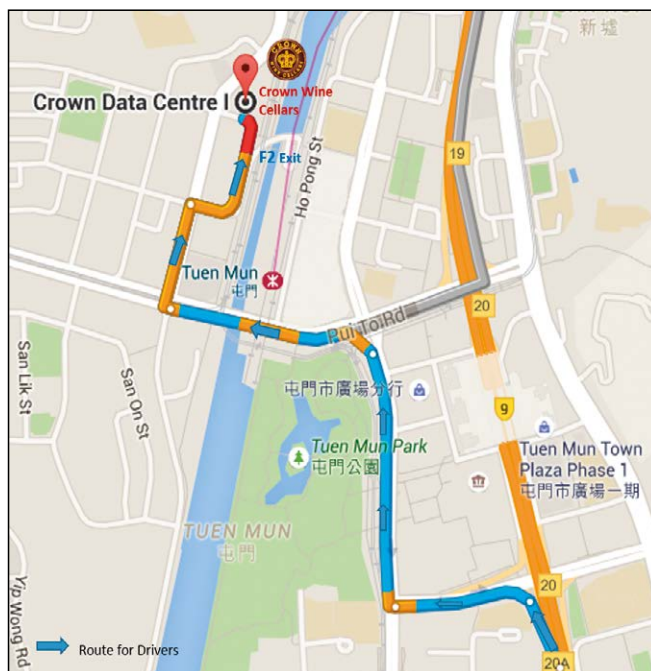

**FINE AND RARE WINES:
MELINA & NK YONG'S CELLAR**
**FINE AND RARE WINES: ESTEEMED
CONNOISSEUR MR YAP CHEE MENG'S
PRIVATE COLLECTION PART II**

FRIDAY 8 SEPTEMBER 2017 AT 5.00 PM (LOTS 1-267)
SATURDAY 9 SEPTEMBER 2017 AT 11.00 AM
(LOTS 268-870)

The James Christie Room,
22nd Floor, Alexandra House,
18 Chater Road, Central, Hong Kong

CODE NAME: SING
SALE NUMBER: 14719
LOT NUMBER: 1-870

Please note that Christie's does not accept payment from third parties, including agents, and that invoice details cannot be changed after the sale.

**BID ONLINE FOR THIS SALE AT
WWW.CHRIESTIES.COM**

BIDDING INCREMENTS

Bidding generally starts below the **low estimate** and increases in steps (bid increments) of up to 10 per cent. The auctioneer will decide where the bidding should start and the bid increments. Written bids that do not conform to the increments set below may be lowered to the next bidding-interval.

HK\$1,000 to HK\$2,000
HK\$2,000 to HK\$3,000
HK\$3,000 to HK\$5,000

by HK\$100s
by HK\$200s
by HK\$200, 500, 800
(ie: HK\$4,200, HK\$4,500,
HK\$4,800)

HK\$5,000 to HK\$10,000
HK\$10,000 to HK\$20,000
HK\$20,000 to HK\$30,000
HK\$30,000 to HK\$50,000

by HK\$500s
by HK\$1,000s
by HK\$2,000s
by HK\$2,000, 5,000, 8,000
(ie: HK\$32,000, HK\$35,000,
HK\$38,000)

HK\$50,000 to HK\$100,000
HK\$100,000 to HK\$200,000
HK\$200,000 to HK\$300,000
HK\$300,000 to HK\$500,000

by HK\$5,000s
by HK\$10,000s
by HK\$20,000s
by HK\$20,000, 50,000, 80,000
(ie: HK\$320,000, HK\$350,000,
HK\$380,000)

HK\$500,000 to HK\$1,000,000
Above HK\$1,000,000

by HK\$50,000s
at auctioneer's discretion

The auctioneer may vary the increments during the course of the auction at his or her own discretion.

- I request Christie's to bid on the stated **lots** up to the maximum bid I have indicated for each **lot**.
- I understand that if my bid is successful the amount payable will be the sum of the **hammer price** and the **buyer's premium (together with any taxes chargeable on the hammer price and buyer's premium in accordance with the Conditions of Sale - Buying at Christie's)**. The **buyer's premium** rate shall be an amount equal to 25% of the **hammer price** of each **lot** up to and including HK\$ 1,200,000, 20% on any amount over HK\$ 1,200,000 up to and including HK\$ 20,000,000 and 12% of the amount above HK\$ 20,000,000. For wine there is a flat rate of 22.5% of the **hammer price** of each **lot** sold.
- I agree to be bound by the Conditions of Sale - Buying at Christie's printed in the catalogue.
- I understand that if Christie's receive written bids on a **lot** for identical amounts and at the auction these are the highest bids on the lot, Christie's will sell the **lot** to the bidder whose written bid it received and accepted first.
- Written bids submitted on "no **reserve**" **lots** will, in the absence of a higher bid, be executed at approximately 50% of the **low estimate** or at the amount of the bid if it is less than 50% of the **low estimate**.

I understand that Christie's written bid service is a free service provided for clients and that, while Christie's will be as careful as it reasonably can be, Christie's will not be liable for any problems with this service or loss or damage arising from circumstances beyond Christie's reasonable control.

Auction Results: +852 2760 1766

The auctioneer will usually only accept bids for High Value Lots if a deposit has been arranged prior to the day of sale and the High Value Lot pre-registration application has been completed. High Value Lot Deposit Forms should be sent to the Bids Department by email to bidsasia@christies.com. I understand that if I have not completed the High Value Lot pre-registration before sale I will not be permitted to bid for High Value Lots.

If you are not successful in any bid and do not owe any Christie's group company any money, the deposit will be refunded to you by way of wire transfer or such other method as determined by Christie's. Please make sure that you provide your bank details in the High Value Lot Deposit Forms.

Written Bids Form

Christie's Hong Kong

Written bids must be received at least 24 hours before the auction begins. Christie's will confirm all bids received by e-mail by return e-mail. If you have not received confirmation within one business day, please resubmit your bid(s) or contact: Bid Department. Tel: +852 2978 9910 Email: bidsasia@christies.com.

Client Number (if applicable)

Client Name (please print)

Address

Post Code

Contact Number (Mobile)

(Fax)

Email

Please tick if you do not want to receive your invoice by email.

Please tick if you prefer not to receive information about our upcoming sales by e-mail

I HAVE READ AND UNDERSTOOD THIS WRITTEN BID FORM AND THE CONDITIONS OF SALE - BUYING AT CHRISTIE'S

Signature

Date

If you have not previously bid or consigned with Christie's, please attach copies of the following documents. **Individuals:** government-issued photo identification (such as a photo driving licence, national identity card, or passport) and, if not shown on the ID document, proof of current address, for example a utility bill or bank statement. **Corporate clients:** certificate of incorporation, proof of company address, photo ID copy of the authorized bidder, letter of authorization duly signed by the director or the legal representative and, where applicable, chopped with company stamp and official document listing directors and shareholders. **Other business structures such as trusts, offshore companies or partnerships:** please contact the Credit Department at + 852 2978 6870 for advice on the information you should supply. If you are registering to bid on behalf of someone who has not previously bid or consigned with Christie's, please attach identification documents for yourself as well as the party on whose behalf you are bidding, together with a signed letter of authorisation from that party.

New clients, clients who have not made a purchase from any Christie's office within the last 12 months, and those wishing to spend more than on previous occasions will be asked to supply a bank reference and/or a recent bank statement and we may also require a deposit as we deem appropriate as a condition of allowing you to bid. If you are asked to provide a deposit, you will need to arrange payment with us. Your bidder registration will not be considered complete until we receive payment of the deposit in full and cleared funds.

PLEASE PRINT CLEARLY

Lot number (in numerical order)	Number of Lots required	Maximum Bid HK\$ (excluding buyer's premium)



佳士得名釀

二〇一七年 九月八日
星期五 下午五時正
(拍賣品編號 1-267)

二〇一七年 九月九日
星期六 上午十一時正
(拍賣品編號 268-870)

香港中環遮打道 18 號歷山大廈 22 樓
佳士得藝廊

編號名稱：**SING**
拍賣編號：**14719**
拍賣品編號：**1-870**

佳士得不接受包括代理人在內之第三方支付款；付款資料於拍賣會完結後將不能更改。

參與網絡競投可登入佳士得網站 www.christies.com

競投價遞增幅度

競投一般由低於**低端估價**開始，通常每次減價之遞增幅度（競投價遞增幅度）最高為 10%，拍賣官會自行決定競投開始價位及遞增幅度。書面競投價若與下列之遞增幅度不一致，將被調低至下一個減價金額：

競投價	每次減價之遞增金額
1,000-2,000 港元	100 港元
2,000-3,000 港元	200 港元
3,000-5,000 港元	200, 500, 800 港元 (例 4,200, 4,500, 4,800 港元)
5,000-10,000 港元	500 港元
10,000-20,000 港元	1,000 港元
20,000-30,000 港元	2,000 港元
30,000-50,000 港元	2,000, 5,000, 8,000 港元 (例 32,000, 35,000, 38,000 港元)
50,000-100,000 港元	5,000 港元
100,000-200,000 港元	10,000 港元
200,000-300,000 港元	20,000 港元
300,000-500,000 港元	20,000, 50,000, 80,000 港元 (例 320,000, 350,000, 380,000 港元)
500,000-1,000,000 港元	50,000 港元
1,000,000 港元或以上	拍賣官自行決定

在拍賣時拍賣官可酌情更改每次增加之額度。

- 茲請求佳士得就本表格所列的**拍賣品**進行競投，直至本表格所列的最高出價。
- 本人知悉如競投成功，本人應付之購買款項為**成交價及買方酬金（以及所有基於成交價和買方酬金而產生的稅費，及符合業務規定之買方須知）**。**買方酬金**費率按每件**拍賣品**成交價首港幣 1,200,000 元之 25%，加逾港幣 1,200,000 元以上至 20,000,000 元部份之 20%；加逾港幣 20,000,000 元以上之 12% 計算。名釀的**買方酬金**是按每件**拍賣品**成交價之 22.5%。
- 本人同意接受本目錄中所列之業務規定的管限。
- 本人理解如佳士得收到多個競投價相等的書面競投，而在拍賣時此等競投價乃該**拍賣品**之最高出價，則該**拍賣品**售給最先送達其書面競投書給本公司之競投人。
- 如果您以書面競投一件“沒有底價”的**拍賣品**，而且沒有其他更高叫價，我們會為您以**低端估價**的 50% 進行競投；或如果您的投標價低於**低端估價**的 50%，則以您的投標價進行競投。

本人亦明白，佳士得的書面競投服務為一項向客戶提供的免費服務，佳士得會合理謹慎進行，佳士得不就任何在佳士得控制的範圍以外產生的損失或賠償負責。

拍賣結果查詢：+852 2760 1766

拍賣官一般僅接受已於拍賣日前繳付保證金並已完成高額拍賣品預先登記人士之高額拍賣品競投。請將已填妥之高額拍賣品之登記表格電郵 bidsasia@christies.com 至投標部。本人知悉若本人未於拍賣前完成高額拍賣預先登記，本人將不獲准競投高額拍賣品。

若閣下未能成功競投任何**拍賣品**，對佳士得或佳士得集團其他公司亦無任何欠款，保證金將以電匯方式或佳士得決定之其他方式退還閣下。請確保閣下已提供有關之銀行資料詳情。

書面競投表格

香港佳士得

書面競投必須在拍賣開始前至少 24 小時收到。

佳士得公司將以電郵確認收到閣下電郵之書面競投表格。如您在一個工作日內未能收到確認，請重新遞交書面競投表格或聯繫投標部。

電話：+852 2978 9910 電郵：bidsasia@christies.com

客戶編號（若適用）

客戶名稱（請用正楷填寫）

地址

郵編

聯絡電話（手提電話）

傳真

電郵

如閣下選擇不以電郵方式收取發票，請於方格內劃上「✓」號。

如閣下不希望透過電郵接收本公司將舉行的拍賣、活動或其他由佳士得集團及其聯營公司提供的服務資料，請於方格內劃上「✓」號。

我本人已細閱並理解本書面競投表格及業務規定，買方須知。

簽名

日期

如閣下未曾於佳士得競投或託售**拍賣品**，請附上以下文件之副本。**個人**：政府發出附有相片的身分證明文件（如國民身分證或護照），及（如身分證文件未有顯示現時住址）現時住址證明，如公用事業帳單或銀行月結單。**公司客戶**：公司註冊證書、公司地址證明、被授權競投者附有相片的身分證明文件，由公司董事或法人按公司規定簽署及（若有）蓋有公司章的競投授權書，以及列出所有董事及股東的公司文件。**其他業務結構，如信託機構、離岸公司或合夥公司**：請與信用部聯絡，以諮詢閣下須提供何種資料，電話為 +852 2978 6870。如閣下登記代表未曾於佳士得競投或託售**拍賣品**人士競投，請附上閣下本人的身分證明文件，以及閣下所代表競投人士的身分證明文件，連同該人士簽署的授權書。

新客戶、過去十二個月內未有在佳士得投得**拍賣品**，及本次擬出價金額高於過往之客戶，須提供銀行信用證明及／或近期的銀行月結單，亦或須繳付本公司指定的有關保證金作為允許閣下競投的先決條件。如閣下被要求提供保證金，閣下需與我們聯繫以安排付款。閣下的競投申請會在我們收到保證金的全額付款後方可作實。

請用正楷填寫清楚

拍賣品編號 (按數字排序)	拍賣品數量	最高競投價 (港幣) (買方酬金不計在內)



BIDDER REGISTRATION FORM

Paddle No. _____

We encourage new clients to register at least 48 hours in advance of a sale to allow sufficient time to process the registration.

Please complete and sign this form and send it to us by email registrationasia@christies.com.

A Bidder's Detail

The name and address given above will appear on the invoice for lots purchased with your assigned paddle for this registration. Please check that the details are correct as the invoice cannot be changed after the sale.

Account No.

Account Name

Address

City/District Post/Zip Code

County/State Country

Phone No.

Email

Invoice will be sent by email. Please tick if you do NOT wish to receive your invoice by email.

Shipping quote required.

Shipping Address (same as the above address)

B Sale Registration

Please register me for the following sessions:

14719 Fine and Rare Wines

14709 The Pavilion Sale - Chinese Ceramics and Works of Art

C Identity Documents and Financial References

If you have not previously bid or consigned with Christie's, please provide copies of the following documents. **Individuals:** government-issued photo identification (such as a national identity card or passport) and, if not shown on the ID document, proof of current address, for example a utility bill or bank statement. **Corporate clients:** a certificate of incorporation, proof of company address, photo ID copy of the authorized bidder, letter of authorization duly signed by the director or the legal representative and, where applicable, chopped with company stamp and official document listing directors and shareholders. **Other business structures such as trusts, offshore companies or partnerships:** please contact the Credit Department at +852 2978 6870 for advice on the information you should supply. If you are registering to bid on behalf of someone who has not previously bid or consigned with Christie's, please attach identification documents for yourself as well as the person on whose behalf you are bidding, together with a signed letter of authorisation from the person. New clients, clients who have not made a purchase from any Christie's office within the last 12 months, and those wishing to spend more than on previous occasions will be asked to supply a bank reference and/or a recent bank statement and we may also require a deposit as we deem appropriate as a condition of allowing you to bid. If you are asked to provide a deposit, you will need to arrange payment with us. Your bidder registration will not be considered complete until we receive payment of the deposit in full and cleared funds.

High Value Lots Paddle Registration:

Do you require a High Value Lot ("HVL") paddle? Yes No

You will need a HVL paddle if you intend to bid on: (i) any lot in the Asian 20th Century & Contemporary Art Evening Sale; or (ii) a lot the low estimate of which is HK\$ 8 million or above. The auctioneer will only take bids on High Value Lots from bidders holding HVL paddles. To secure your HVL paddle, you will need to pay a HVL deposit, which we will calculate for you. Generally it will be the higher of: (i) HK\$ 1,500,000 or (ii) 20 % of the aggregate low estimates of the HVLs you intend to bid on; or (iii) such other amount as we may determine from time to time. You can pay your HVL deposit using any of the following methods: credit card(s) acceptable to Christie's; wire transfer; cashier order or cheque. We cannot accept payment from third parties and agents. The HVL registration procedure applies even if you have already registered to bid in our sales on other lots. Please allow at least 48 hours for processing of your HVL registration. We reserve the right to change our HVL registration procedure and requirements from time to time without notice.

Please indicate the bidding level you require:

HK \$ 0 - 500,000

HK \$ 500,001 - 2,000,000

HK \$ 2,000,001 - 4,000,000

HK \$ 4,000,001 - 8,000,000

HK \$ 8,000,001 - 20,000,000

HK \$ 20,000,000 +

D Declarations

- I have read the "Conditions of Sale - Buying at Christie's" and "Important Notices and Explanation of Cataloguing Practice" printed in the sale catalogue, as well as the "No Third Party Payment Notice" and agree to be bound by them.
- I have read the data collection section of the conditions of sale printed in the sale catalogue and agree to be bound by its terms.
- The auctioneer will usually only accept bids for high value lots if a deposit has been arranged before the day of the auction and the high value lot pre-registration application has been completed. I understand that if I have not completed the high value lot pre-registration before the auction I will not be permitted to bid for high value lots.
- If you are not successful in any bid and do not owe any Christie's group company any money, the deposit will be refunded to you by way of wire transfer or such other method as determined by Christie's. please make sure that you provide your bank details to us.

Please tick if you are a new client and would like to receive information about sales, events and other services offered by the Christie's group and its affiliates by e-mail. You can opt-out of receiving this information at any time.

Name Signature Date

Christie's Hong Kong Limited

22nd Floor Alexandra House, 18 Chater Road, Central, Hong Kong Tel: +852 2760 1766

www.christies.com



建議新客戶於拍賣舉行前至少 48 小時辦理登記，以便有充足時間處理登記手續。

請填妥並簽署本表格然後電郵至 registrationasia@christies.com。

A 投標者資料

客戶名稱及地址會列印在附有是次登記之競投牌編號的發票上；付款資料於拍賣會完結後將不能更改，請確定以上資料確實無誤

客戶編號

客戶名稱

客戶地址

城市 / 區 郵區編號

縣 / 省 / 州 國家

電話號碼

電郵地址

如閣下選擇不以電郵方式收取發票，請於方格內劃上「✓」號。

請提供運費報價。

運送地址 (同上述地址相同)

B 拍賣項目登記

本人有意競投下列拍賣項目：

14719 佳士得名釀

14709 古今 | 佳士得

C 身份證明文件及財務證明

如閣下未曾於佳士得競投或託售拍賣品，請提供以下文件之副本。**個人**：政府發出附有相片的身分證明文件（如國民身份證或護照），及（如身分證明文件未有顯示現時住址）現時住址證明，如公用事業帳單或銀行月結單。**公司客戶**：公司註冊證書、公司地址證明、被授權競投者附有相片的身分證明文件，由公司董事或法人按公司規定簽署及（若有）蓋有公司章的競投授權書，以及列出所有董事及股東的公司文件。**其他業務結構，如信託機構、離岸公司或合夥公司**：請與信用部聯絡，以諮詢閣下須提供何種資料，電話為 +852 2978 6870。如閣下登記代表未曾於佳士得競投或託售拍賣品人士競投，請附上閣下本人的身分證明文件，以及閣下所代表競投人士的身分證明文件，連同該人士簽署的授權書。新客戶、過去十二個月內未有在佳士得投得拍賣品，及本次擬出價金額高於過往之客戶，須提供銀行信用證明及／或近期的銀行月結單，亦或須繳付本公司指定的有關保證金作為允許閣下競投的先決條件。如閣下被要求提供保證金，閣下需與我們聯繫以安排付款。閣下的競投申請會在我們收到保證金的全額付款後方可作實。

高價拍賣品競投牌登記：

閣下是否需要高價拍賣品競投號碼牌？ 是 否

如閣下有意競投 (i) 佳士得亞洲二十世紀及當代藝術晚間拍賣之任何拍賣品；或 (ii) 其他類別拍賣低估價為港幣 8,000,000 元或以上的拍賣品，必須預先登記領取高價拍賣品競投號碼牌。對於高價拍賣品拍賣官只會接受持有高價拍賣品競投號碼牌的競投者出價。閣下需繳付保證金以領取高價拍賣品競投號碼牌。保證金一般為 (i) 港幣 1,500,000 元；或 (ii) 閣下擬競投的全部拍賣品低估價總額之 20%；或 (iii) 其他我們不時設定的金額（以較高者為準）。閣下可以佳士得接受之信用卡、電匯、本票或支票繳付保證金。請注意佳士得不接受第三方或代理人代付之款項。即使閣下已於佳士得其他拍賣登記，閣下仍需為高價拍賣品按高價拍賣品登記程序進行登記。請於拍賣舉行前至少 48 小時辦理登記，以確保有充足時間處理閣下的高價拍賣品登記手續。佳士得保留不時更改高價拍賣品登記程序及要求的權利而不作另行通知。

請提供閣下之競投總額：

港幣 0 - 500,000

港幣 500,001 - 2,000,000

港幣 2,000,001 - 4,000,000

港幣 4,000,001 - 8,000,000

港幣 8,000,001 - 20,000,000

港幣 20,000,000 +

D 聲明

• 本人已細閱載於目錄內之業務規定、買家須知、重要通告及目錄編列方法之說明及不接受第三方付款通告，並同意遵守所有規定。

• 本人已細閱載於目錄內業務規定之資料搜集條款，並同意遵守該規定。

• 拍賣官僅接受已於拍賣日前繳付保證金並已完成高價拍賣品預先登記人士之高價拍賣品競投。本人知悉若本人未於拍賣前完成高價拍賣預先登記，本人將不獲准競投高價拍賣品。

• 若閣下未能成功競投任何拍賣品，對佳士得或佳士得公司集團亦無任何欠款，保證金將以電匯方式或佳士得決定之其他方式退還閣下。請確保閣下已提供有關之銀行資料詳情。

如閣下為新客戶並希望透過電郵接收本公司將舉行的拍賣、活動或其他由佳士得集團及其聯營公司提供的服務資料，請於方格內劃上「✓」號。閣下可隨時選擇拒收此訊息。

姓名 簽署 日期



CHRISTIE'S

CHRISTIE'S INTERNATIONAL PLC

François Pinault, Chairman
Patricia Barbizet, Deputy Chairwoman
Guillaume Cerutti, Chief Executive Officer
Jussi Pylkkänen, Global President
Stephen Brooks, Deputy Chief Executive Officer
François Curiel, Chairman, Europe & Asia
Loïc Brivezac, Gilles Erulin, Gilles Pagniez,
Héloïse Temple-Boyer
Sophie Carter, Company Secretary

INTERNATIONAL CHAIRMEN

Stephen Lash, Chairman, Emeritus, Americas
The Earl of Snowdon, Honorary Chairman, EMERI
Charles Cator, Deputy Chairman, Christie's Int.
Xin Li, Deputy Chairwoman, Christie's Int.

CHRISTIE'S ASIA

François Curiel, Chairman
Rebecca Wei, President

CHAIRMAN'S OFFICE

Jonathan Stone, Chairman, Asian Art
Jinqing Cai, Chairwoman, China
Eric Chang, Deputy Chairman
Ben Clark, Deputy Chairman
Ben Kong, Deputy Chairman
Vickie Sek, Deputy Chairwoman

CHRISTIE'S ADVISORY BOARD, ASIA

Rebecca Wei, Chairwoman
Raymond Ch'ien, Pierre Chen,
The Baroness Dunn, William Fung,
Anthony Lin, Dee Poon, Mimi Tang,
Robert Tsao, Douglas Woo

CHRISTIE'S ADVISORY BOARD, CHINA

Jinqing Cai, Chairwoman
Qionger Jiang, Pan Gong Kai, Handel Lee,
Mary Ma, Patrick Thomas, Wang Wei

SENIOR VICE PRESIDENTS

Pola Antebi, Karen Au Yeung, Chie Banta,
Lavina Chan, YF Cheung, Elaine Holt,
Mary Lee, Kitty Mak, Ada Ong,
Julien Pradels, Audrey Shum, Simon Tam,
Chi Fan Tsang, Katsura Yamaguchi

VICE PRESIDENTS

Carmen Shek Cerne, Joyce Chan, Janet Chang,
Blanca Cheng, Fung Chiang, Jennie Chu,
Charmie Hamami, Gloria Ho, Julia Hu,
Marcello Kwan, Elaine Kwok, Stephenie Leung,
Ruben Lien, Gabrielle Mak, Sara Mao,
Lillian Ng, Jasmin Ngai, Gen Ogo,
Jessie Or, Terence Poon, Alexandra Reid,
Bo Tan, Francis Tsang, Lihua Tung,
Han-I Wang, Nicole Wright, Alan Yip,
Kim Yu

ASSOCIATE VICE PRESIDENTS

Hami Bianchi, Jeff Chan, Selina Chan,
Lesley Chen, Liang-Lin Chen, Amy Cheng,
Isaac Choi, Terry Choi, Yanie Choi,
Betsy Chow, Dai Dai, Helen Fung,
Phybie Ho, Dexter How, Yunah Jung,
Bigol Lam, Kevyn Leung, Nelly Li,
Rachel Li, May Lim, Georgina Liu,
Yu-Shan Lu, Benson Or, Felix Pei,
Othniel Jai Prakash, Mandy Wang, Michael Xie,
Maxwell Yao, Dina Zhang, Michelle Zhang,
Grace Zhuang

28/07/17





CHRISTIE'S 佳士得

22ND FLOOR ALEXANDRA HOUSE 18 CHATER ROAD CENTRAL HONG KONG
香港 中環 遮打道18號 歷山大廈22樓